		<b>DATA SHEET</b> of <b>AC INDUCTION MOTOR</b>				<b>120 HP - 8 P</b> <b>TE</b>			
		DESIGN NO : <b>KS C4202-1996</b>							
Model No.or RFQ No.		Item No.		Rev. No.		[ 0 ]			
Project Name		Project No.		Quantity :					
GENERAL SPECIFICATION				PERFORMANCE DATA					
Frame No.		280L		Output		120 HP 90 KW			
Type		TNB		Poles		8 P			
Enclosure(Protection)		Totally Enclosed (IP IP54 )		Rotor Type		Squirrel Cage			
Cooling Method		IC411(FC)		Starting Method(*)		<input checked="" type="checkbox"/> D.O.L. <input type="checkbox"/> Y-Δ			
Frequency		60 Hz		Rated Voltage		440 V      380 V      220 V			
Phase		3 φ		Current		Rated Load			
Insulation Class		<input checked="" type="checkbox"/> F <input type="checkbox"/> B <input type="checkbox"/> H				Start'g-D.O.L.		151.2 A      175.0 A      302.3 A 876.8 A      1,015.2 A      1,753.6 A	
Temp. Rise at full load (by resistance method)				Efficiency					
at 1.0 S.F		105 °C		50% Load		92.1 %			
Location		<input type="checkbox"/> Indoor <input type="checkbox"/> Outdoor		75% Load		93.0 %			
Altitude		Less than 1000 meter		100% Load		93.0 %			
Humidity		Less than 80 %		Power Factor					
Ambient Temp.		40 °C (Max.)		50% Load		75.0 %			
Duty		CONT.(S1)		75% Load		80.0 %			
Service Factor		1.00		100% Load		84.0 %			
Electric Design		NEMA Design B		Speed at Rated Load		880 RPM / SLIP 2.22 %			
Construction		<input type="checkbox"/> B3 <input type="checkbox"/> B5 <input type="checkbox"/> V1 <input type="checkbox"/>		Torque (D.O.L)					
Bearing		Type		Anti-friction		Rated			
		DE/ODE		6318C3 \ 6316C3		Starting			
		Lubricant		GREASE(ALVANIA#2)		Break down			
External Thrust		Not applicable		Allowable Load GD <sup>2</sup> referred to motor shaft					
Coupling Method		<input checked="" type="checkbox"/> Direct <input type="checkbox"/> V-Belt		819.900 Kg.m <sup>2</sup>					
Shaft Extension		<input checked="" type="checkbox"/> Single <input type="checkbox"/> Double		Motor GD <sup>2</sup>					
Terminal Box		Main		<input type="checkbox"/> Steel <input checked="" type="checkbox"/> Cast Iron		Noise Level (dB(A))			
		Aux.		<input type="checkbox"/> Yes <input checked="" type="checkbox"/> No		Vibration(Velocity)			
		Location		<input checked="" type="checkbox"/> Left <input type="checkbox"/> Right (Viewed from Drive End)		Starting Duty		Cold 2 times \ Hot 1 time	
				Paint		Munsell No. 4.0PB5.4/5.5(VL-451)			
Application				SUBMITTAL DRAWING					
Area Classification		Not applicable		Outline Dimension Drawing \ Motor Weight(Approx.)					
Applicable Standard		KS		<input type="checkbox"/> B3      TJ8LAP51      860 Kg					
Inspection and Performance Test		HHI Stand.    Maker Test Report		<input type="checkbox"/> B5      TJ8LBP51      900 Kg					
				<input type="checkbox"/> V1      TJ8LPP51      900 Kg					
				Main T-Box Ass'y				3M-016882	
ACCESSORIES(OPTION ITEM)									
SPARE PARTS				REMARK					
Note: Others not mentioned in this specification shall be in accordance with HHI standard. Above technical data are only design values and shall be guaranteed with tolerance of applicable standard.				Date		DSND		CHKD	
				2004.01.27		KIM R.G.			

HHI W230-131-1 \* In case of Inverter or V.V.V.F Motor:Performance data is based on sine wave tests. A4(210mm X 297mm)



**TEFC**  
**THREE PHASE INDUCTION MOTOR**

**TYPE**

(1) TNB , TDB

CAST IRON FRAME

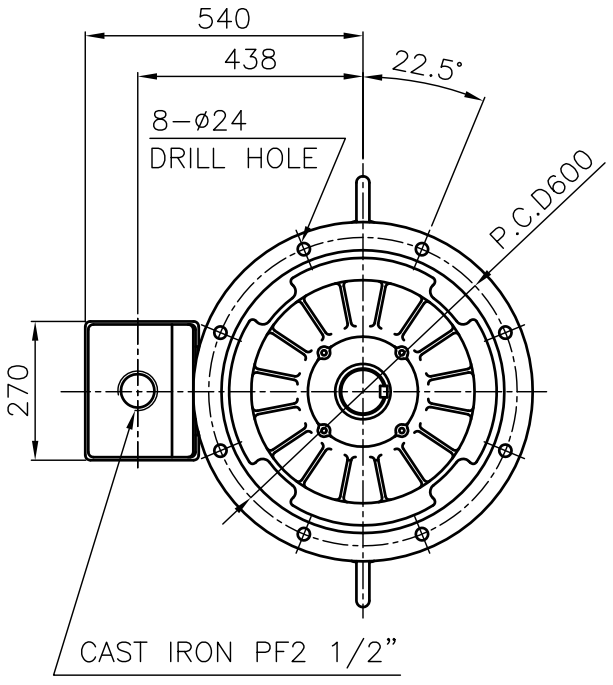
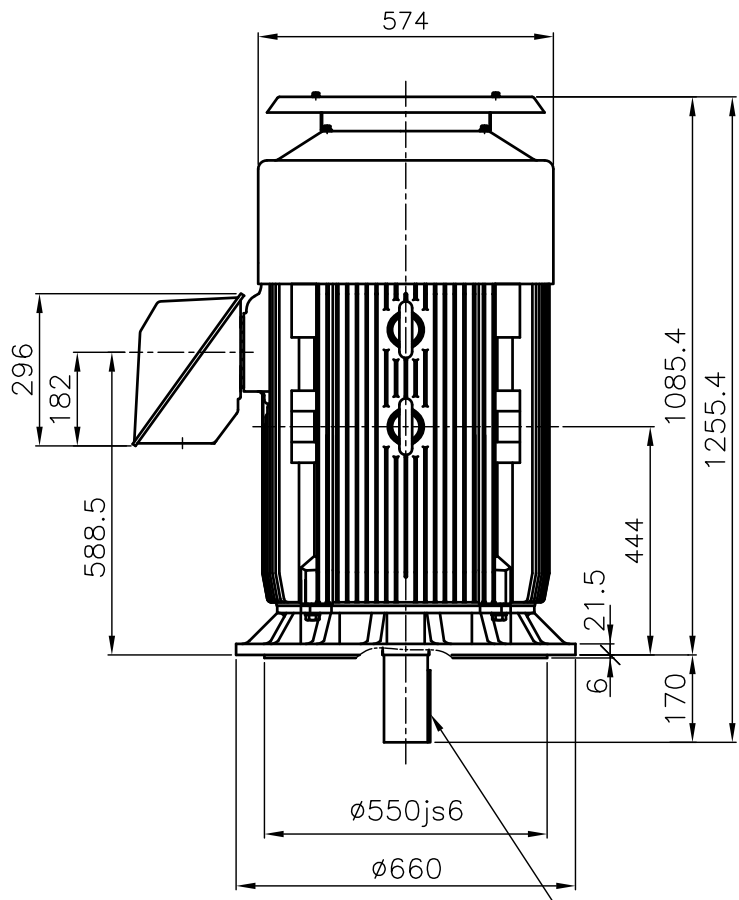

↑  
"A"

KEY 22x14x140

**NOTE**

1.TOLERANCE :

RABBET DIAMETER	ø550js6	±0.022
SHAFT DIAMETER	ø85m6	+0.035 +0.013
KEYWAY WIDTH	22P9	-0.022 -0.074
KEYWAY DEPTH	9	+0.2 0

2.The type (1)-"TNB, TDB" is for HHI's standard products and it can be changed for customer's requirements or detail designing.

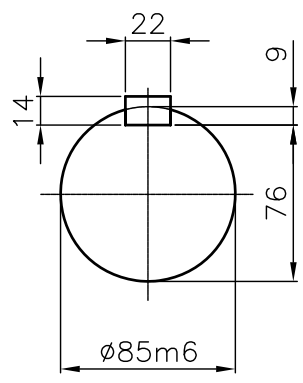

**VIEW "A"**  
SCALE 4/1

TEFC STANDARD

CAD PROJ \ FILE  
MMSTDMTR/TJ8LPP51

APPD BY	KANG K.J.	UNIT	MM
CHKD BY	KIM O.J.	SCALE	1/15
CHKD BY	LEE N.D.	PROJEC'N	3rd Angle
DSND BY	KIM RYANG GYU	DATE	2007.03.23

SUBJECT	KS Fr.280L TEFC	
TITLE	OUTLINE THREE-PHASE INDUCTION MOTOR	



REF. NO	L3-SERIES	Sheet No. of
DWG NO	TJ8LPP51	Revision No. 0



# PERFORMANCE CURVE

CURVE NO.

P-TNBJ8L08090

TYPE :		
RATED TORQUE :	99.6	Kg.m
GD2 OF MOTOR :	17.7	Kg.m <sup>2</sup>
(ALLOWABLE) GD2 OF LOA	819.9	Kg.m <sup>2</sup>

90 kW	8 P	60 Hz	
RATED SPEED : 880 RPM			
VOLTAGE	440V	380 V	220V
RATED CURRENT	151.2A	175.0 A	302.3A

SPEED VS TORQUE & CURRENT CURVE

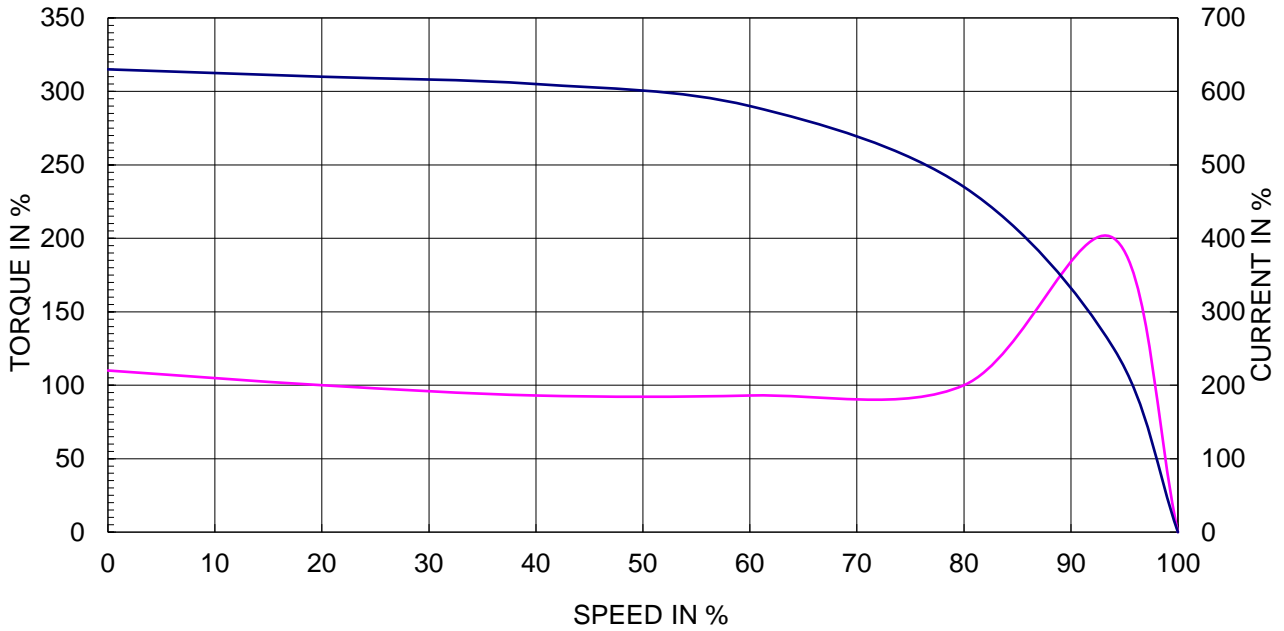

OUTPUT VS EFF., P.F & CURRENT CURVE

