		DATA SHEET of AC INDUCTION MOTOR				100 HP - 2 P TE	
						DESIGN NO : KS C4202-1996	
Model No.or RFQ No.		Item No.		Rev. No.	[0]		
Project Name		Project No.		Quantity :			
GENERAL SPECIFICATION			PERFORMANCE DATA				
Frame No.	250S		Output	100 HP 75 KW			
Type	TNB		Poles	2 P			
Enclosure(Protection)	Totally Enclosed (IP IP54)		Rotor Type	Squirrel Cage			
Cooling Method	IC411(FC)		Starting Method(*)	<input checked="" type="checkbox"/> D.O.L. <input type="checkbox"/> Y-Δ			
Frequency	60 Hz		Rated Voltage	440 V	380 V	220 V	
Phase	3 φ		Current	Rated Load	118.6 A	137.3 A	237.2 A
Insulation Class	<input checked="" type="checkbox"/> F <input type="checkbox"/> B <input type="checkbox"/> H			Start'g-D.O.L	747.1 A	865.0 A	1,494.2 A
Temp. Rise at full load (by resistance method)			Efficiency				
at 1.0 S.F			105 °C				
Location	<input type="checkbox"/> Indoor <input type="checkbox"/> Outdoor		50% Load		90.9 %		
Altitude	Less than 1000 meter		75% Load		91.5 %		
Humidity	Less than 80 %		100% Load		91.7 %		
Ambient Temp.	40 °C (Max.)		Power Factor				
Duty	CONT.(S1)		50% Load		87.5 %		
Service Factor	1.00		75% Load		90.0 %		
Electric Design	NEMA Design B		100% Load		90.5 %		
Construction	<input type="checkbox"/> B3 <input type="checkbox"/> B5 <input type="checkbox"/> V1 <input type="checkbox"/>		Speed at Rated Load		3570 RPM / SLIP 0.83 %		
Bearing	Type	Anti-friction		Torque (D.O.L)			
	DE/ODE	6313C3 \ 6313C3		Rated	20.5 Kg.m	100 %	
	Lubricant	GREASE(ALVANIA#2)		Starting	30.7 Kg.m	150 %	
External Thrust	Not applicable		Break down	47.1 Kg.m	230 %		
Coupling Method	<input checked="" type="checkbox"/> Direct <input type="checkbox"/> V-Belt		Allowable Load GD ² referred to motor shaft				
Shaft Extension	<input checked="" type="checkbox"/> Single <input type="checkbox"/> Double		31.500 Kg.m ²				
Terminal Box	Main	<input type="checkbox"/> Steel <input checked="" type="checkbox"/> Cast Iron		Motor GD ²			
	Aux.	<input type="checkbox"/> Yes <input checked="" type="checkbox"/> No		2.100 Kg.m ²			
	Location	<input checked="" type="checkbox"/> Left <input type="checkbox"/> Right (Viewed from Drive End)		Noise Level (dB(A))			
			93 dB(A) at 1m from motor(No-load)		Vibration(Velocity)		
			3.8 mm/sec.(peak)		Starting Duty		
			Cold 2 times \ Hot 1 time		Paint		
			Munsell No.		4.0PB5.4/5.5(VL-451)		
Application			SUBMITTAL DRAWING				
Area Classification			Not applicable				
Applicable Standard			KS				
Inspection and Performance Test			Outline Dimension Drawing \ Motor Weight(Approx.)				
HHI Stand. Maker Test Report			<input type="checkbox"/> B3 TJ5SAC50 450 Kg		<input type="checkbox"/> B5 TJ50BC50 470 Kg		
ACCESSORIES(OPTION ITEM)			<input type="checkbox"/> V1 TJ50PC50 470 Kg				
			Main T-Box Ass'y				
			3M-016882				
SPARE PARTS			REMARK				
Note: Others not mentioned in this specification shall be in accordance with HHI standard. Above technical data are only design values and shall be guaranteed with tolerance of applicable standard.			Date	DSND	CHKD	CHKD	APPD
			2004.01.27	KIM R.G.		KIM O.J.	KANG K.G.

HHI W230-131-1 * In case of Inverter or V.V.V.F Motor:Performance data is based on sine wave tests. A4(210mm X 297mm)

	<h1 style="margin:0;">TEFC</h1> <h2 style="margin:0;">THREE PHASE INDUCTION MOTOR</h2>	TYPE	(1) TNB , TDB CAST IRON FRAME
-----------------------------------------------------------------------------------	----------------------------------------------------------------------------------------	-------------	----------------------------------

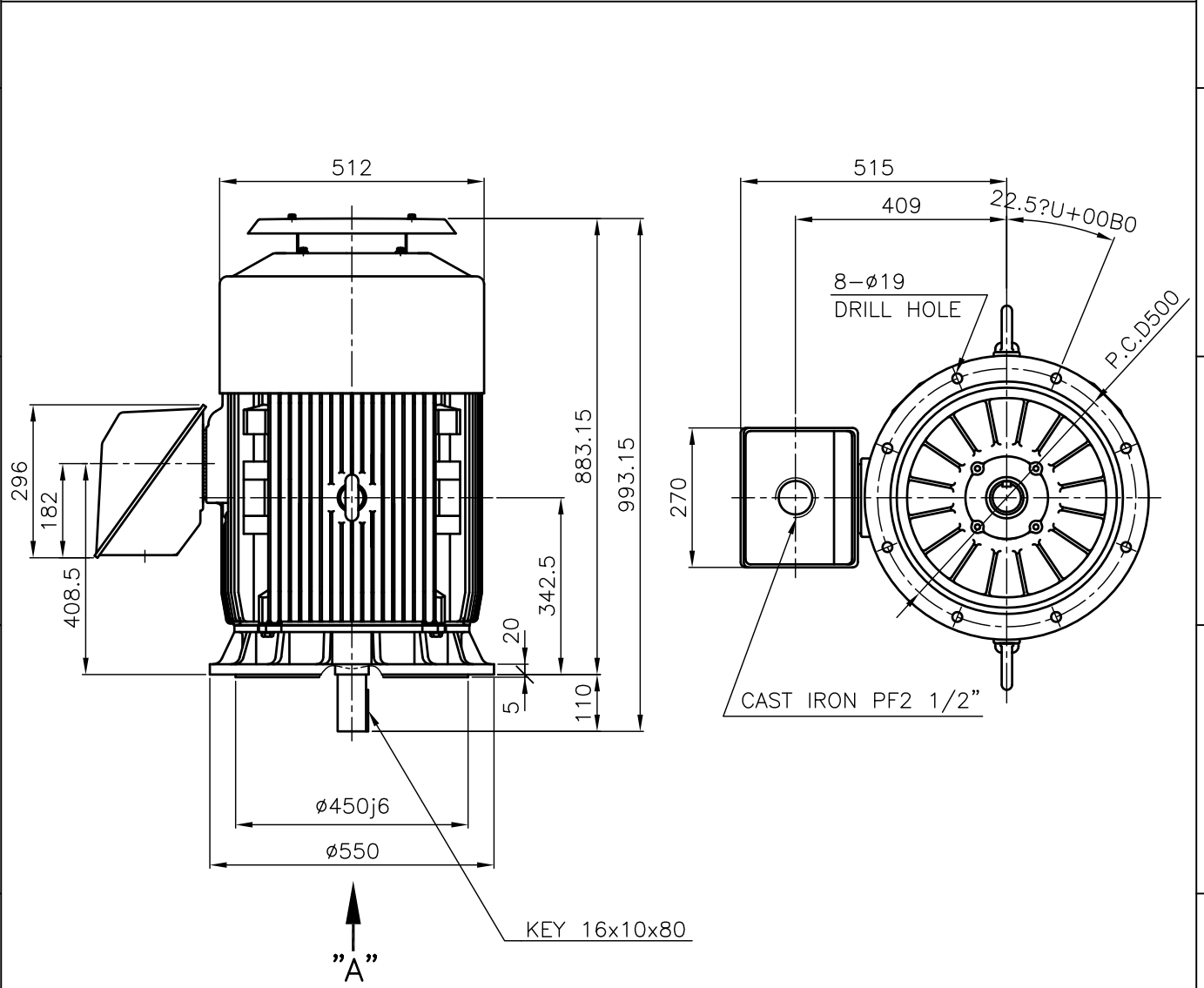



NOTE

1.TOLERANCE :

RABBET DIAMETER	ø450j6	±0.020
SHAFT DIAMETER	ø55m6	+0.030 +0.011
KEYWAY WIDTH	16P9	-0.018 -0.061
KEYWAY DEPTH	6	+0.2 0

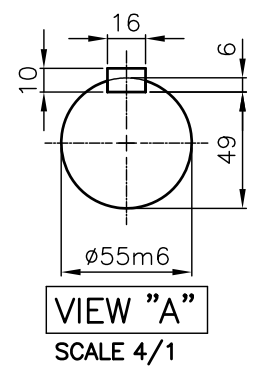
2.The type (1)-"TNB, TDB" is for HHI's standard products and it can be changed for customer's requirements or detail designing.



				TEFC STANDARD		
APPD BY	KANG K.J.	UNIT	MM	SUBJECT	KS Fr.250 TEFC	
CHKD BY	KIM O.J.	SCALE	1/13			
CHKD BY	LEE N.D.	PROJEC'N	3rd Angle	TITLE	OUTLINE THREE-PHASE INDUCTION MOTOR	
DSND BY	KIM RYANG GYU	DATE	2007.03.23			
				REF. NO	L3-SERIES	Sheet No. of
				DWG NO	TJ50PC50	Revision No.



PERFORMANCE CURVE

CURVE NO.

P-TNBJ5S02075

TYPE :		
RATED TORQUE :	20.5	Kg.m
GD2 OF MOTOR :	2.1	Kg.m ²
(ALLOWABLE) GD2 OF LOA :	31.5	Kg.m ²

75 kW	2 P	60 Hz	
RATED SPEED :		3570 RPM	
VOLTAGE	440V	380 V	220V
RATED CURRENT	118.6A	137.3 A	237.2A

SPEED VS TORQUE & CURRENT CURVE

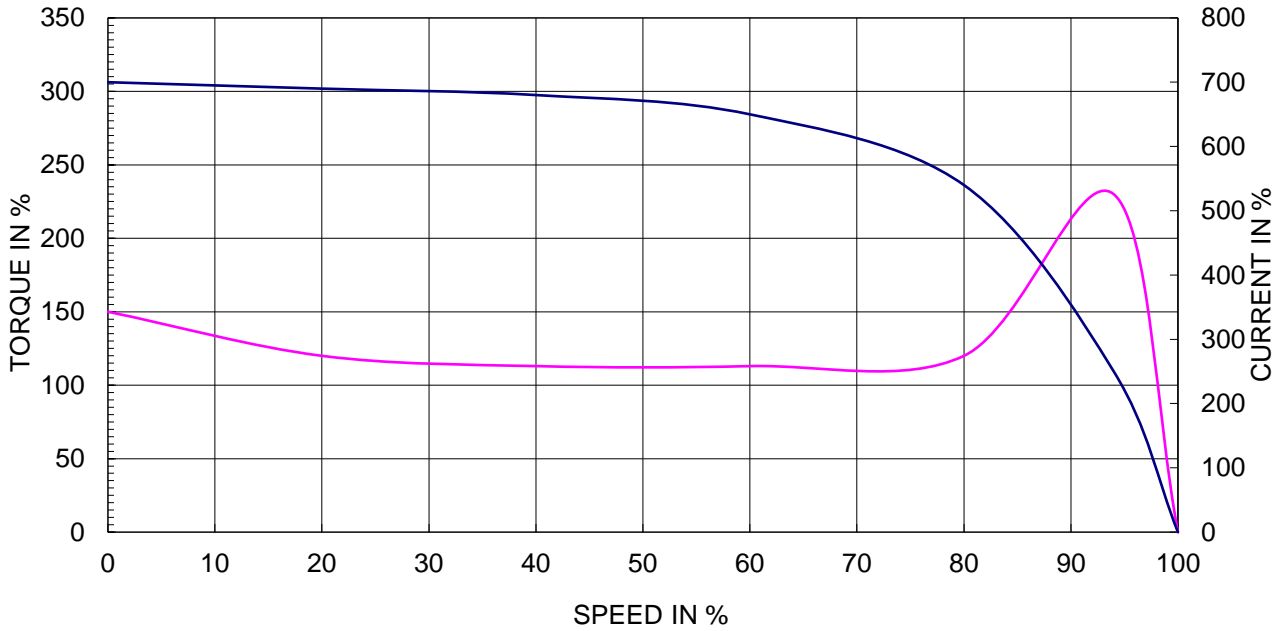

OUTPUT VS EFF., P.F & CURRENT CURVE

