

		<b>DATA SHEET</b> of <b>AC INDUCTION MOTOR</b>				<b>75 HP - 8 P</b> <b>TE</b>			
		DESIGN NO : <b>KS C4202-1996</b>							
Model No.or RFQ No.		Item No.		Rev. No.		[ 0 ]			
Project Name		Project No.		Quantity :					
GENERAL SPECIFICATION				PERFORMANCE DATA					
Frame No.		280S		Output		75 HP 55 KW			
Type		TNB		Poles		8 P			
Enclosure(Protection)		Totally Enclosed (IP IP54 )		Rotor Type		Squirrel Cage			
Cooling Method		IC411(FC)		Starting Method(*)		<input checked="" type="checkbox"/> D.O.L. <input type="checkbox"/> Y-Δ			
Frequency		60 Hz		Rated Voltage		440 V      380 V      220 V			
Phase		3 φ		Current		Rated Load			
Insulation Class		<input checked="" type="checkbox"/> F <input type="checkbox"/> B <input type="checkbox"/> H				Start'g-D.O.L.		95.3 A      110.3 A      190.6 A 552.7 A      639.9 A      1,105.4 A	
Temp. Rise at full load (by resistance method)				Efficiency					
at 1.0 S.F		105 °C		50% Load		91.8 %			
Location		<input type="checkbox"/> Indoor <input type="checkbox"/> Outdoor		75% Load		92.7 %			
Altitude		Less than 1000 meter		100% Load		92.7 %			
Humidity		Less than 80 %		Power Factor					
Ambient Temp.		40 °C (Max.)		50% Load		72.5 %			
Duty		CONT.(S1)		75% Load		78.0 %			
Service Factor		1.00		100% Load		81.7 %			
Electric Design		NEMA Design B		Speed at Rated Load		880 RPM / SLIP 2.22 %			
Construction		<input type="checkbox"/> B3 <input type="checkbox"/> B5 <input type="checkbox"/> V1 <input type="checkbox"/>		Torque (D.O.L)					
Bearing		Type		Anti-friction		Rated			
		DE/ODE		6318C3 \ 6316C3		Starting			
		Lubricant		GREASE(ALVANIA#2)		Break down			
External Thrust		Not applicable		Allowable Load GD <sup>2</sup> referred to motor shaft					
Coupling Method		<input checked="" type="checkbox"/> Direct <input type="checkbox"/> V-Belt		507.100 Kg.m <sup>2</sup>					
Shaft Extension		<input checked="" type="checkbox"/> Single <input type="checkbox"/> Double		Motor GD <sup>2</sup>					
Terminal Box		Main		<input type="checkbox"/> Steel <input checked="" type="checkbox"/> Cast Iron		Noise Level (dB(A))			
		Aux.		<input type="checkbox"/> Yes <input checked="" type="checkbox"/> No		Vibration(Velocity)			
		Location		<input checked="" type="checkbox"/> Left <input type="checkbox"/> Right (Viewed from Drive End)		Starting Duty		Cold 2 times \ Hot 1 time	
Paint		Munsell No.		4.0PB5.4/5.5(VL-451)					
Application				SUBMITTAL DRAWING					
Area Classification		Not applicable		Outline Dimension Drawing \ Motor Weight(Approx.)					
Applicable Standard		KS		<input type="checkbox"/> B3      TJ8SAP51      700 Kg		<input type="checkbox"/> B5      TJ80BP51      740 Kg			
Inspection and Performance Test		HHI Stand.		Maker Test Report		<input type="checkbox"/> V1      TJ80PP51      740 Kg			
		ACCESSORIES(OPTION ITEM)				Main T-Box Ass'y			
				3M-016882					
SPARE PARTS				REMARK					
Note: Others not mentioned in this specification shall be in accordance with HHI standard. Above technical data are only design values and shall be guaranteed with tolerance of applicable standard.				Date		DSND		CHKD	
				2004.01.27		KIM R.G.			

본 도면은 현대중공업(주) 재산이므로  
허가없이 복사할 수 없음 (취급유의)

THIS DRAWING IS PROPRIETARY TO HHI. NO PART OF THIS DRAWING  
MAYBE REPRODUCED WITHOUT THE PERMISSION OF HHI.

	TEFC	TYPE	(1) TNB , TDB
THREE PHASE INDUCTION MOTOR			CAST IRON FRAME

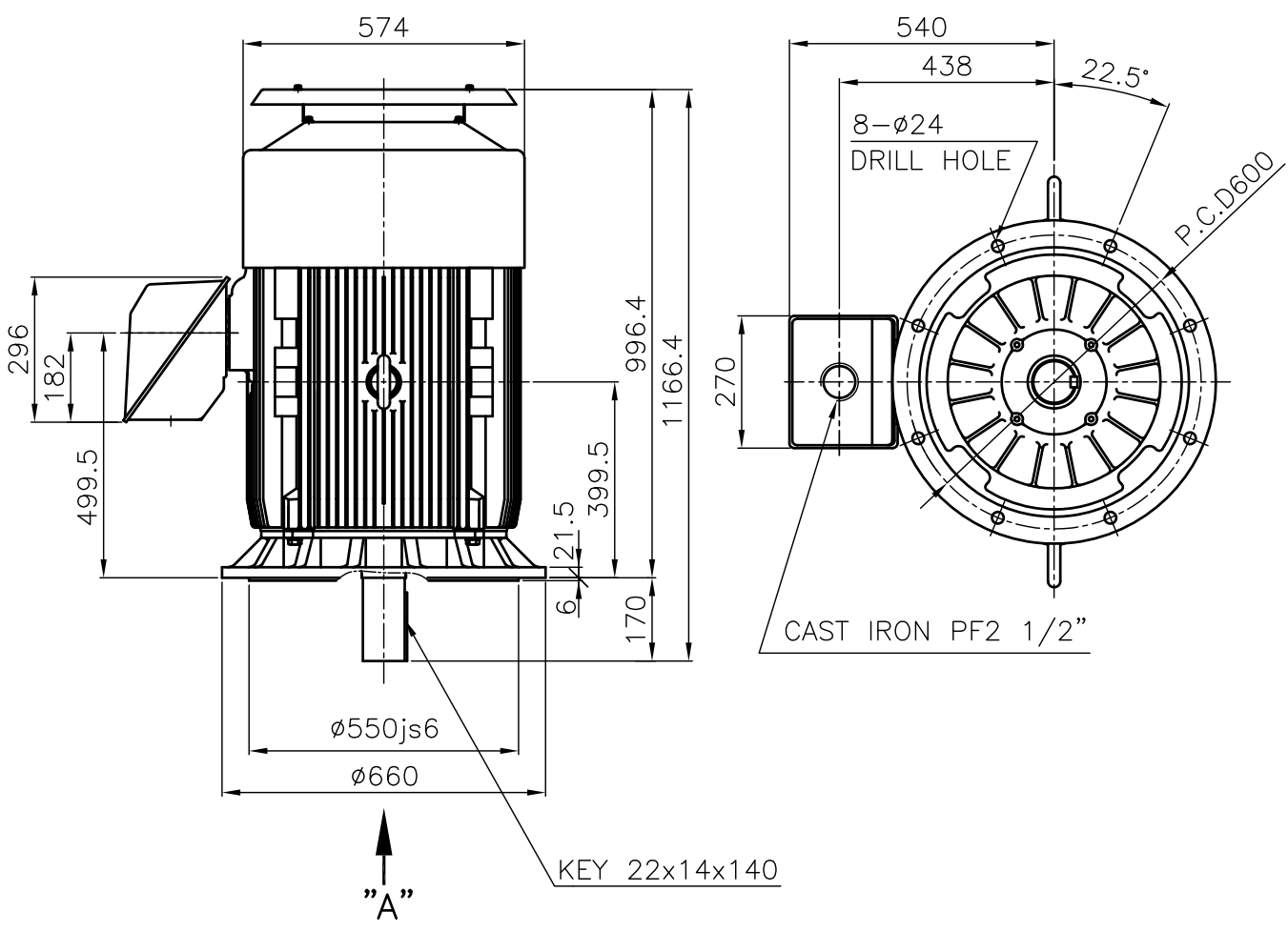

**NOTE**

1.TOLERANCE :

RABBET DIAMETER	ø550js6	±0.022
SHAFT DIAMETER	ø85m6	+0.035 +0.013
KEYWAY WIDTH	22P9	-0.022 -0.074
KEYWAY DEPTH	9	+0.2 0

2.The type (1)-"TNB, TDB" is for HHI's standard products and it can be changed for customer's requirements or detail designing.

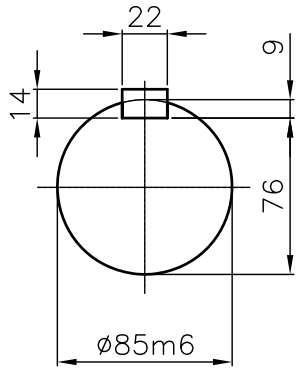

**VIEW "A"**  
SCALE 4/1

				TEFC STANDARD		
APPD BY	KANG K.J.	UNIT	MM	SUBJECT	KS Fr.280 TEFC	CAD PROJ \ FILE
CHKD BY	KIM O.J.	SCALE	1/15			MMSTDMTR/TJ80PP51
CHKD BY	LEE N.D.	PROJEC'N	3rd Angle	<b>OUTLINE</b> THREE-PHASE INDUCTION MOTOR		
DSND BY	KIM RYANG GYU	DATE	2007.03.23			
				REF. NO	L3-SERIES	Sheet No. of
				DWG NO	TJ80PP51	Revision No. 0



# PERFORMANCE CURVE

CURVE NO.

P-TNBJ8S08055

TYPE :		
RATED TORQUE :	60.9	Kg.m
GD2 OF MOTOR :	9.9	Kg.m <sup>2</sup>
(ALLOWABLE) GD2 OF LOA	507.1	Kg.m <sup>2</sup>

55 kW	8 P	60 Hz	
RATED SPEED :		880 RPM	
VOLTAGE	440V	380 V	220V
RATED CURRENT	95.3A	110.3 A	190.6A

SPEED VS TORQUE & CURRENT CURVE

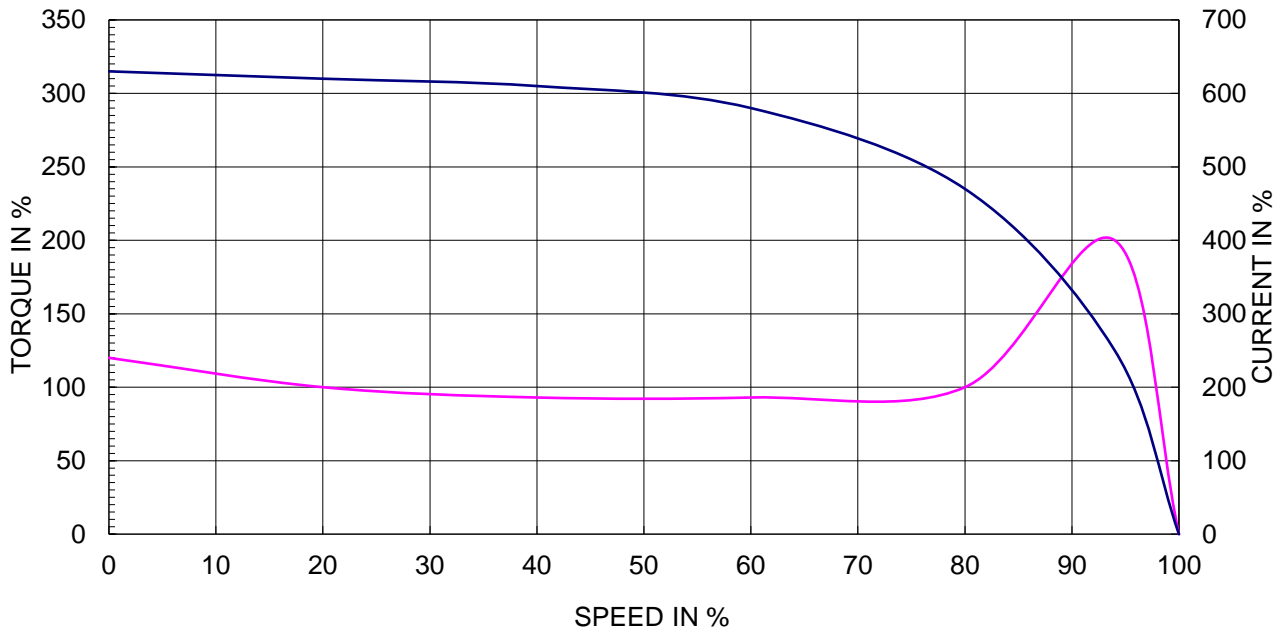

OUTPUT VS EFF., P.F & CURRENT CURVE

