

Model No.or RFQ No.		Item No.	Rev. No. [0]	
Project Name		Project No.	Quantity sets	
GENERAL SPECIFICATION		PERFORMANCE DATA		
Frame Size	200LL	Rated Output	37 kW 50 HP	
Type	HLP-37/6	Number of Poles	6	
Enclosure(Protection)	Totally Enclosed (IP55)	Rotor Type	Squirrel Cage	
Method of Cooling	IC411(FC)	Starting Method*	<input checked="" type="checkbox"/> D.O.L <input type="checkbox"/> Y- Δ	
Rated Frequency	60 Hz	Rated Voltage	440 V	380 V 220 V
Number of Phases	3	Current	Full Load	64.5 A 74.7 A 129.0 A
Insulation Class	<input checked="" type="checkbox"/> F <input type="checkbox"/> B <input type="checkbox"/> H	Locked-rotor**	750 %	750 % 750 %
Temp. Rise at full load (by resistance method)		Efficiency		
at 1.0 S.F 80 deg. C		50% Load 94.0 %		
Motor Location	<input checked="" type="checkbox"/> Indoor <input type="checkbox"/> Outdoor	75% Load 94.3 %		
Altitude	Less than 1000 meter	100% Load 94.1 %		
Relative Humidity	Less than 80 %	Power Factor(p.u)		
Ambient Temp.	40 deg. C (Max.)	50% Load 0.685		
Duty Type	Continuous (S1)	75% Load 0.765		
Service Factor	1.15	100% Load 0.800		
Mounting	<input checked="" type="checkbox"/> B3 <input type="checkbox"/> B5 <input type="checkbox"/> V1 <input type="checkbox"/> B3/B5	Speed at Full Load	1175 r.p.m	
Bearing	Type	Anti-Friction		
	DE/N-DE	6313ZC3 / 6211ZC3		
	Lubricant	Grease(Gadus S2 V 100 2)		
External Thrust	Not applicable			
Coupling Method	<input checked="" type="checkbox"/> Direct <input type="checkbox"/> V-Belt	Torque		
Shaft Extension	<input checked="" type="checkbox"/> Single <input type="checkbox"/> Double	Full Load 30.7 kg·m		
Terminal Box	Main	<input type="checkbox"/> Steel <input checked="" type="checkbox"/> Cast Iron		
	Aux.	<input type="checkbox"/> Yes <input checked="" type="checkbox"/> No		
Location		Refer to Outline Drawing		
Application		Moment of Inertia (J)		
Area classification	Non-Hazardous	Load(Max.) 30.700 kg·m ²		
Type of Ex-Protection	Not applicable	Motor 0.781 kg·m ²		
Applicable Standard	KS,IEC, NEMA MG1 Part30(Vpeak)	Sound Pressure Level (No-load & mean value at 1m from motor)		
		72 dB(A)		
		Vibration		
		2.2 mm/sec (r.m.s)		
		Permissible number of consecutive starts		
		Cold 3 times		
		Hot 2 times		
		Paint	Munsell No. 4.4PB5.5/5.6(VL-451)	
ACCESSORIES		SUBMITTAL DRAWING		
		Outline Dimension Drawing \ Motor Weight(Approx.)		
		B3	LM-T1207B3PL001	320 kg
		B5	LM-T1207B5PL001	350 kg
		V1	LM-T1207V1PL001	350 kg
		B3/B5	LM-T1207B4PL001	350 kg
		Main T-Box Ass'y	3M-145864	
SPARE PARTS		REMARK		
		Premium Efficiency		
		*. For use on PWM VFD 10:1VT, 3:1CT@1.0S.F&F Temp. rise		
		Date	DSND	CHKD
		2015-09-05	R.G. KIM	- O.J. KIM S.H. GO

Note: Others not mentioned in this data sheet shall be in accordance with maker standard.
 Above technical data are only design values and shall be guaranteed with tolerance of applicable standard.
 Inspection and performance test shall be maker standard, if not mentioned.
 * In case of Inverter-Fed Motor, performance data is based on sine wave tests.
 ** Data is based on when the motor is supplied at rated voltage & frequency, and the data is expressed as a percentage of full-load value.

Type	:	HLP-37/6
Full Load Torque	:	30.7 Kg.m
Motor moment of Inertia (J)	:	0.781 Kg.m ²
Load moment of Inertia (J)	:	30.700 Kg.m ²

37 kW	6 P	60 Hz	
Speed at Full Load :		1175 RPM	
Rated Voltage	440V	380V	220V
Full Load Current	64.5A	74.7A	129.0A

SPEED VS TORQUE & CURRENT CURVE

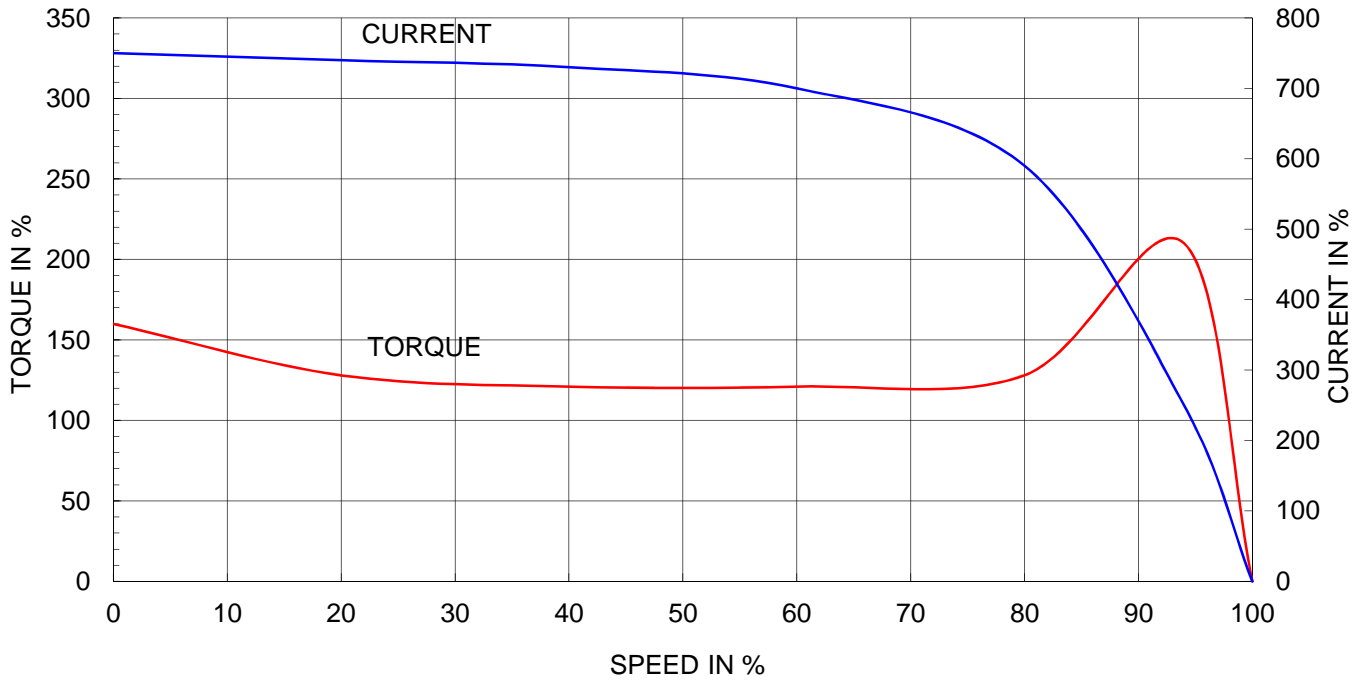

OUTPUT VS EFF., P.F & CURRENT CURVE

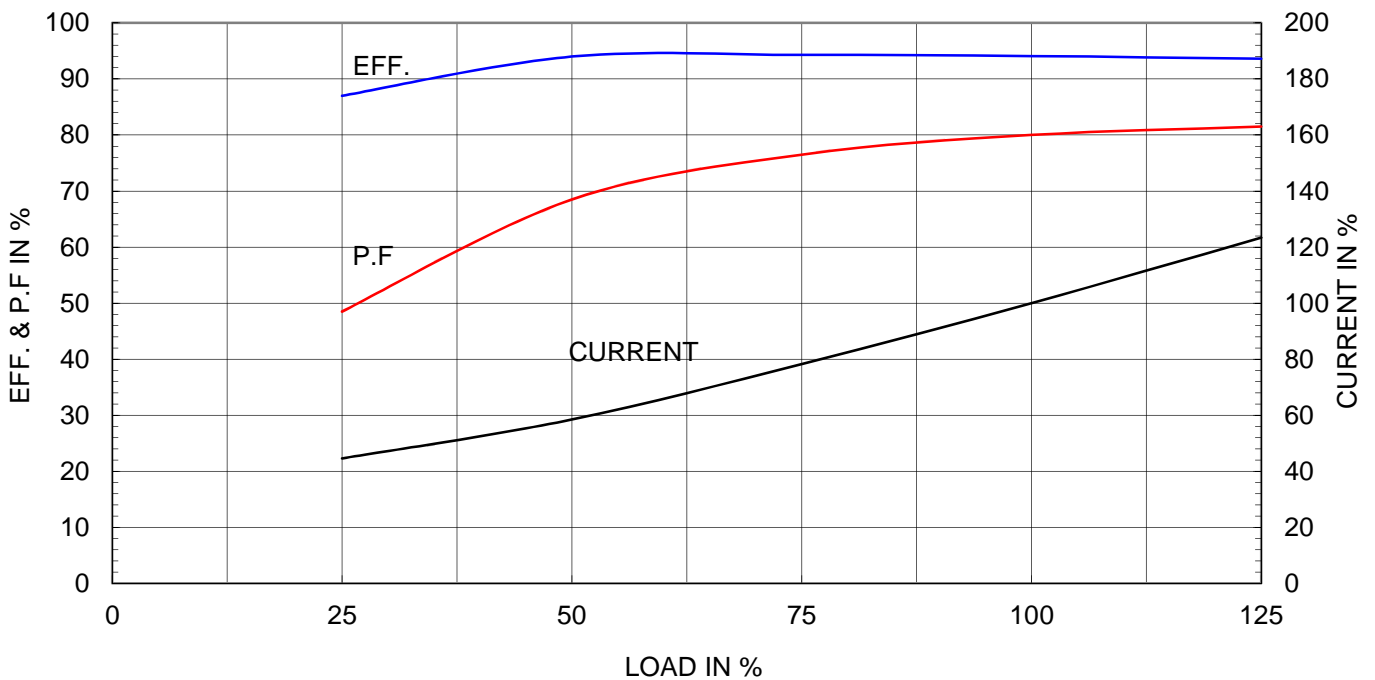



TEFC

THREE PHASE INDUCTION MOTOR

TYPE

HL, HS

CAST IRON FRAME

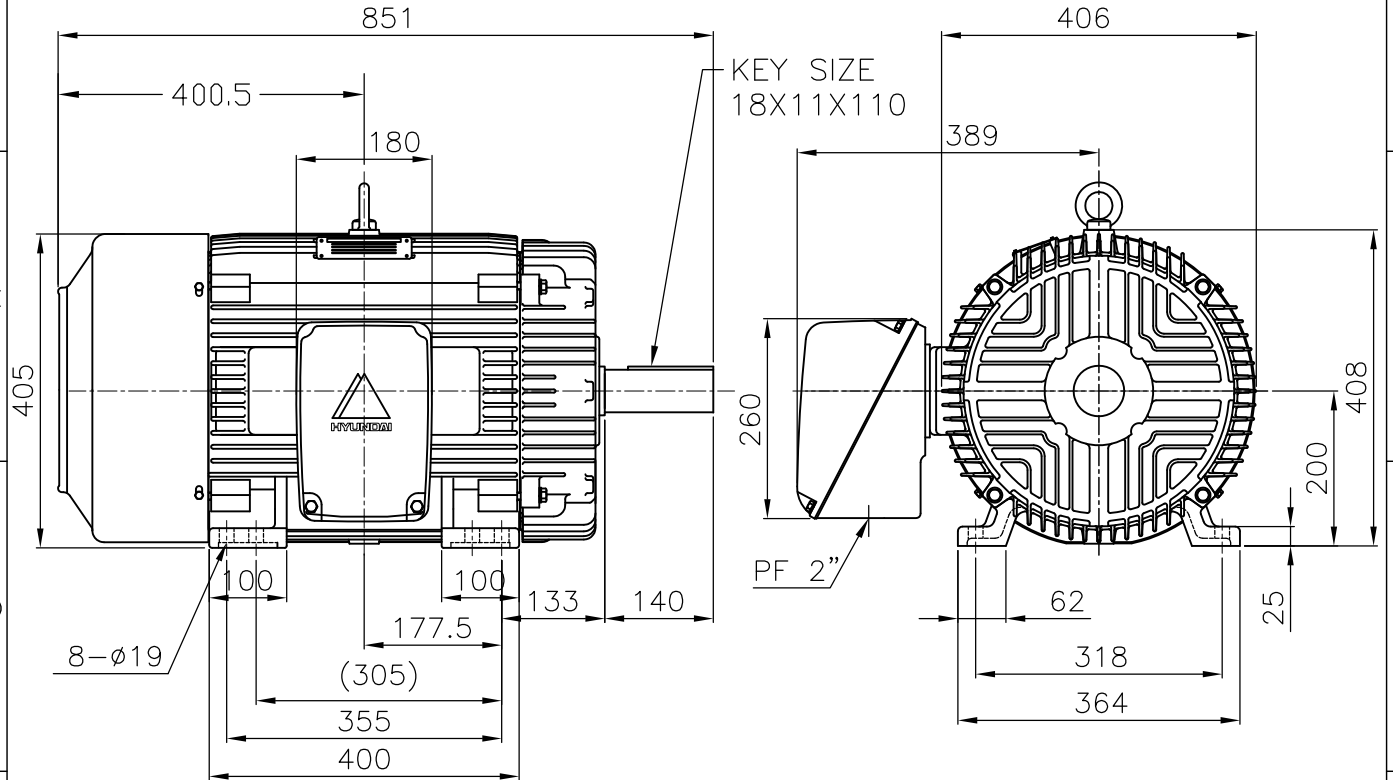

NOTE

1.TOLERANCE :

CENTER HEIGHT	200	⁺⁰ / _{-0.5}
BASE HOLES	ø19	^{+0.43} / ₋₀
SHAFT DIAMETER	ø60	^{+0.030} / _{+0.011}
KEYWAY WIDTH	18	⁺⁰ / _{-0.043}
KEYWAY DEPTH	7	^{+0.2} / ₊₀

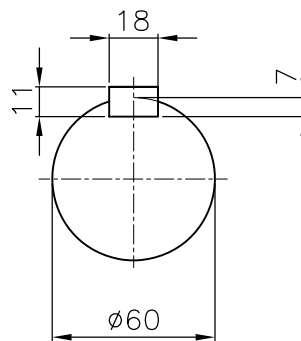

* STEEL CONDUIT BOX

APPD BY	J. H. KIM	UNIT	mm	SUBJECT	KS 200LL 4,6P	CAD PROJ \ FILE
CHKD BY	K. S. LEE	SCALE	1/10			XSDNKS\B2000AB10
CHKD BY	I. K. KIM	PROJEC'N	3rd Angle	TITLE OUTLINE		
DSND BY	S. M. KIM	DATE	2002.10.31			
				REF. NO	B2000AB12	Sheet No. of
				DWG NO	LM-T1207B3PL001	Revision No. 1

본 도면은 현대중공업(주) 재산이므로
허가없이 복사할 수 없음 (취급유의)

THIS DRAWING IS PROPRIETARY TO HHI. NO PART OF THIS DRAWING
MAYBE REPRODUCED WITHOUT THE PERMISSION OF HHI.

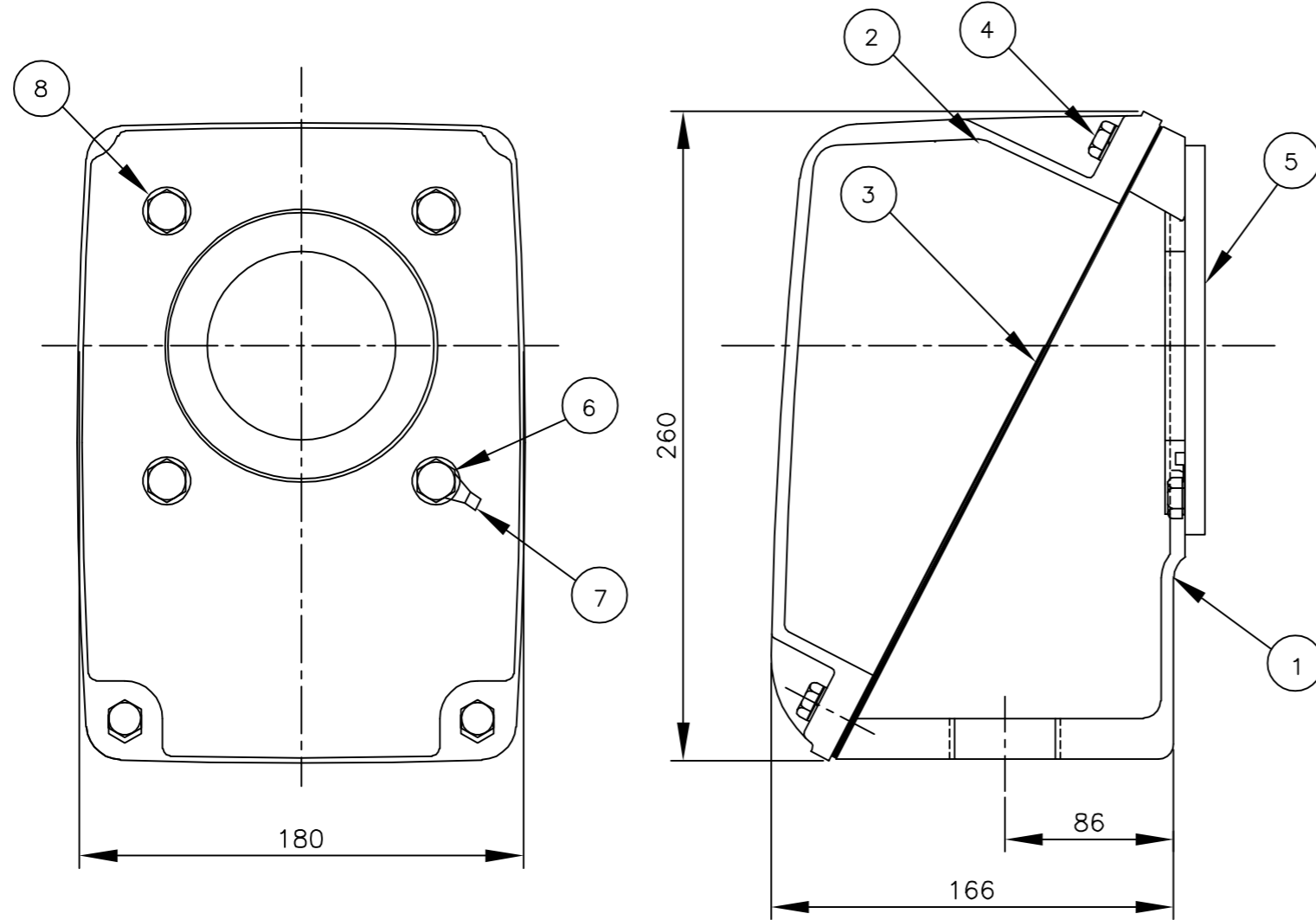

PT	DESCRIPTION	MATERIAL	DIMENSION	Q,TY
1	CONDUIT BOX	FC20		1
2	C/B COVER	FC20		1
3	GASKET(COVER)	N.B.R	T2X170X210	1
4	SCREW(COVER)	S45C	M8XL20	4
5	GASKET(C/B)	N.B.R		1
6	SCREW(C/B)	S45C	M8XL20	4
7	TERMINAL GROUND	CU	T1.6	1
8	WASHER	S45C	M8 X L10	4

▽	50S
▽▽	12.5S
▽▽▽	3.2S
▽▽▽▽	0.4S

REV	DATE	CONTENTS	REVD BY	CHKD BY	CHKD BY	APPD BY
1	12.01.27	CABLE 및 TAP 표시 삭제.	김양규	김옥진	김진홍	강경중

일반가공공차		일반제관공차	
1-4	±0.1	6-30	±0.5
4-18	±0.2	30-120	±0.8
18-63	±0.3	120-315	±1.2
63-250	±0.5	315-1000	±2.0
250-	±0.8	1000-	±3.0

Q'TY	DESCRIPTION	MATERIAL	DIMENSION	WEIGHT	PART NO.	REMARK	NO.
APPD BY	강경중	UNIT	mm	SUBJECT	IEC-Fr.200		DWG SIZE
CHKD BY	이노덕	SCALE	1/2	TITLE	Main Terminal Box Assembly		A3 (1:2)
CHKD BY	김인규	PROJEC'N	3각법(3rd Angle)	REF. NO	227B8003CB5	Sheet No.	of
DSND BY	김은성	DATE	2011-08-30	DWG NO	3M-145864	Revision No.	1