



AC INDUCTION MOTOR DATA SHEET

Model No.or RFQ No.		Item No.	Rev. No. [0]				
Project Name		Project No.	Quantity sets				
GENERAL SPECIFICATION			PERFORMANCE DATA				
Frame Size	280LL		Rated Output	160 kW 214 HP			
Type	HLP-160/6		Number of Poles	6			
Enclosure(Protection)	Totally Enclosed (IP55)		Rotor Type	Squirrel Cage			
Method of Cooling	IC411(FC)		Starting Method*	<input checked="" type="checkbox"/> D.O.L <input type="checkbox"/> Y- Δ			
Rated Frequency	60 Hz		Rated Voltage	440 V 380 V 220 V			
Number of Phases	3		Current	Full Load 254.8 A 295.1 A 509.7 A			
Insulation Class	<input checked="" type="checkbox"/> F <input type="checkbox"/> B <input type="checkbox"/> H		Locked-rotor**	800 % 800 % 800 %			
Temp. Rise at full load (by resistance method)			Efficiency				
at 1.0 S.F 80 deg. C			50% Load 95.7 %				
Motor Location <input checked="" type="checkbox"/> Indoor <input type="checkbox"/> Outdoor			75% Load 96.0 %				
Altitude Less than 1000 meter			100% Load 95.8 %				
Relative Humidity Less than 80 %			Power Factor(p.u)				
Ambient Temp. 40 deg. C (Max.)			50% Load 0.726				
Duty Type Continuous (S1)			75% Load 0.814				
Service Factor 1.15			100% Load 0.860				
Mounting <input type="checkbox"/> B3 <input type="checkbox"/> B5 <input type="checkbox"/> V1 <input type="checkbox"/> B3/B5			Speed at Full Load 1185 r.p.m				
Bearing	Type	Anti-Friction		Torque			
	DE/N-DE	6318C3 / 6316C3		Full Load 131.5 kg·m			
	Lubricant	Grease(Gadus S2 V 100 2)		Locked-rotor** 150 %			
External Thrust Not applicable			Breakdown** 230 %				
Coupling Method <input checked="" type="checkbox"/> Direct <input type="checkbox"/> V-Belt			Moment of Inertia (J)				
Shaft Extension <input checked="" type="checkbox"/> Single <input type="checkbox"/> Double			Load(Max.) 224.250 kg·m ²				
Terminal Box	Main	<input type="checkbox"/> Steel <input checked="" type="checkbox"/> Cast Iron		Motor 7.288 kg·m ²			
	Aux.	<input type="checkbox"/> Yes <input checked="" type="checkbox"/> No		Sound Pressure Level (No-load & mean value at 1m from motor)			
Location Refer to Outline Drawing			80 dB(A)				
Application			Vibration 2.2 mm/sec (r.m.s)				
Area classification Non-Hazardous			Permissible number of consecutive starts				
Type of Ex-Protection Not applicable			Cold 3 times				
Applicable Standard KS,IEC, NEMA MG1 Part30(Vpeak)			Hot 2 times				
			Paint	Munsell No. 4.4PB5.5/5.6(VL-451)			
ACCESSORIES			SUBMITTAL DRAWING				
			Outline Dimension Drawing \ Motor Weight(Approx.)				
			B3	LM-T1287B3PL001	1100 kg		
			B5	LM-T1287B5PL001	1170 kg		
			V1	LM-T1287V1PL001	1170 kg		
			B3/B5	LM-T1287B4PL001	1135 kg		
			Main T-Box Ass'y		3M-016882		
SPARE PARTS			REMARK				
			Premium Efficiency				
			*. For use on PWM VFD 10:1VT, 3:1CT@1.0S.F&F Temp. rise				
			Date	DSND	CHKD	CHKD	APPD
			2015-09-05	R.G. KIM	-	O.J. KIM	S.H. GO

Note: Others not mentioned in this data sheet shall be in accordance with maker standard.
 Above technical data are only design values and shall be guaranteed with tolerance of applicable standard.
 Inspection and performance test shall be maker standard, if not mentioned.
 * In case of Inverter-Fed Motor, performance data is based on sine wave tests.
 ** Data is based on when the motor is supplied at rated voltage & frequency, and the data is expressed as a percentage of full-load value.

Type	:	HLP-160/6
Full Load Torque	:	131.5 Kg.m
Motor moment of Inertia (J)	:	7.288 Kg.m ²
Load moment of Inertia (J)	:	224.250 Kg.m ²

160 kW	6 P	60 Hz	
Speed at Full Load :		1185 RPM	
Rated Voltage	440V	380V	220V
Full Load Current	254.8A	295.1A	509.7A

SPEED VS TORQUE & CURRENT CURVE

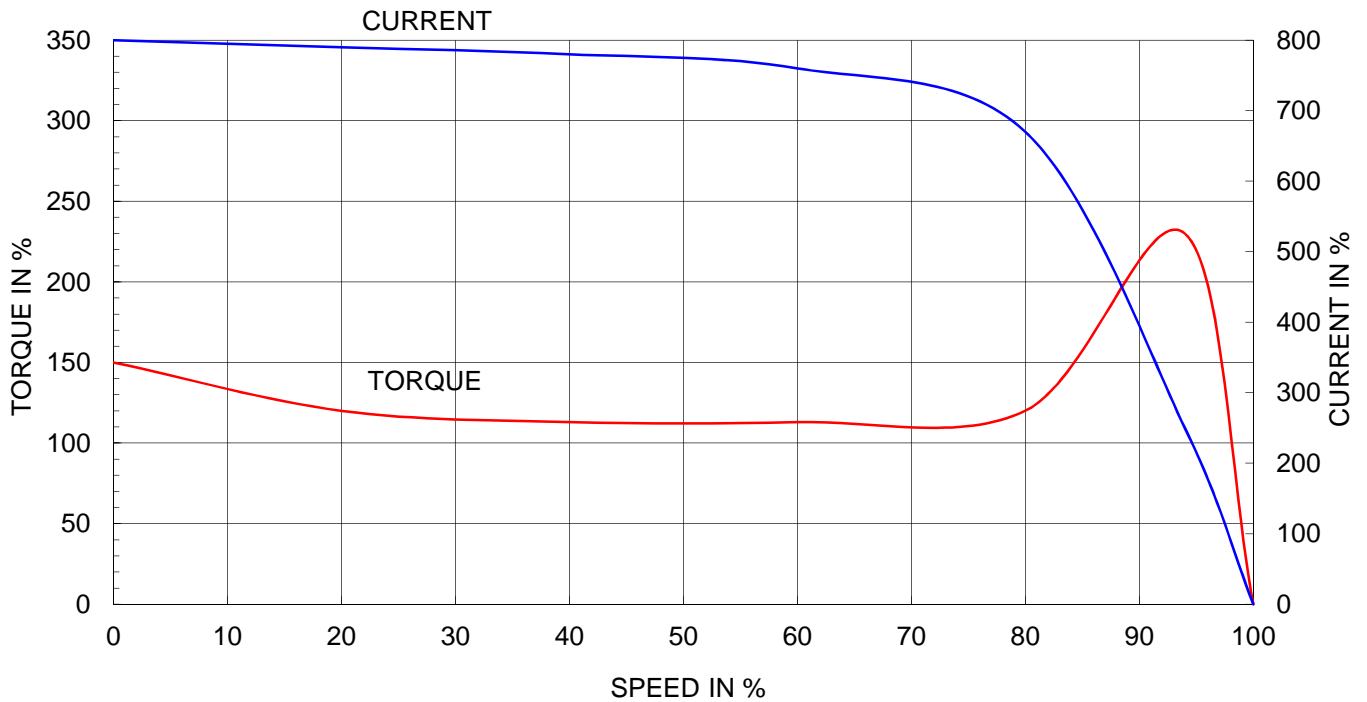

OUTPUT VS EFF., P.F & CURRENT CURVE

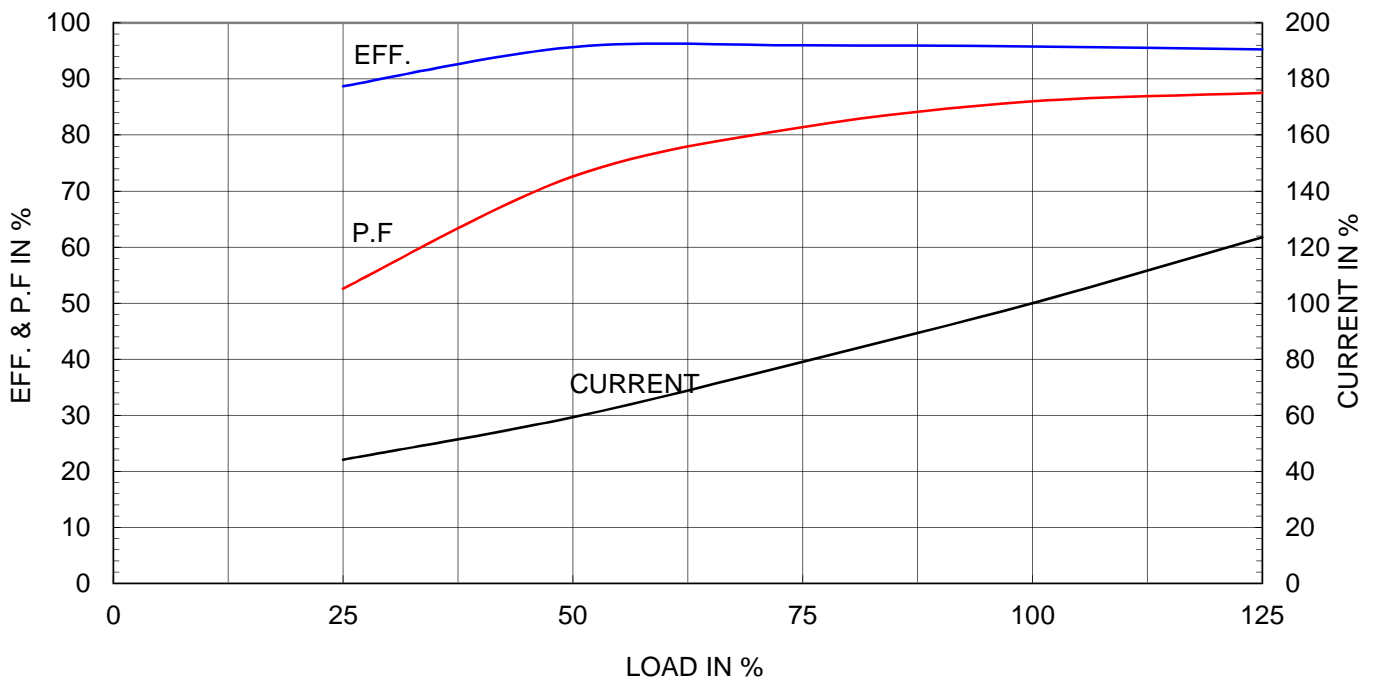

본 도면은 현대일렉트릭(주) 재산이므로
허가없이 복사할 수 없음 (취급주의)

THIS DRAWING IS PROPRIETARY TO HYUNDAI ELECTRIC. NO PART OF THIS DRAWING
MAY BE REPRODUCED WITHOUT THE PERMISSION OF HYUNDAI ELECTRIC.

	1	2	3	4				
▽	50S	REV	DATE	CONTENTS	REVD BY	CHKD BY	CHKD BY	APPD BY
▽▽	12.5S							
▽▽▽	3.2S							
▽▽▽▽	0.4S							

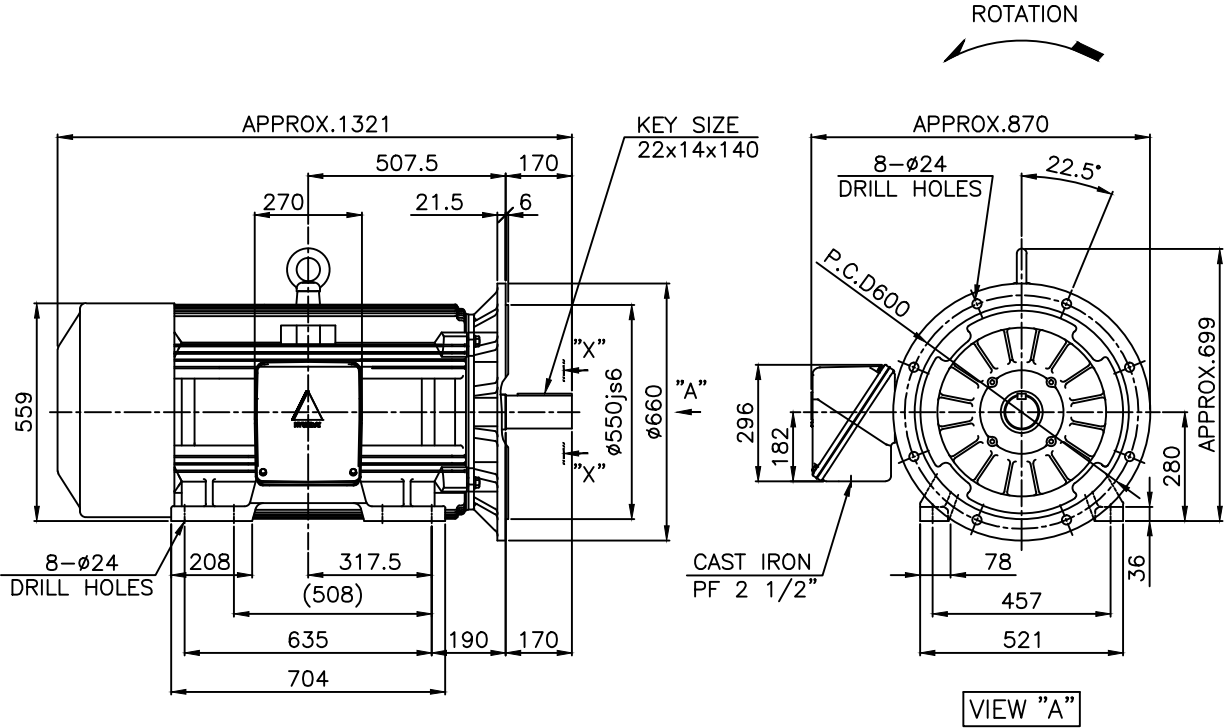

NOTE

1.TOLERANCE :

CENTER HEIGHT	280	0	-1.0
BASE HOLES	$\phi 24$	+0.52	0
FLANGE HOLES	$\phi 24$	+0.52	0
RABBET DIAMETER	$\phi 550$	± 0.022	
SHAFT DIAMETER	$\phi 85$	+0.035	+0.013
KEYWAY WIDTH	22	-0.022	-0.074
KEYWAY DEPTH	9	+0.2	0
KEY WIDTH	22	0	-0.052
KEY HEIGHT	14	0	-0.110

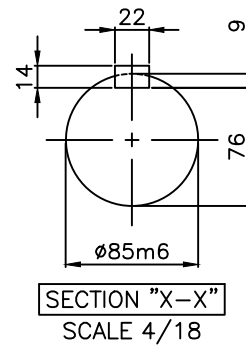

APPD BY	S.K.HAN	UNIT	mm	SUBJECT	KS, IEC Fr.280LL-4~20P	DWG SIZE	A4 (1:18)
CHKD BY	S.Y.KIM	SCALE	1/18	TITLE	OUTLINE		
CHKD BY	R.G.KIM	PROJEC'N	3각법 (3rd Angle)	REF. NO		Sheet No.	of
DSND BY	S.H.YUN	DATE	2018-08-29	DWG NO	LM-T1287B4PL001	Revision No.	1

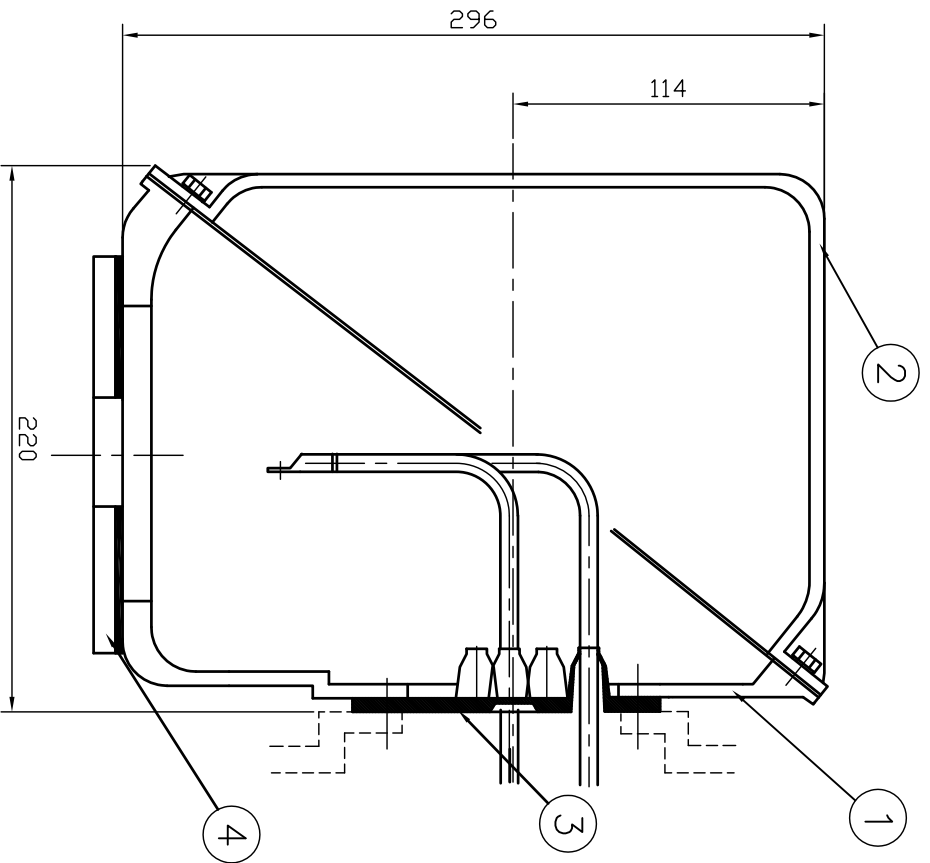
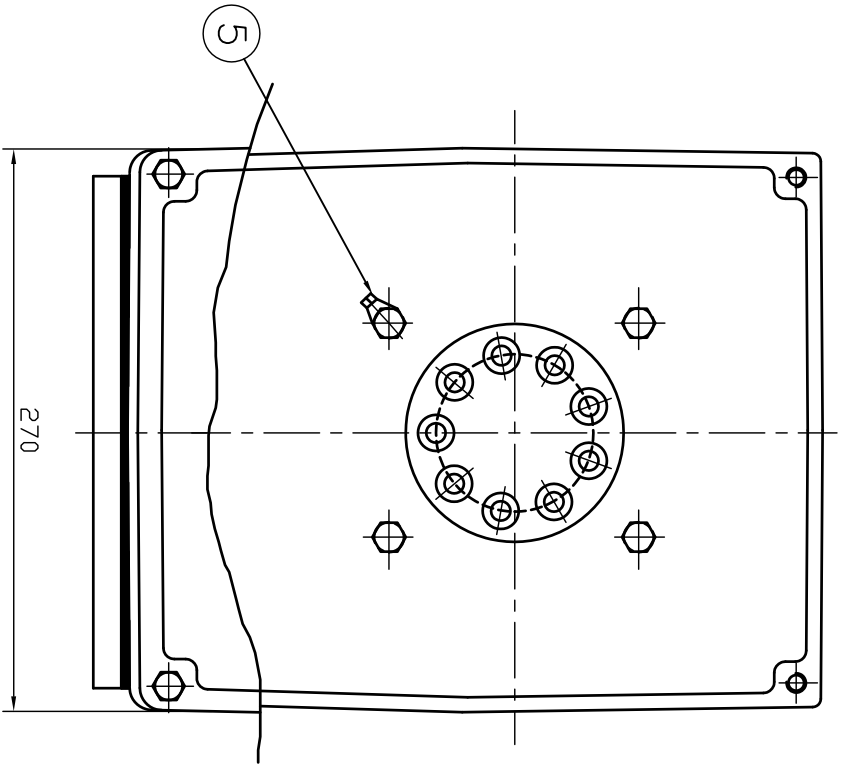

REV	DATE	CONTENTS	REVD BY	CHKD BY	Q.P CHK	APPD BY
1						
2						
3						
4						

QTY	DESCRIPTION	MATERIAL	DIMENSION	WEIGHT	PART NO.	REMARK	NO.
1	EARTH TERMINAL LUG						5
1	CABLE ENTRY PLATE						4
1	GASKET	NBR					3
1	TERMINAL BOX COVER	CAST IRON					2
1	TERMINAL BOX BODY	CAST IRON					1
APPD BY	권진오	UNIT	MM				
Q.P CHK	주영철	SCALE	NONE				
CHKD BY	권오철	PROJEC'N	3 레벨(3rd Angle)				
DSND BY	김현태	DATE	92.06.05				
TITLE		SUBJECT					
TERMINAL BOX ASS'Y		HLA6 - 250,280Fr.					
REF. NO		CAD PROJ \ FILE					
DWG NO		T-BOX-M \ 38016882					
3M-016882							
Revision No.		Sheet No. of					

