

		DATA SHEET of AC INDUCTION MOTOR				175 HP - 4 P TE	
						DESIGN NO : KS C4202-1996	
Model No.or RFQ No.		Item No.		Rev. No.	[0]		
Project Name		Project No.		Quantity :			
GENERAL SPECIFICATION			PERFORMANCE DATA				
Frame No.	280M		Output	175 HP 132 KW			
Type	TNB		Poles	4 P			
Enclosure(Protection)	Totally Enclosed (IP IP54)		Rotor Type	Squirrel Cage			
Cooling Method	IC411(FC)		Starting Method(*)	<input checked="" type="checkbox"/> D.O.L. <input type="checkbox"/> Y-Δ			
Frequency	60 Hz		Rated Voltage	440 V	380 V	220 V	
Phase	3 φ		Current	Rated Load	209.3 A	242.3 A	418.5 A
Insulation Class	<input checked="" type="checkbox"/> F <input type="checkbox"/> B <input type="checkbox"/> H			Start'g-D.O.L	1,423.0 A	1,647.7 A	2,845.9 A
Temp. Rise at full load (by resistance method)			Efficiency				
at 1.0 S.F			105 °C				
Location	<input type="checkbox"/> Indoor <input type="checkbox"/> Outdoor		50% Load		92.1 %		
Altitude	Less than 1000 meter		75% Load		93.1 %		
Humidity	Less than 80 %		100% Load		93.0 %		
Ambient Temp.	40 °C (Max.)		Power Factor				
Duty	CONT.(S1)		50% Load		82.0 %		
Service Factor	1.00		75% Load		87.0 %		
Electric Design	NEMA Design B		100% Load		89.0 %		
Construction	<input type="checkbox"/> B3 <input type="checkbox"/> B5 <input type="checkbox"/> V1 <input type="checkbox"/>		Speed at Rated Load		1770 RPM / SLIP 1.67 %		
Bearing	Type	Anti-friction		Torque (D.O.L)			
	DE/ODE	6318C3 \ 6316C3		Rated	72.6 Kg.m	100 %	
	Lubricant	GREASE(ALVANIA#2)		Starting	159.8 Kg.m	160 %	
External Thrust	Not applicable		Break down	159.8 Kg.m	220 %		
Coupling Method	<input checked="" type="checkbox"/> Direct <input type="checkbox"/> V-Belt		Allowable Load GD ² referred to motor shaft				
Shaft Extension	<input checked="" type="checkbox"/> Single <input type="checkbox"/> Double		389.000 Kg.m ²				
Terminal Box	Main	<input type="checkbox"/> Steel <input checked="" type="checkbox"/> Cast Iron		Motor GD ²			
	Aux.	<input type="checkbox"/> Yes <input checked="" type="checkbox"/> No		10.130 Kg.m ²			
	Location	<input checked="" type="checkbox"/> Left <input type="checkbox"/> Right (Viewed from Drive End)		Noise Level (dB(A))			
			88 dB(A) at 1m from motor(No-load)		Vibration(Velocity)		
			3.8 mm/sec.(peak)		Starting Duty		
			Cold 2 times \ Hot 1 time		Paint		
			Munsell No.		4.0PB5.4/5.5(VL-451)		
Application			SUBMITTAL DRAWING				
Area Classification			Not applicable				
Applicable Standard			KS				
Inspection and Performance Test			Outline Dimension Drawing \ Motor Weight(Approx.)				
HHI Stand. Maker Test Report			<input type="checkbox"/> B3 TJ8MAP51 790 Kg		<input type="checkbox"/> B5 TJ80BP51 830 Kg		
ACCESSORIES(OPTION ITEM)			<input type="checkbox"/> V1 TJ80PP51 830 Kg				
			Main T-Box Ass'y				
			3M-016882				
SPARE PARTS			REMARK				
Note: Others not mentioned in this specification shall be in accordance with HHI standard. Above technical data are only design values and shall be guaranteed with tolerance of applicable standard.			Date	DSND	CHKD	CHKD	APPD
			2004.01.27	KIM R.G.		KIM O.J.	KANG K.G.

HHI W230-131-1 * In case of Inverter or V.V.V.F Motor:Performance data is based on sine wave tests. A4(210mm X 297mm)

본 도면은 현대중공업(주) 재산이므로
허가없이 복사할 수 없음 (취급유의)

THIS DRAWING IS PROPRIETARY TO HHI. NO PART OF THIS DRAWING
MAYBE REPRODUCED WITHOUT THE PERMISSION OF HHI.

	TEFC	TYPE	(1) TNB , TDB
THREE PHASE INDUCTION MOTOR			CAST IRON FRAME

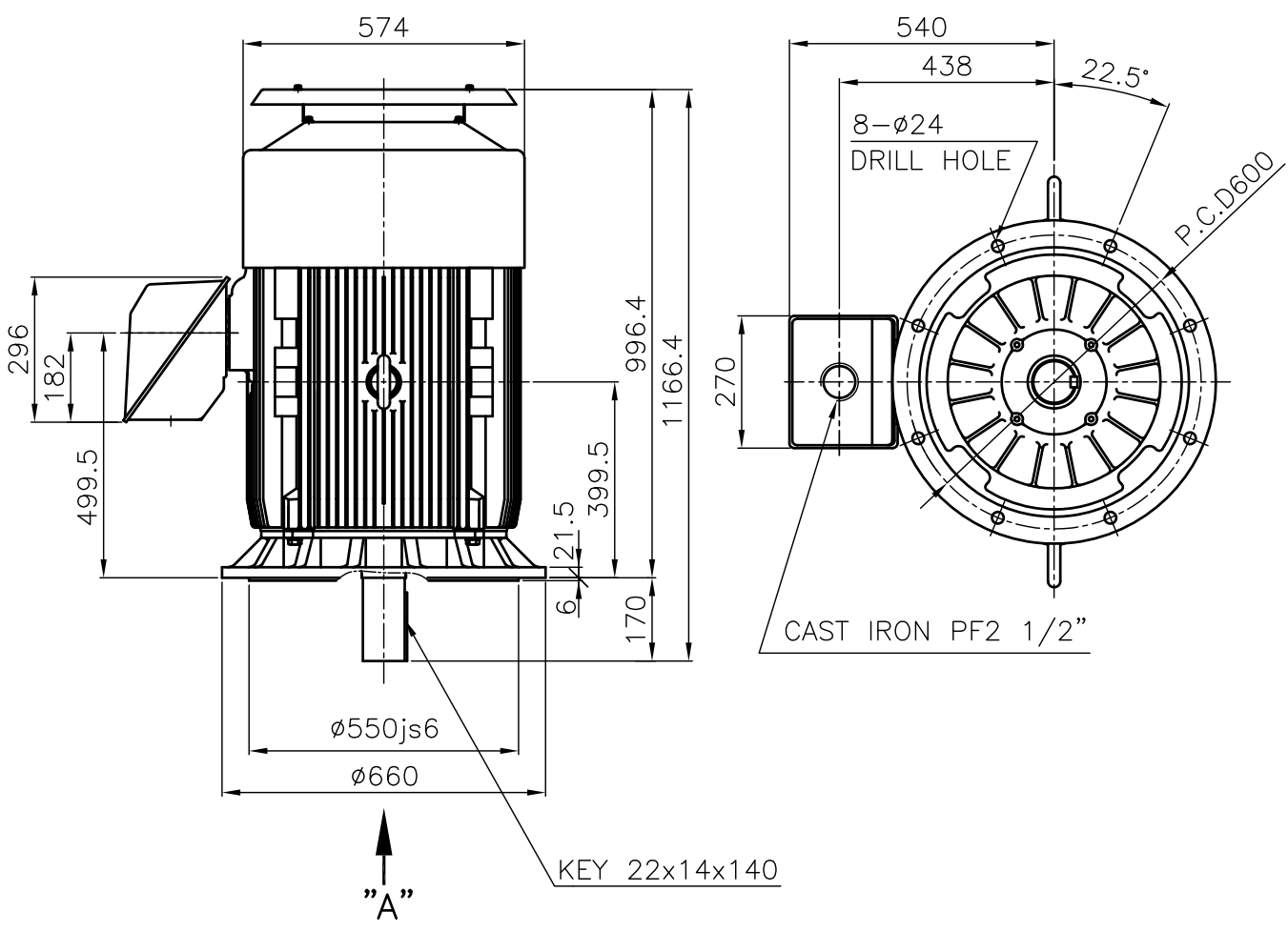

NOTE

1.TOLERANCE :

RABBET DIAMETER	ø550js6	±0.022
SHAFT DIAMETER	ø85m6	+0.035 +0.013
KEYWAY WIDTH	22P9	-0.022 -0.074
KEYWAY DEPTH	9	+0.2 0

2.The type (1)-"TNB, TDB" is for HHI's standard products and it can be changed for customer's requirements or detail designing.

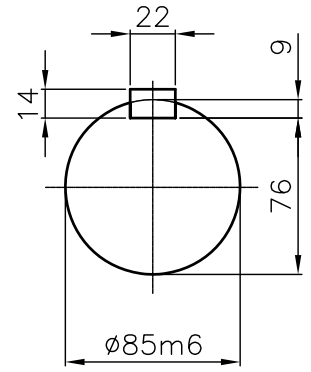

VIEW "A"
SCALE 4/1

				TEFC STANDARD		
APPD BY	KANG K.J.	UNIT	MM	SUBJECT	KS Fr.280 TEFC	CAD PROJ \ FILE
CHKD BY	KIM O.J.	SCALE	1/15			MMSTDMTR/TJ80PP51
CHKD BY	LEE N.D.	PROJEC'N	3rd Angle	TITLE	OUTLINE THREE-PHASE INDUCTION MOTOR	
DSND BY	KIM RYANG GYU	DATE	2007.03.23			
				REF. NO	L3-SERIES	Sheet No. of
				DWG NO	TJ80PP51	Revision No. 0



PERFORMANCE CURVE

CURVE NO.

P-TNBJ8M04132

TYPE :		
RATED TORQUE :	72.6	Kg.m
GD2 OF MOTOR :	10.1	Kg.m ²
(ALLOWABLE) GD2 OF LOA :	389.0	Kg.m ²

132 kW	4 P	60 Hz	
RATED SPEED :		1770 RPM	
VOLTAGE	440V	380 V	220V
RATED CURRENT	209.3A	242.3 A	418.5A

SPEED VS TORQUE & CURRENT CURVE

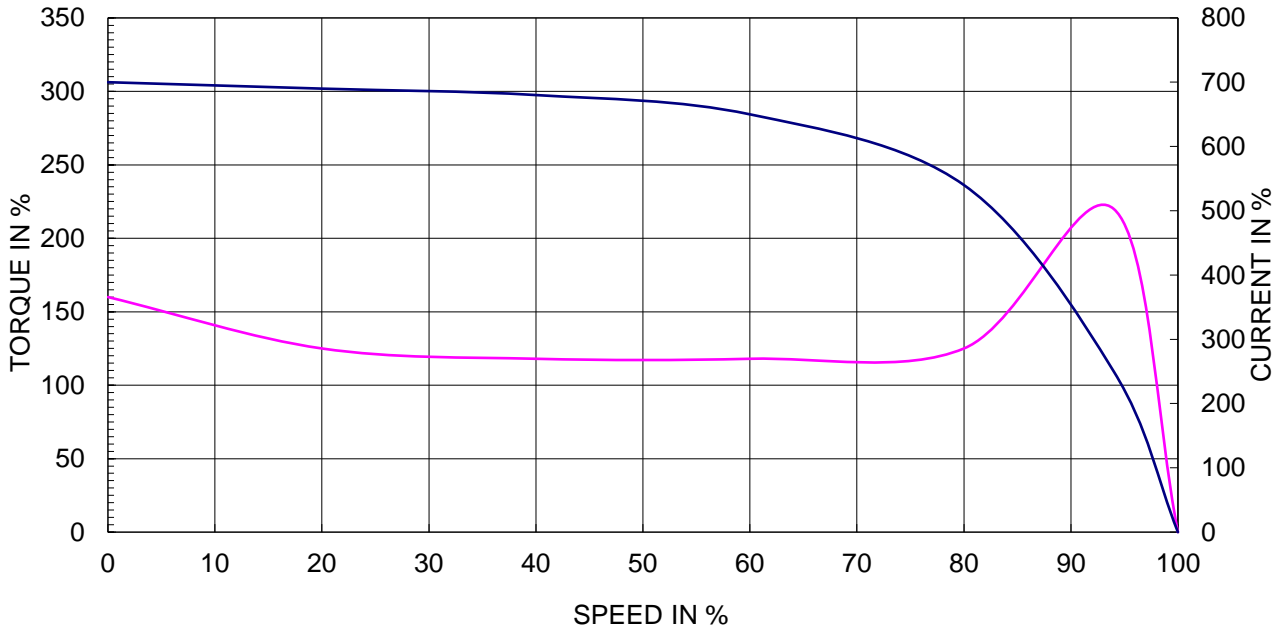

OUTPUT VS EFF., P.F & CURRENT CURVE

