



AC INDUCTION MOTOR DATA SHEET

Model No.or RFQ No.		Item No.		Rev. No. [0]			
Project Name		Project No.		Quantity sets			
GENERAL SPECIFICATION			PERFORMANCE DATA				
Frame Size	280M		Rated Output	132 kW 175 HP			
Type	HLP-132/4		Number of Poles	4			
Enclosure(Protection)	Totally Enclosed (IP55)		Rotor Type	Squirrel Cage			
Method of Cooling	IC411(FC)		Starting Method*	<input checked="" type="checkbox"/> D.O.L <input type="checkbox"/> Y- Δ			
Rated Frequency	60 Hz		Rated Voltage	440 V	380 V 220 V		
Number of Phases	3		Current	Full Load	205.5 A 237.9 A 410.9 A		
Insulation Class	<input checked="" type="checkbox"/> F <input type="checkbox"/> B <input type="checkbox"/> H		Locked-rotor**	770 % 770 % 770 %			
Temp. Rise at full load (by resistance method)			Efficiency				
at 1.0 S.F 80 deg. C			50% Load 95.0 %				
Motor Location <input checked="" type="checkbox"/> Indoor <input type="checkbox"/> Outdoor			75% Load 95.9 %				
Altitude Less than 1000 meter			100% Load 95.8 %				
Relative Humidity Less than 80 %			Power Factor(p.u)				
Ambient Temp. 40 deg. C (Max.)			50% Load 0.806				
Duty Type Continuous (S1)			75% Load 0.862				
Service Factor 1.15			100% Load 0.880				
Mounting <input type="checkbox"/> B3 <input type="checkbox"/> B5 <input type="checkbox"/> V1 <input type="checkbox"/> B3/B5			Speed at Full Load 1785 r.p.m				
Bearing	Type Anti-Friction		Torque				
	DE/N-DE 6318C3 / 6316C3		Full Load 72.0 kg·m				
	Lubricant Grease(Gadus S2 V 100 2)		Locked-rotor** 150 %				
External Thrust Not applicable			Breakdown** 230 %				
Coupling Method <input checked="" type="checkbox"/> Direct <input type="checkbox"/> V-Belt			Moment of Inertia (J)				
Shaft Extension <input checked="" type="checkbox"/> Single <input type="checkbox"/> Double			Load(Max.) 111.830 kg·m ²				
Terminal Box	Main <input type="checkbox"/> Steel <input checked="" type="checkbox"/> Cast Iron		Motor 3.415 kg·m ²				
	Aux. <input type="checkbox"/> Yes <input checked="" type="checkbox"/> No		Sound Pressure Level (No-load & mean value at 1m from motor)				
Location Refer to Outline Drawing			85 dB(A)				
Application			Vibration 2.2 mm/sec (r.m.s)				
Area classification Non-Hazardous			Permissible number of consecutive starts				
Type of Ex-Protection Not applicable			Cold 3 times				
Applicable Standard KS,IEC, NEMA MG1 Part30(Vpeak)			Hot 2 times				
			Paint Munsell No. 4.4PB5.5/5.6(VL-451)				
ACCESSORIES			SUBMITTAL DRAWING				
			Outline Dimension Drawing \ Motor Weight(Approx.)				
			B3		LM-T1283B3PL001	740 kg	
			B5		LM-T1280B5PL001	810 kg	
			V1		LM-T1280V1PL001	810 kg	
			B3/B5		LM-T1283B4PL001	775 kg	
			Main T-Box Ass'y			3M-016882	
SPARE PARTS			REMARK				
			Premium Efficiency				
			*. For use on PWM VFD 10:1VT, 3:1CT@1.0S.F&F Temp. rise				
			Date	DSND	CHKD	CHKD	APPD
			2015-09-05	R.G. KIM	-	O.J. KIM	S.H. GO

Note: Others not mentioned in this data sheet shall be in accordance with maker standard.
 Above technical data are only design values and shall be guaranteed with tolerance of applicable standard.
 Inspection and performance test shall be maker standard, if not mentioned.
 * In case of Inverter-Fed Motor, performance data is based on sine wave tests.
 ** Data is based on when the motor is supplied at rated voltage & frequency, and the data is expressed as a percentage of full-load value.

Type	:	HLP-132/4
Full Load Torque	:	72.0 Kg.m
Motor moment of Inertia (J)	:	3.415 Kg.m ²
Load moment of Inertia (J)	:	111.830 Kg.m ²

132 kW	4 P	60 Hz	
Speed at Full Load : 1785 RPM			
Rated Voltage	440V	380V	220V
Full Load Current	205.5A	237.9A	410.9A

SPEED VS TORQUE & CURRENT CURVE

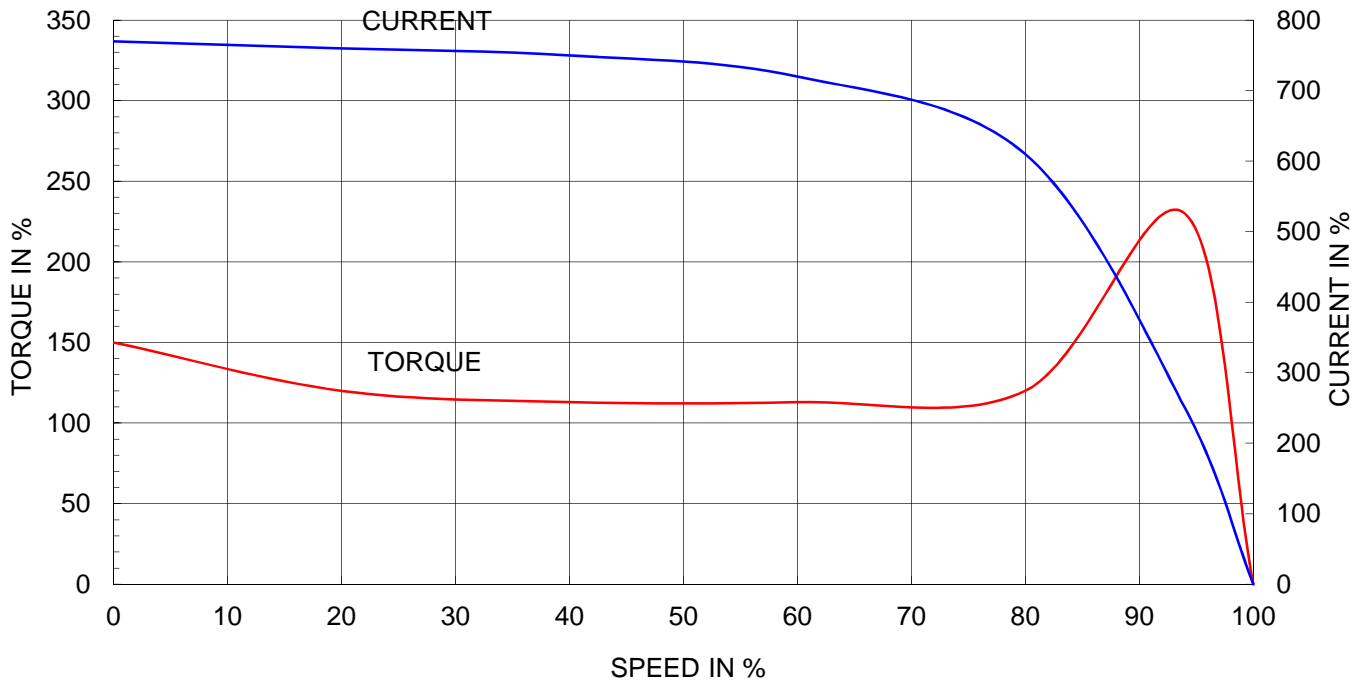

OUTPUT VS EFF., P.F & CURRENT CURVE

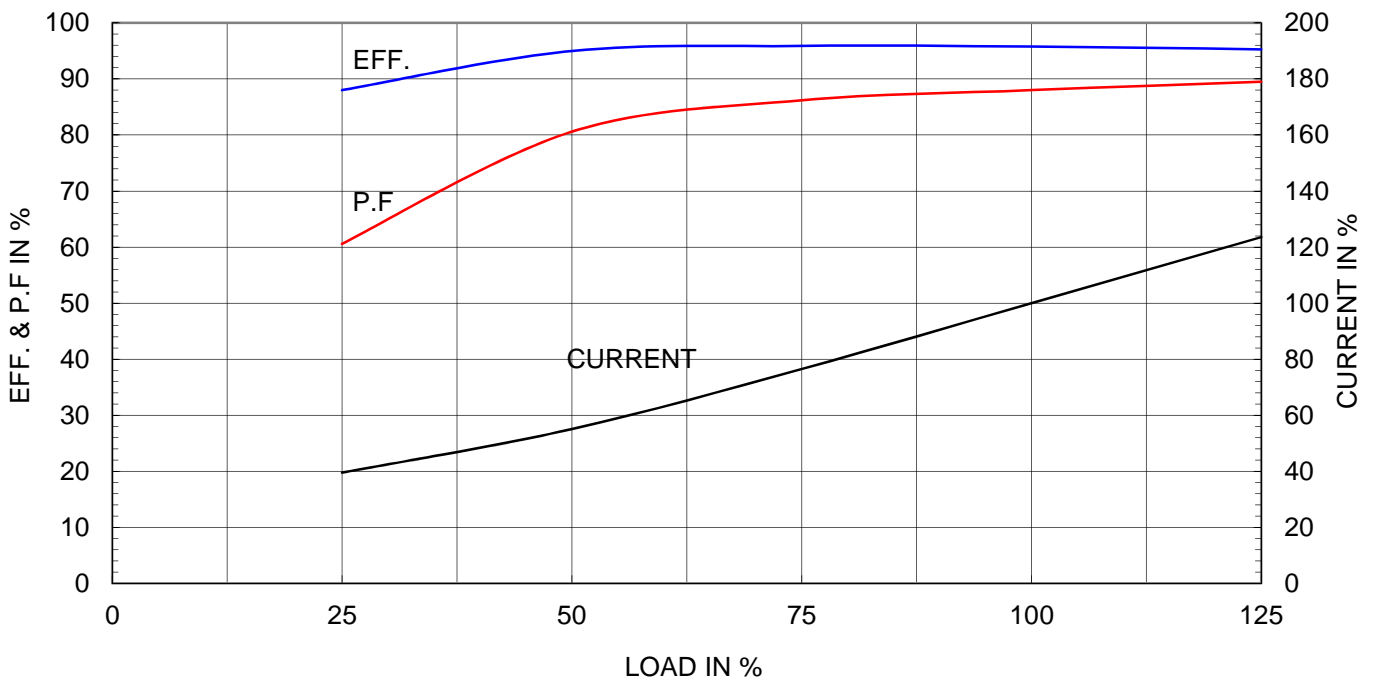

본 도면은 현대일렉트릭(주) 재산이므로
허가없이 복사할 수 없음 (취급주의)

THIS DRAWING IS PROPRIETARY TO HYUNDAI ELECTRIC. NO PART OF THIS DRAWING
MAY BE REPRODUCED WITHOUT THE PERMISSION OF HYUNDAI ELECTRIC.

	1	2	3	4				
▽	50S	REV	DATE	CONTENTS	REVD BY	CHKD BY	CHKD BY	APPD BY
▽▽	12.5S							
▽▽▽	3.2S							
▽▽▽▽	0.4S							

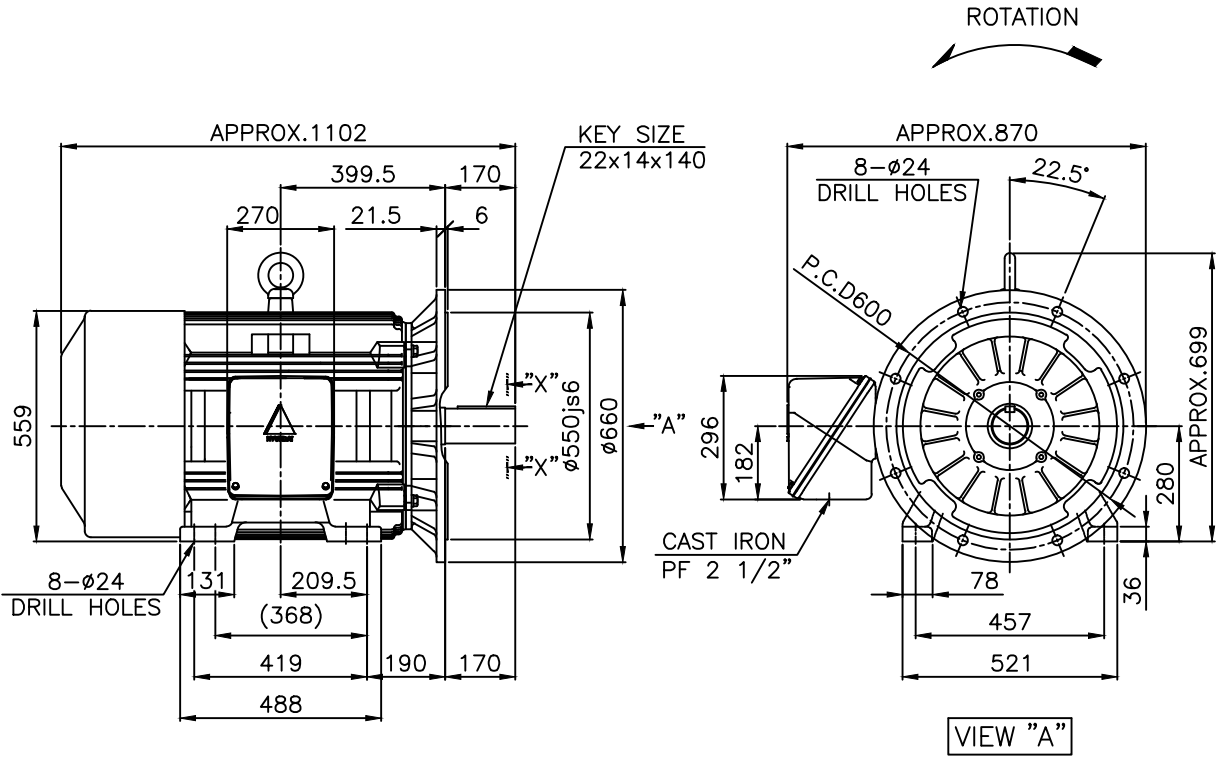

NOTE

1.TOLERANCE :

CENTER HEIGHT	280	0 -1.0
BASE HOLES	ø24	+0.52 0
FLANGE HOLES	ø24	+0.52 0
RABBET DIAMETER	ø550	±0.022
SHAFT DIAMETER	ø85	+0.035 +0.013
KEYWAY WIDTH	22	-0.022 -0.074
KEYWAY DEPTH	9	+0.2 0
KEY WIDTH	22	0 -0.052
KEY HEIGHT	14	0 -0.110

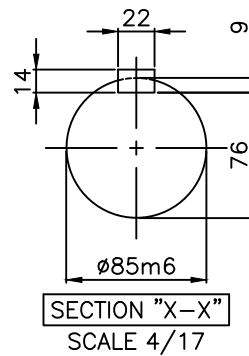

APPD BY	S.K.HAN	UNIT	mm	SUBJECT	KS, IEC Fr.280M-4*20P	DWG SIZE	A4 (1:17)
CHKD BY	S.Y.KIM	SCALE	1/17	TITLE	OUTLINE		
CHKD BY	R.G.KIM	PROJEC'N	3각법 (3rd Angle)	REF. NO		Sheet No.	of
DSND BY	S.H.YUN	DATE	2018-08-28	DWG NO	LM-T1283B4PL001	Revision No.	1

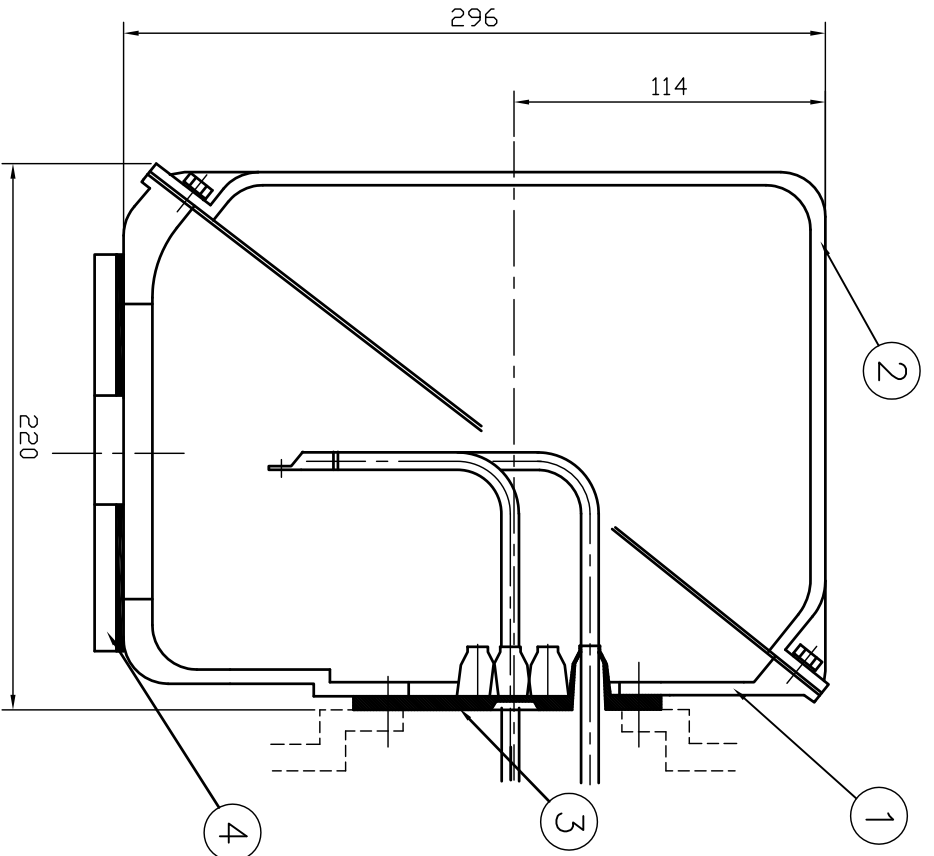
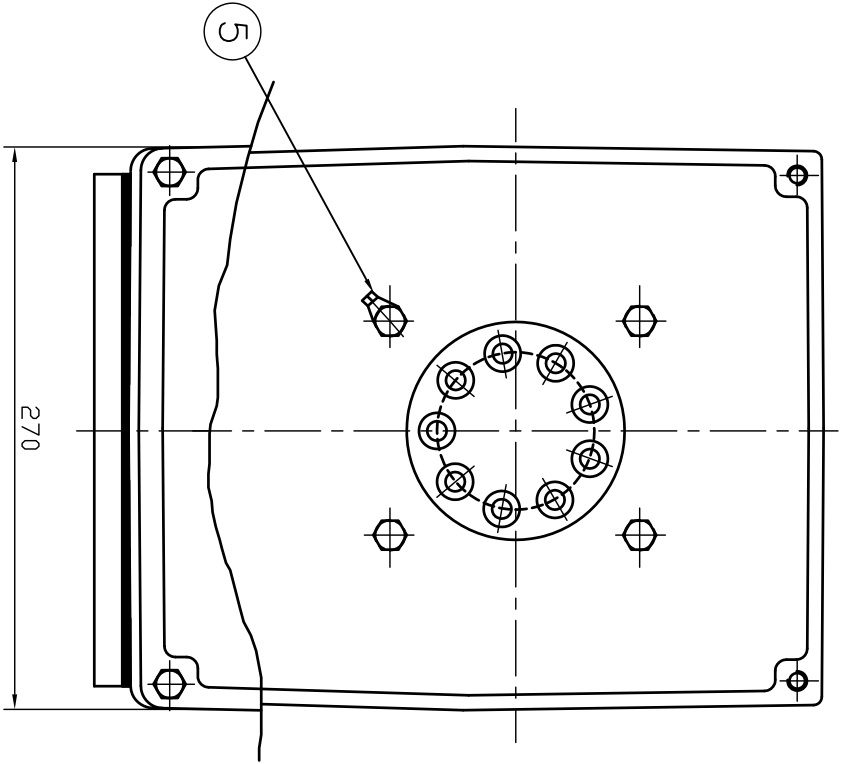

REV	DATE	CONTENTS	REV'D BY	CHK'D BY	Q.P. CHK	APP'D BY
1						

1	EARTH TERMINAL LUG																			
1	CABLE ENTRY PLATE																			
1	GASKET	NBR																		
1	TERMINAL BOX COVER	CAST IRON																		
1	TERMINAL BOX BODY	CAST IRON																		

APP'D BY	권인오	UNIT	MM	DIMENSION	WEIGHT	PART NO.	REMARK
Q.P. CHK	주영철	SCALE	NONE				
CHK'D BY	권오철	PROJEC'N	3 레벨(3rd Angle)				
DSND BY	김헌태	DATE	92.06.05				

TITLE	SUBJECT	REF. NO	DWG NO
TERMINAL BOX ASS'Y	HLA6 - 250,280Fr.		3M-016882

HYUNDAI	REF. NO	DWG NO	Revision No.
ELECTRICAL ENGINEERING CO., LTD.		3M-016882	