

Customer :  
Project Name :  
Project No. :  
Revision No. :

---

# SPECIFICATION for INDUCTION MOTOR

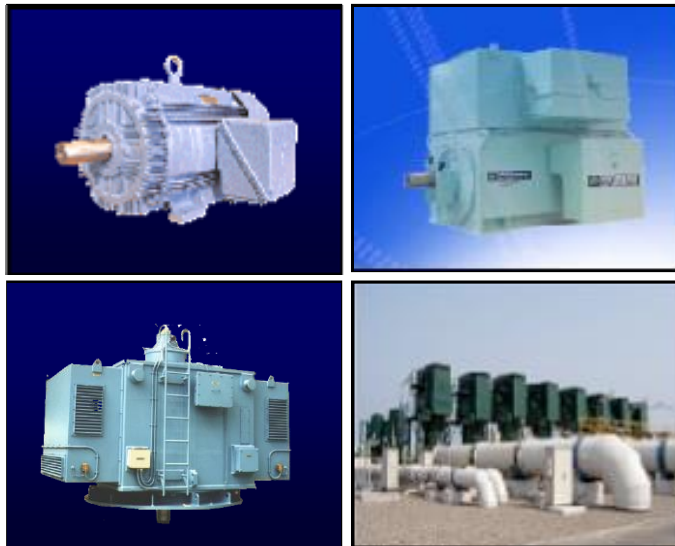

## Contents

- |                                      |           |
|--------------------------------------|-----------|
| 1 . Data Sheet of AC Induction Motor | - 1Sheets |
| 2 . Speed-Torque & Current Curve     | - 1Sheets |
| 3 . Outline Dimension Drawing        | - 1Sheets |
| 4 . Main Terminal Box Drawing        | - 1Sheets |

# AC INDUCTION MOTOR DATA SHEET

Model No.or RFQ No.	3806KSTD40SSDS1STFE3B31DL0SDS	Item No.		Rev. No.	[      ]	
Project Name		Project No.		Quantity		
GENERAL SPECIFICATION			PERFORMANCE DATA			
Frame Size	132S	Rated Output	5.5 kW	8 HP		
Type	HKP-5.5/4	Number of Poles	4			
Enclosure(Protection)	Totally Enclosed ( IP55 )	Rotor Type	Squirrel Cage			
Method of Cooling	IC411(FC)	Starting Method*	<input checked="" type="checkbox"/> D.O.L	<input type="checkbox"/> Y-Δ		
Rated Frequency	60 Hz	Rated Voltage	380 V			
Number of Phases	3	Current	Full Load	11.5 A		
Insulation Class	<input checked="" type="checkbox"/> F <input type="checkbox"/> B <input type="checkbox"/> H		Locked-rotor**	950 %		
Temp. Rise at full load (by resistance method)		Efficiency				
at 1.0 S.F	80 deg. C	50% Load		90.1 %		
Motor Location	<input checked="" type="checkbox"/> Indoor <input type="checkbox"/> Outdoor	75% Load		91.5 %		
Altitude	Less than 1000	100% Load		91.7 %		
Relative Humidity	Less than 80 %	Power Factor(p.u)				
Ambient Temp.	40 deg. C (Max.)	50% Load		0.630		
Duty Type	Continuous(S1)	75% Load		0.740		
Service Factor	1.15	100% Load		0.790		
Mounting	<input checked="" type="checkbox"/> B3 <input type="checkbox"/> B5 <input type="checkbox"/> V1 <input type="checkbox"/> B3/B5	Speed at Full Load		1760 r.p.m		
Bearing	Type	Anti-Friction				
	DE/N-DE	6208ZZC3 / 6208ZZC3				
	Lubricant	Grease(Polyrex-EM)				
External Thrust	Not applicable					
Coupling Method	<input checked="" type="checkbox"/> Direct <input type="checkbox"/> V-Belt	Torque				
Shaft Extension	<input checked="" type="checkbox"/> Single <input type="checkbox"/> Double	Full Load		3.0 kg·m		
Terminal Box	Main	<input type="checkbox"/> Steel <input checked="" type="checkbox"/> Cast Iron	Locked-rotor**		190 %	
	Aux.	<input type="checkbox"/> Yes <input checked="" type="checkbox"/> No	Breakdown**		250 %	
	Location	Refer to Outline Drawing				
Application		Moment of Inertia (J)				
Area classification	Not applicable	Load(Max.)		5.500 kg·m <sup>2</sup>		
Type of Ex-Protection	Non-Hazardous	Motor		0.024 kg·m <sup>2</sup>		
Applicable Standard	KS, IEC, NEMA MG1 Part30(Vpeak)	Sound Pressure Level (No-load & mean value at 1m from motor)				
ACCESSORIES		Vibration				1.6 mm/sec (r.m.s)
		Permissible number of consecutive starts		Cold	3 times	
				Hot	2 times	
		Paint	Munsell No.	4.4PB5.5/5.6(VL-451)		
SPARE PARTS		SUBMITTAL DRAWING				
		Outline Dimension Drawing		Motor Weight(Approx.)		
		B3	LM-T0131B3PL001	68 kg		
		Main T-Box Ass'y		3M-148549		
REMARK		*Premium Efficiency(IE3)				
		*.For use on PWM VFD 10:1VT,3:1CT@1.0S.F&F Temp.rise				
		Date	DSND	CHKD	CHKD	APPD
		2018-04-25	R.G. KIM	-	O.J. KIM	S.K. HAN

Note: Others not mentioned in this data sheet shall be in accordance with maker standard.  
 Above technical data are only design values and shall be guaranteed with tolerance of applicable standard.  
 Inspection and performance test shall be maker standard, if not mentioned.  
 \* In case of Inverter-Fed Motor, performance data is based on sine wave tests.  
 \*\* The data are based on rated voltage & frequency, and data are expressed as a percentage of full load value.

Type :	HKP-5.5/4	
Full Load Torque :	3.0	kg.m
Motor moment of Inertia (J) :	0.024	kg.m <sup>2</sup>
Load moment of Inertia (J) :	5.500	kg.m <sup>2</sup>

5.5 kW	4 P	60 Hz
Speed at Full Load :		1760 RPM
Rated Voltage	380V	
Full Load Current	11.5A	

SPEED VS TORQUE &amp; CURRENT CURVE

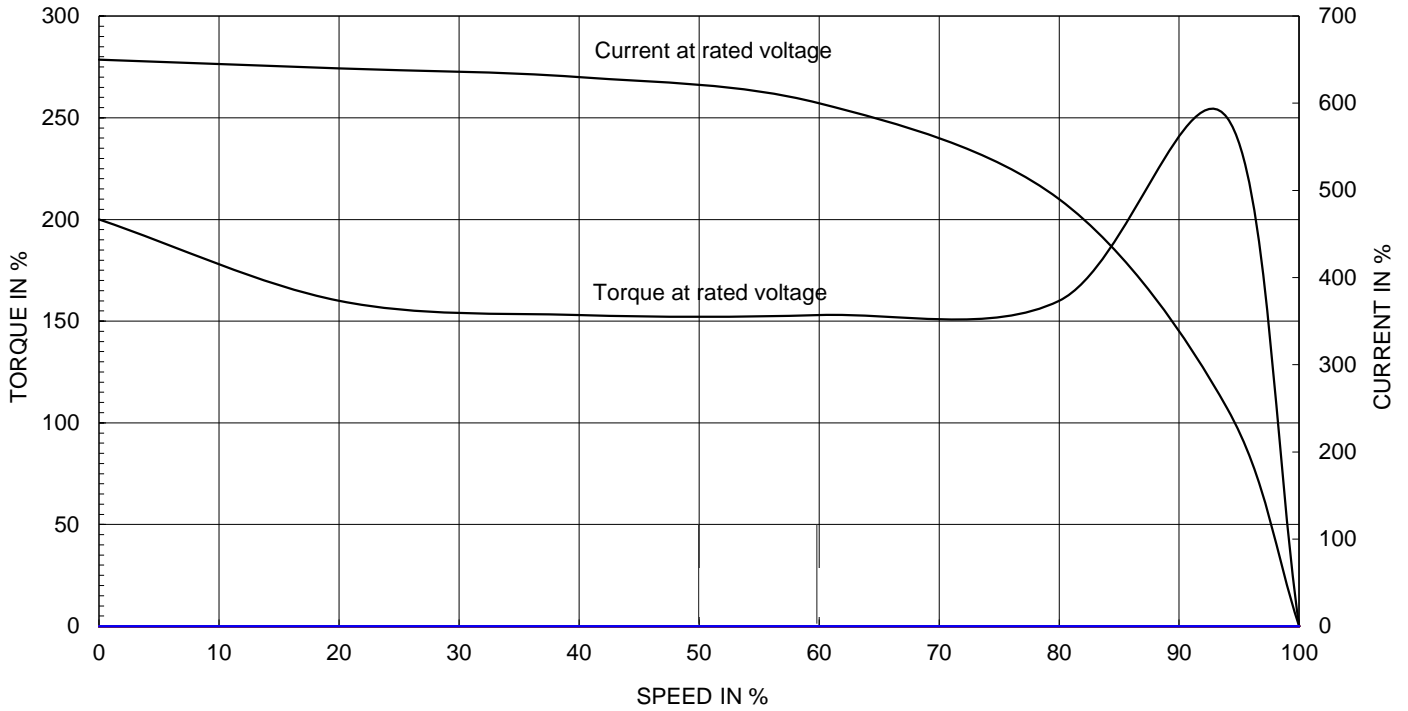

OUTPUT VS EFF., P.F &amp; CURRENT CURVE

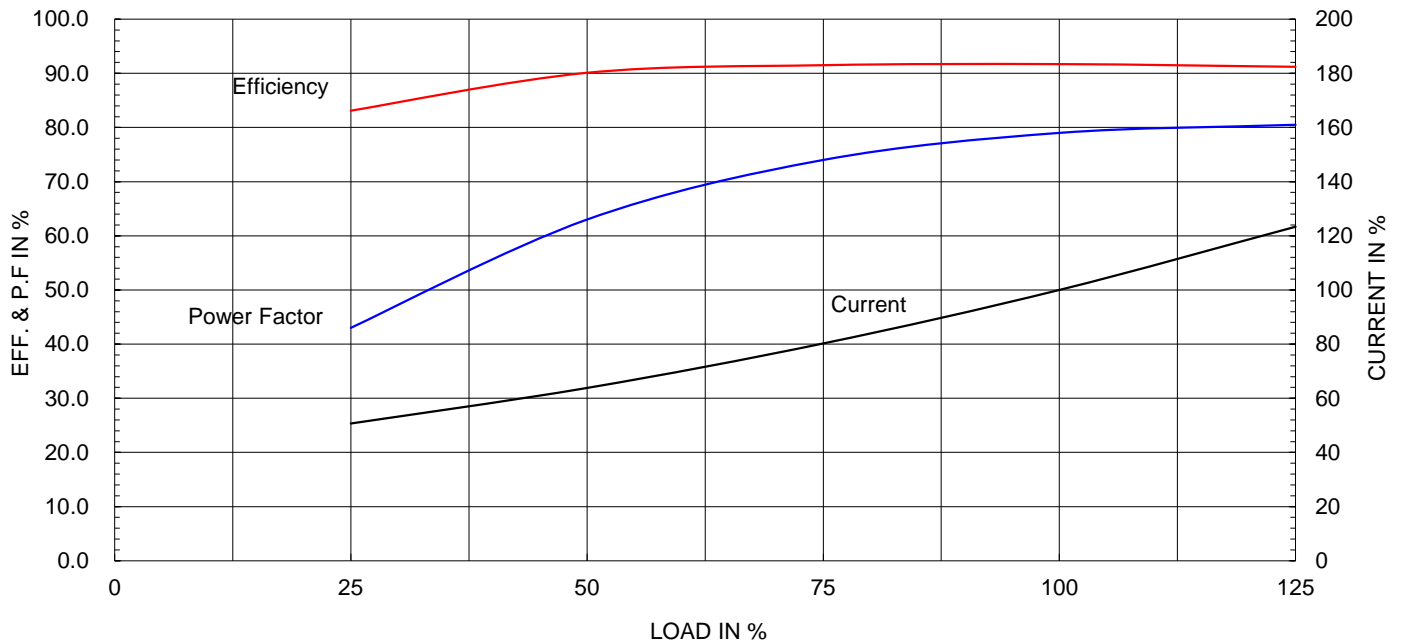

본 도면은 현대일렉트릭(주) 재산이므로  
허가없이 복사할 수 없음 (취급주의)

THIS DRAWING IS PROPRIETARY TO HYUNDAI ELECTRIC. NO PART OF THIS DRAWING  
MAY BE REPRODUCED WITHOUT THE PERMISSION OF HYUNDAI ELECTRIC.

	1	2	3	4				
▽	50S	REV	DATE	CONTENTS	REVD BY	CHKD BY	CHKD BY	APPD BY
▽▽	12.5S							
▽▽▽	3.2S							
▽▽▽▽	0.4S							

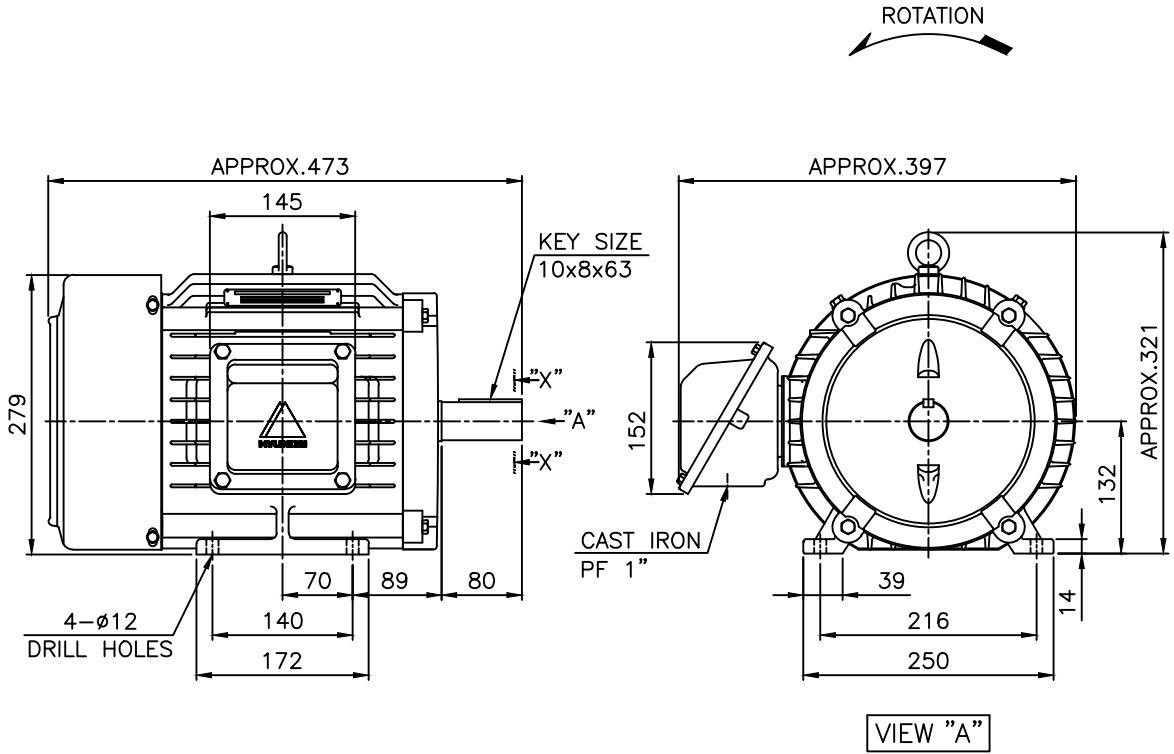

NOTE

1.TOLERANCE :

CENTER HEIGHT	132	$\begin{matrix} 0 \\ -0.5 \end{matrix}$
BASE HOLES	$\phi 12$	$\begin{matrix} +0.43 \\ 0 \end{matrix}$
SHAFT DIAMETER	$\phi 38$	$\begin{matrix} +0.018 \\ +0.002 \end{matrix}$
KEYWAY WIDTH	10	$\begin{matrix} 0 \\ -0.036 \end{matrix}$
KEYWAY DEPTH	5	$\begin{matrix} +0.2 \\ 0 \end{matrix}$
KEY WIDTH	10	$\begin{matrix} 0 \\ -0.036 \end{matrix}$
KEY HEIGHT	8	$\begin{matrix} 0 \\ -0.090 \end{matrix}$

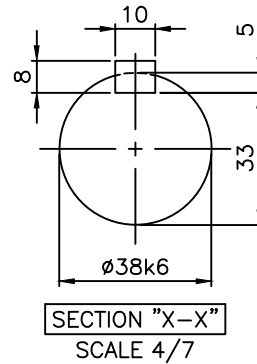

APPD BY	S.K.HAN	UNIT	mm	SUBJECT	KS, IEC Fr.132S(IE3, HK TYPE)	DWG SIZE	A4 ( 1:7 )
CHKD BY	S.Y.KIM	SCALE	1/7	TITLE OUTLINE			
CHKD BY	R.G.KIM	PROJEC'N	3각법 (3rd Angle)				
DSND BY	S.H.YUN	DATE	2018-09-18	REF. NO		Sheet No.	of
				DWG NO	LM-T0131B3PL001	Revision No.	0

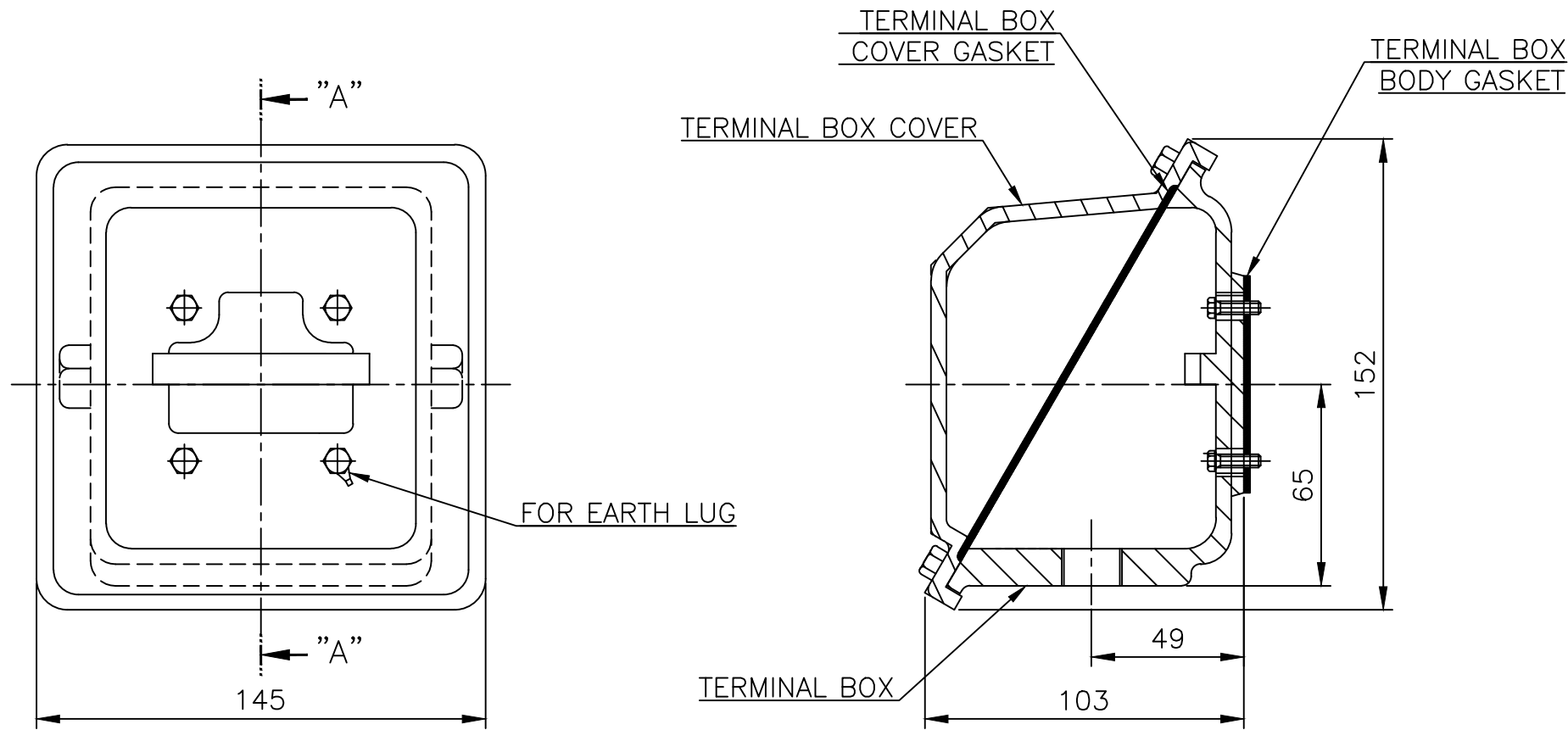

SEC. "A" - "A"

▽	50S
▽▽	12.5S
▽▽▽	3.2S
▽▽▽▽	0.4S

REV	DATE	CONTENTS	REVD BY	CHKD BY	CHKD BY	APPD BY

Q'TY	DESCRIPTION	MATERIAL	DIMENSION	WEIGHT	PART NO.	REMARK	NO.
APPD BY	S.K.HAN	UNIT	mm	SUBJECT	FR.100~132 (CAST IRON)	DWG SIZE	A3 ( 1:2 )
CHKD BY	S.Y.KIM	SCALE	1/2	TITLE			
CHKD BY	R.G.KIM	PROJEC'N	3각법 (3rd Angle)	Terminal Box Arrangement			
DSND BY	H.K.LEE	DATE	2011-10-26	REF. NO	227B8004CB	Sheet No.	of
				DWG NO	3M-148549	Revision No.	2

일반가공공차		일반재공공차	
1-4	±0.1	6-30	±0.5
4-18	±0.2	30-120	±0.8
18-63	±0.3	120-315	±1.2
63-250	±0.5	315-1000	±2.0
250-	±0.8	1000-	±3.0