

Customer :
Project Name :
Project No. :
Revision No. :

SPECIFICATION for INDUCTION MOTOR

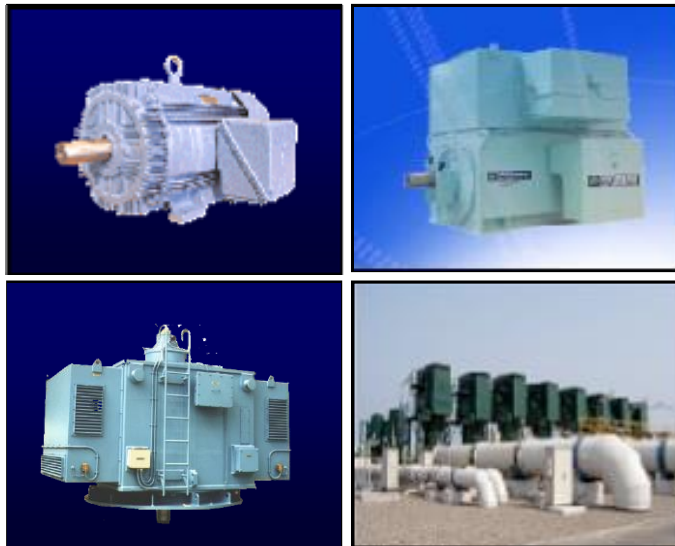

Contents

- | | |
|--------------------------------------|-----------|
| 1 . Data Sheet of AC Induction Motor | - 1Sheets |
| 2 . Speed-Torque & Current Curve | - 1Sheets |
| 3 . Outline Dimension Drawing | - 1Sheets |
| 4 . Main Terminal Box Drawing | - 1Sheets |

AC INDUCTION MOTOR DATA SHEET

Model No.or RFQ No.	4406KSTD40SSDS1STFE3351DL0SDS	Item No.		Rev. No.	[]		
Project Name		Project No.		Quantity			
GENERAL SPECIFICATION			PERFORMANCE DATA				
Frame Size	200L	Rated Output	30 kW	40 HP			
Type	HLP-30/6	Number of Poles	6				
Enclosure(Protection)	Totally Enclosed (IP55)	Rotor Type	Squirrel Cage				
Method of Cooling	IC411(FC)	Starting Method*	<input checked="" type="checkbox"/> D.O.L	<input type="checkbox"/> Y-Δ			
Rated Frequency	60 Hz	Rated Voltage	440 V				
Number of Phases	3	Current	Full Load	52.2 A			
Insulation Class	<input checked="" type="checkbox"/> F <input type="checkbox"/> B <input type="checkbox"/> H		Locked-rotor**	720 %			
Temp. Rise at full load (by resistance method)		Efficiency					
at 1.0 S.F	80 deg. C	50% Load		94.0 %			
Motor Location	<input checked="" type="checkbox"/> Indoor <input type="checkbox"/> Outdoor	75% Load		94.3 %			
Altitude	Less than 1000	100% Load		94.1 %			
Relative Humidity	Less than 80 %	Power Factor(p.u)					
Ambient Temp.	40 deg. C (Max.)	50% Load		0.660			
Duty Type	Continuous(S1)	75% Load		0.757			
Service Factor	1.15	100% Load		0.801			
Mounting	<input type="checkbox"/> B3 <input type="checkbox"/> B5 <input type="checkbox"/> V1 <input checked="" type="checkbox"/> B3/B5	Speed at Full Load	1185 r.p.m				
Bearing	Type	Anti-Friction					
	DE/N-DE	6313ZC3 / 6211ZC3					
	Lubricant	Grease(Gadus S2 V 100 2)					
External Thrust	Not applicable						
Coupling Method	<input checked="" type="checkbox"/> Direct <input type="checkbox"/> V-Belt	Moment of Inertia (J)					
Shaft Extension	<input checked="" type="checkbox"/> Single <input type="checkbox"/> Double	Load(Max.)		50.000 kg·m ²			
Terminal Box	Main	<input type="checkbox"/> Steel <input checked="" type="checkbox"/> Cast Iron	Motor		0.380 kg·m ²		
	Aux.	<input type="checkbox"/> Yes <input checked="" type="checkbox"/> No	Sound Pressure Level (No-load & mean value at 1m from motor)				
	Location	Refer to Outline Drawing					
Application		Vibration					
Area classification	Not applicable	Permissible number of consecutive starts		Cold	3 times		
Type of Ex-Protection	Non-Hazardous			Hot	2 times		
Applicable Standard	KS, IEC, NEMA MG1 Part30(Vpeak)	Paint	Munsell No.	4.4PB5.5/5.6(VL-451)			
ACCESSORIES			SUBMITTAL DRAWING				
			Outline Dimension Drawing		Motor Weight(Approx.)		
			B3/B5	LM-T1205B4PL001	327 kg		
			Main T-Box Ass'y		3M-145864		
			REMARK				
			*.Premium Efficiency(IE3)				
			*.For use on PWM VFD 10:1VT,3:1CT@1.0S.F&F Temp.rise				
SPARE PARTS			Date	DSND	CHKD	CHKD	APPD
			2018-04-25	R.G. KIM	-	O.J. KIM	S.K. HAN

Note: Others not mentioned in this data sheet shall be in accordance with maker standard.
 Above technical data are only design values and shall be guaranteed with tolerance of applicable standard.
 Inspection and performance test shall be maker standard, if not mentioned.
 * In case of Inverter-Fed Motor, performance data is based on sine wave tests.
 ** The data are based on rated voltage & frequency, and data are expressed as a percentage of full load value.

Type :	HLP-30/6	
Full Load Torque :	24.7	kg.m
Motor moment of Inertia (J) :	0.380	kg.m ²
Load moment of Inertia (J) :	50.000	kg.m ²

30 kW	6 P	60 Hz
Speed at Full Load :		1185 RPM
Rated Voltage	440V	
Full Load Current	52.2A	

SPEED VS TORQUE & CURRENT CURVE

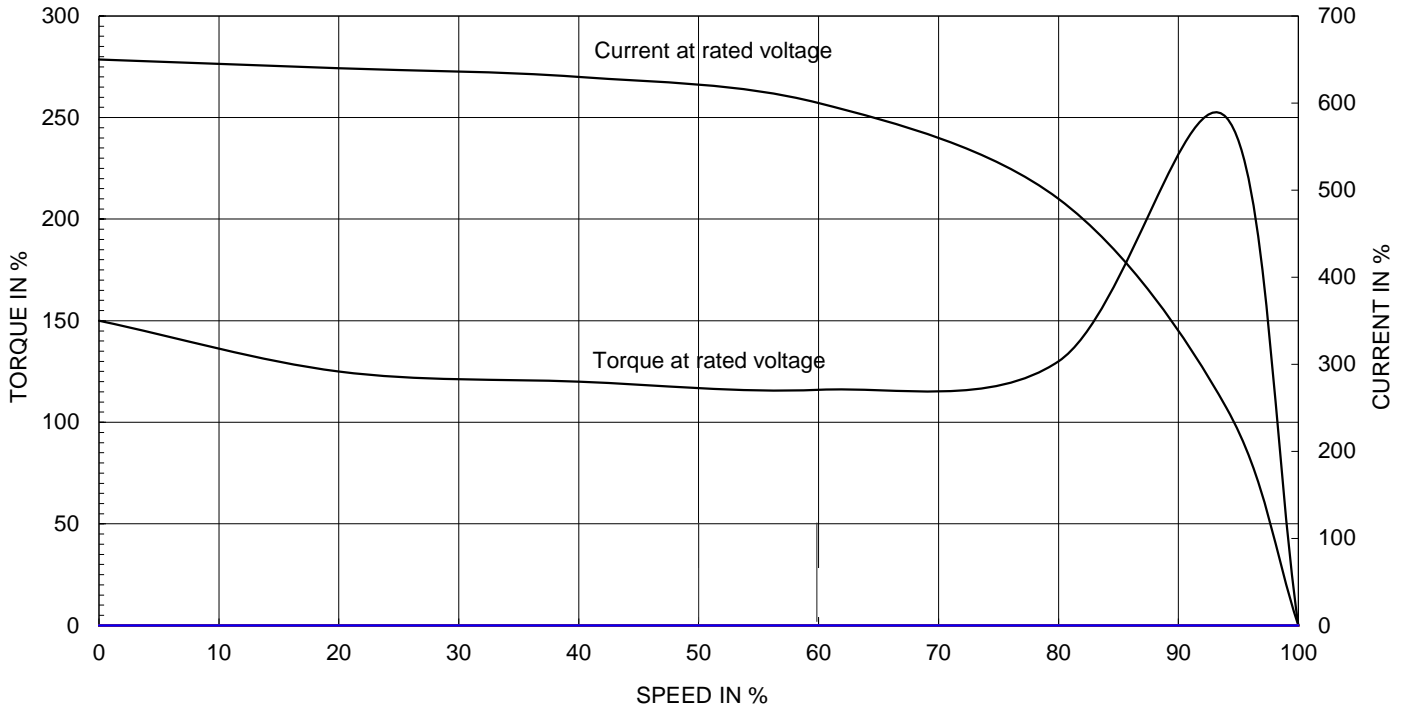

OUTPUT VS EFF., P.F & CURRENT CURVE

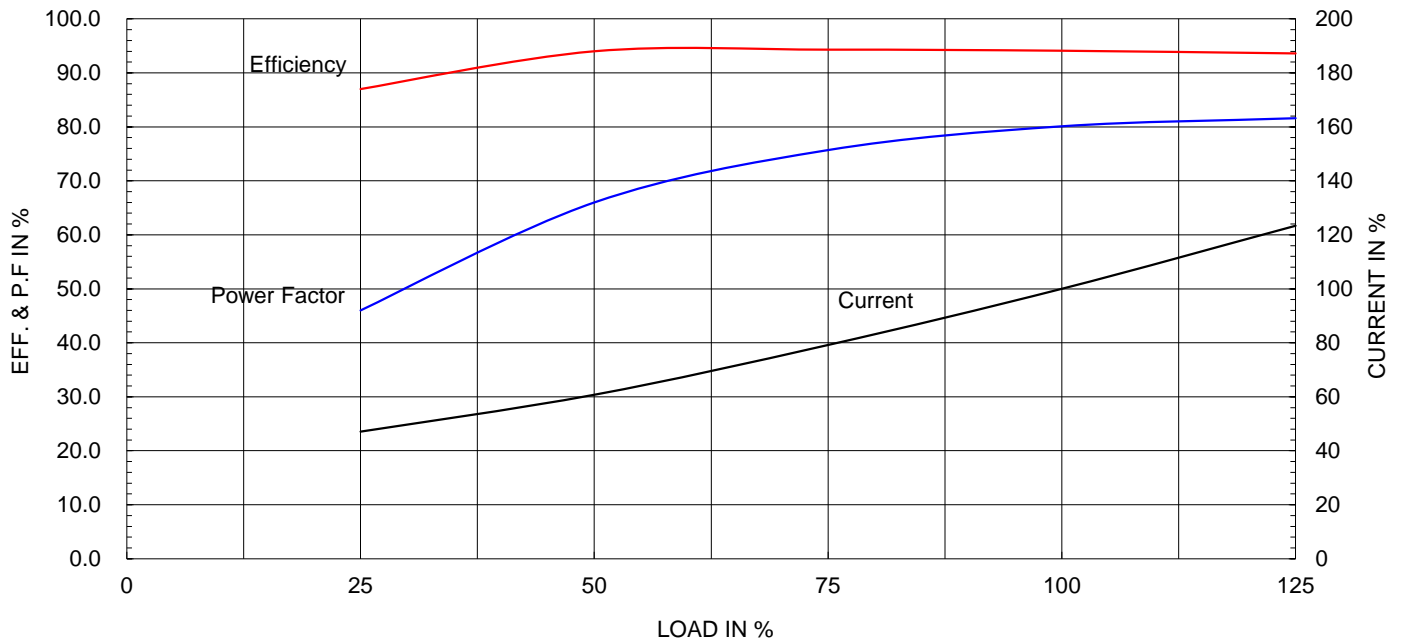

본 도면은 현대일렉트릭(주) 재산이므로
허가없이 복사할 수 없음 (취급주의)

THIS DRAWING IS PROPRIETARY TO HYUNDAI ELECTRIC. NO PART OF THIS DRAWING
MAY BE REPRODUCED WITHOUT THE PERMISSION OF HYUNDAI ELECTRIC.

	1	2	3	4				
▽	50S	REV	DATE	CONTENTS	REVD BY	CHKD BY	CHKD BY	APPD BY
▽▽	12.5S							
▽▽▽	3.2S							
▽▽▽▽	0.4S							

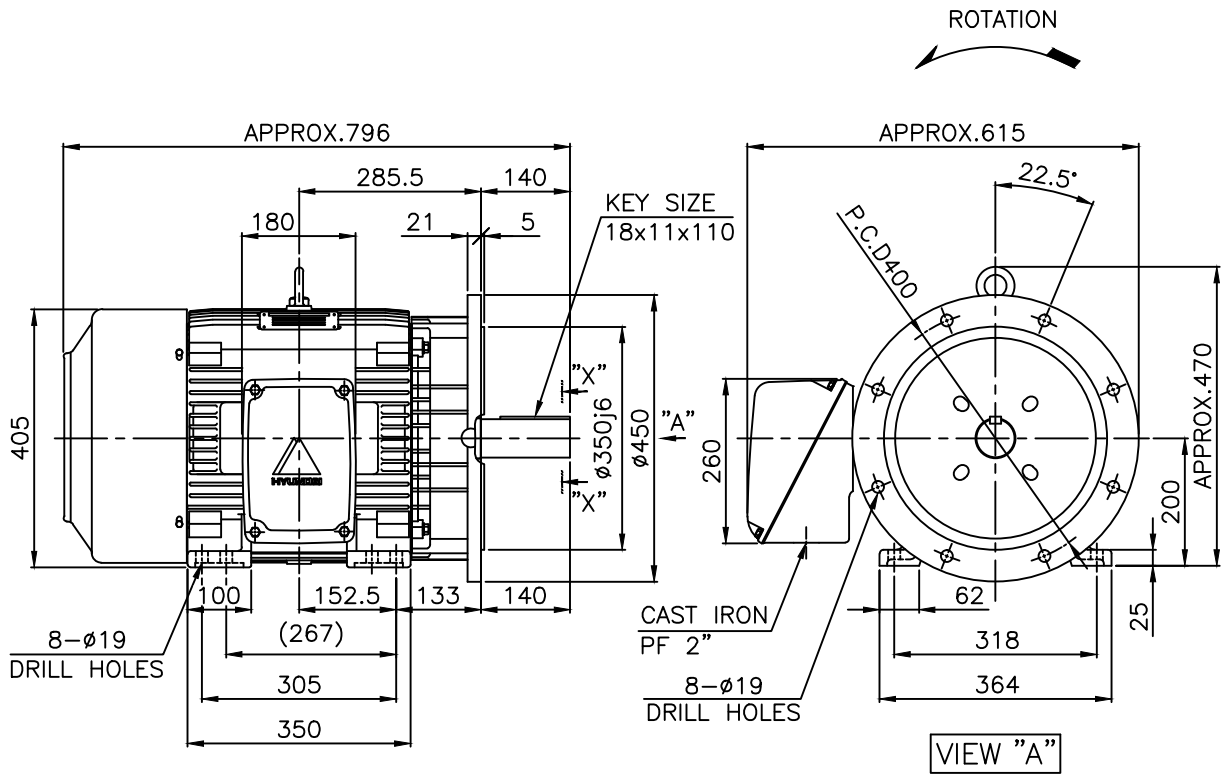

NOTE

1.TOLERANCE :

CENTER HEIGHT	200	0	-0.5
BASE HOLES	ø19	+0.52	0
FLANGE HOLES	ø19	+0.52	0
RABBET DIAMETER	ø350	±0.018	
SHAFT DIAMETER	ø60	+0.030	+0.011
KEYWAY WIDTH	18	0	-0.043
KEYWAY DEPTH	7	+0.2	0
KEY WIDTH	18	0	-0.043
KEY HEIGHT	11	0	-0.110

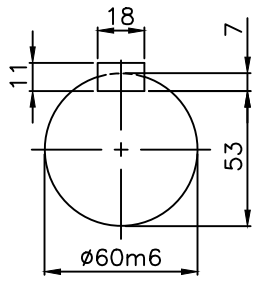

SECTION "X-X"
SCALE 4/11

APPD BY	S.K.HAN	UNIT	mm	SUBJECT	KS, IEC Fr.200L-4*20P	DWG SIZE	A4 (1:11)
CHKD BY	S.Y.KIM	SCALE	1/11	TITLE	OUTLINE		
CHKD BY	R.G.KIM	PROJEC'N	3각법 (3rd Angle)	REF. NO		Sheet No.	of
DSND BY	S.H.YUN	DATE	2018-08-14	DWG NO	LM-T1205B4PL001	Revision No.	2



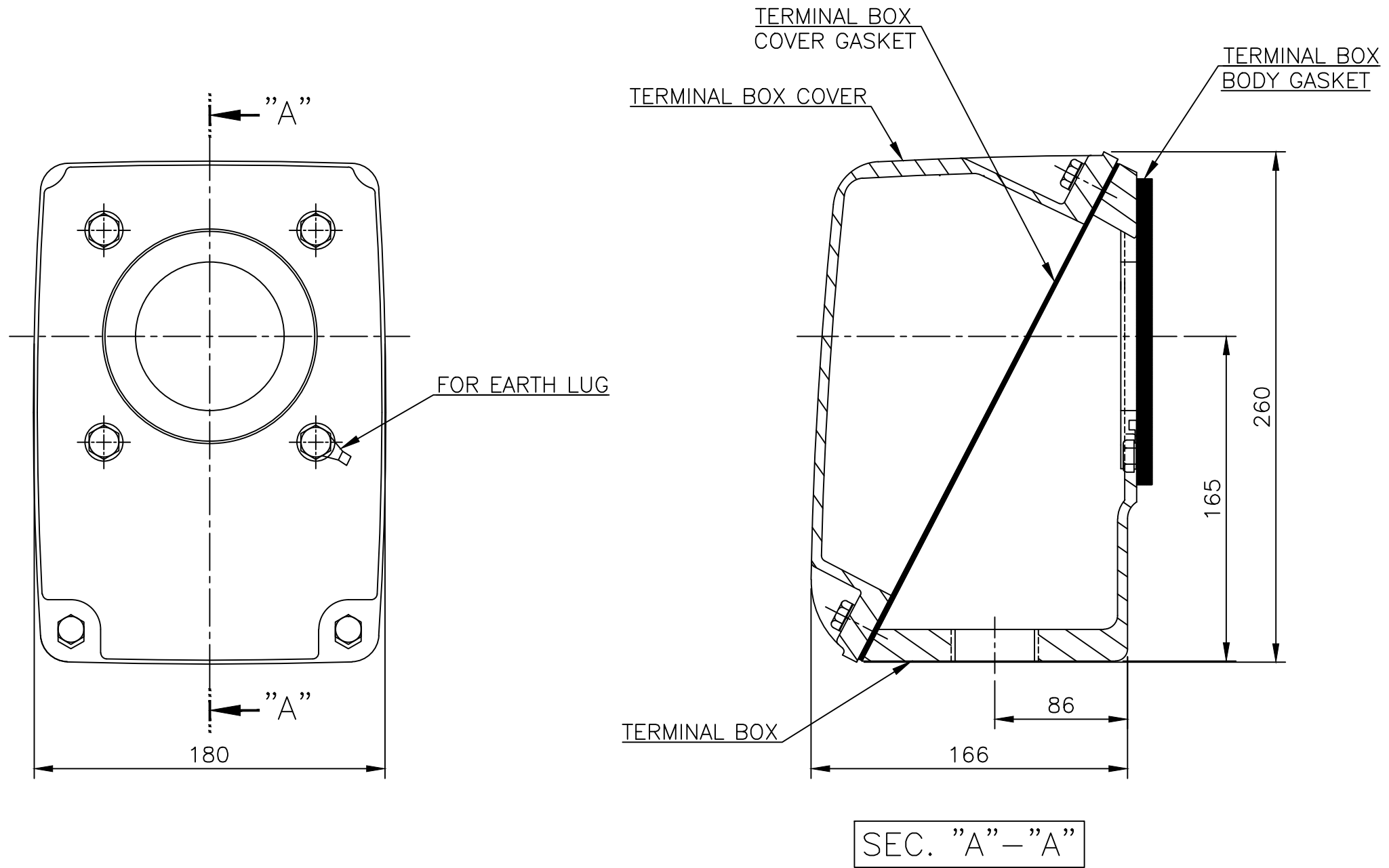

▽	50S
▽▽	12.5S
▽▽▽	3.2S
▽▽▽▽	0.4S

REV	DATE	CONTENTS	REVD BY	CHKD BY	CHKD BY	APPD BY	일반가공차		일반제관공차	
							1-4	±0.1	6-30	±0.5
							4-18	±0.2	30-120	±0.8
							18-63	±0.3	120-315	±1.2
							63-250	±0.5	315-1000	±2.0
							250-	±0.8	1000-	±3.0

Q'TY	DESCRIPTION	MATERIAL	DIMENSION	WEIGHT	PART NO.	REMARK	NO.
APPD BY	S.K.HAN	UNIT	mm	SUBJECT	FR.200 (CAST IRON)		DWG SIZE
CHKD BY	S.Y.KIM	SCALE	1/2				A3 (1:2)
CHKD BY	R.G.KIM	PROJEC'N	3각법 (3rd Angle)	TITLE			
DSND BY	H.K.LEE	DATE	2011-08-30	Main Terminal Box Assembly			
REF. NO		227B8003CB5		Sheet No.		of	
DWG NO		3M-145864		Revision No.		2	

