

Customer :
Project Name :
Project No. :
Revision No. :

SPECIFICATION for INDUCTION MOTOR



Contents

- | | |
|--------------------------------------|-----------|
| 1 . Data Sheet of AC Induction Motor | - 1Sheets |
| 2 . Speed-Torque & Current Curve | - 1Sheets |
| 3 . Outline Dimension Drawing | - 1Sheets |
| 4 . Main Terminal Box Drawing | - 1Sheets |

AC INDUCTION MOTOR DATA SHEET

Model No.or RFQ No.	4406KSTD40SSDS1STFE3B31DL0SD3	Item No.		Rev. No.	[]	
Project Name		Project No.		Quantity		
GENERAL SPECIFICATION			PERFORMANCE DATA			
Frame Size	200L	Rated Output	30 kW	40 HP		
Type	HLP-30/6	Number of Poles	6			
Enclosure(Protection)	Totally Enclosed (IP55)	Rotor Type	Squirrel Cage			
Method of Cooling	IC411(FC)	Starting Method*	<input checked="" type="checkbox"/> D.O.L	<input type="checkbox"/> Y-Δ		
Rated Frequency	60 Hz	Rated Voltage	440 V			
Number of Phases	3	Current	Full Load	52.2 A		
Insulation Class	<input checked="" type="checkbox"/> F <input type="checkbox"/> B <input type="checkbox"/> H		Locked-rotor**	720 %		
Temp. Rise at full load (by resistance method)		Efficiency				
at 1.0 S.F	80 deg. C	50% Load		94.0 %		
Motor Location	<input checked="" type="checkbox"/> Indoor <input type="checkbox"/> Outdoor	75% Load		94.3 %		
Altitude	Less than 1000	100% Load		94.1 %		
Relative Humidity	Less than 80 %	Power Factor(p.u)				
Ambient Temp.	40 deg. C (Max.)	50% Load		0.660		
Duty Type	Continuous(S1)	75% Load		0.757		
Service Factor	1.15	100% Load		0.801		
Mounting	<input checked="" type="checkbox"/> B3 <input type="checkbox"/> B5 <input type="checkbox"/> V1 <input type="checkbox"/> B3/B5	Speed at Full Load	1185 r.p.m			
Bearing	Type	Anti-Friction				
	DE/N-DE	6313ZC3 / 6211ZC3				
	Lubricant	Grease(Gadus S2 V 100 2)				
External Thrust	Not applicable					
Coupling Method	<input checked="" type="checkbox"/> Direct <input type="checkbox"/> V-Belt	Torque				
Shaft Extension	<input checked="" type="checkbox"/> Single <input type="checkbox"/> Double	Full Load		24.7 kg·m		
Terminal Box	Main	<input type="checkbox"/> Steel <input checked="" type="checkbox"/> Cast Iron	Locked-rotor**		150 %	
	Aux.	<input type="checkbox"/> Yes <input checked="" type="checkbox"/> No	Breakdown**		220 %	
	Location	Refer to Outline Drawing				
Application		Moment of Inertia (J)				
Area classification	Not applicable	Load(Max.)		50.000 kg·m ²		
Type of Ex-Protection	Non-Hazardous	Motor		0.380 kg·m ²		
Applicable Standard	KS, IEC, NEMA MG1 Part30(Vpeak)	Sound Pressure Level (No-load & mean value at 1m from motor)				
ACCESSORIES		Vibration				2.2 mm/sec (r.m.s)
		Permissible number of consecutive starts		Cold	3 times	
				Hot	2 times	
		Paint	Munsell No.	4.4PB5.5/5.6(VL-451)		
		SUBMITTAL DRAWING				
		Outline Dimension Drawing		Motor Weight(Approx.)		
		B3	LM-T1205B3PL001	297 kg		
		Main T-Box Ass'y		3M-145864		
		REMARK				
		*.Premium Efficiency(IE3)				
		*.For use on PWM VFD 10:1VT,3:1CT@1.0S.F&F Temp.rise				
SPARE PARTS		Date	DSND	CHKD	CHKD	
		2018-04-25	R.G. KIM	-	O.J. KIM	
					APPD	
					S.K. HAN	

Note: Others not mentioned in this data sheet shall be in accordance with maker standard.
 Above technical data are only design values and shall be guaranteed with tolerance of applicable standard.
 Inspection and performance test shall be maker standard, if not mentioned.
 * In case of Inverter-Fed Motor, performance data is based on sine wave tests.
 ** The data are based on rated voltage & frequency, and data are expressed as a percentage of full load value.

Type :	HLP-30/6	
Full Load Torque :	24.7	kg.m
Motor moment of Inertia (J) :	0.380	kg.m ²
Load moment of Inertia (J) :	50.000	kg.m ²

30 kW	6 P	60 Hz
Speed at Full Load :		1185 RPM
Rated Voltage	440V	
Full Load Current	52.2A	

SPEED VS TORQUE & CURRENT CURVE



OUTPUT VS EFF., P.F & CURRENT CURVE

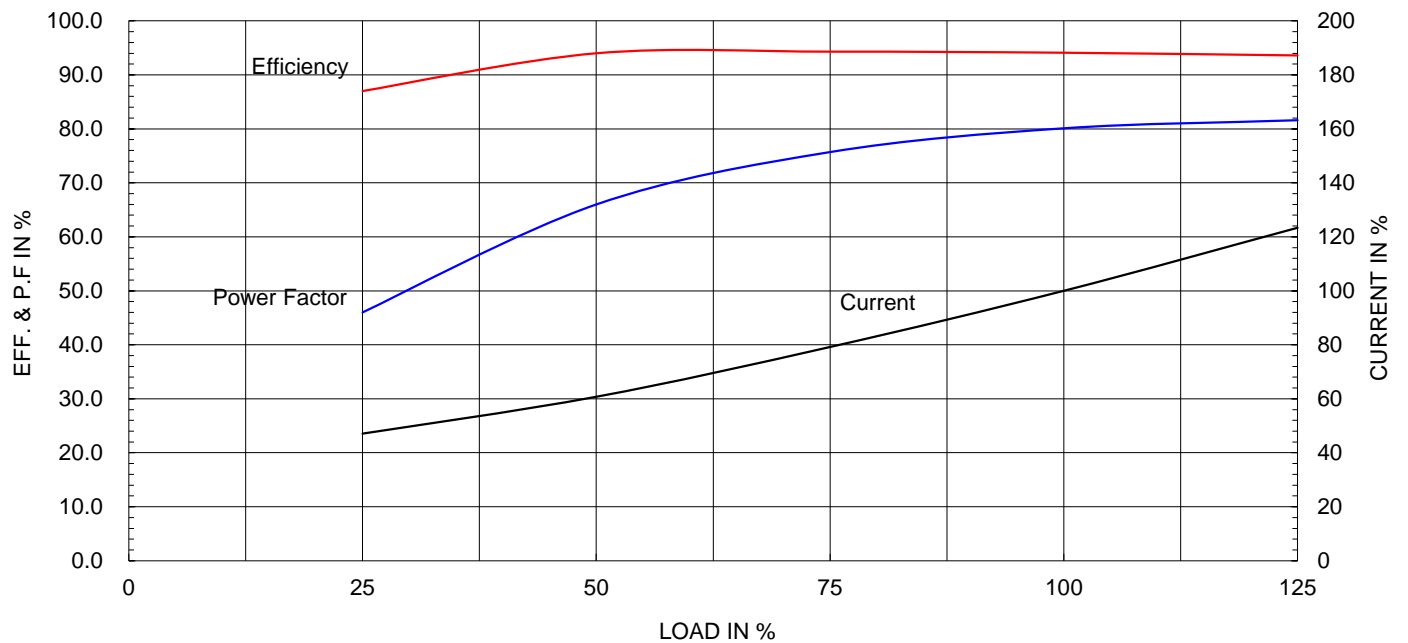

본 도면은 현대일렉트릭(주) 재산이므로
허가없이 복사할 수 없음 (취급주의)

THIS DRAWING IS PROPRIETARY TO HYUNDAI ELECTRIC. NO PART OF THIS DRAWING
MAY BE REPRODUCED WITHOUT THE PERMISSION OF HYUNDAI ELECTRIC.

	1	2	3	4				
▽	50S	REV	DATE	CONTENTS	REVD BY	CHKD BY	CHKD BY	APPD BY
▽▽	12.5S							
▽▽▽	3.2S							
▽▽▽▽	0.4S							

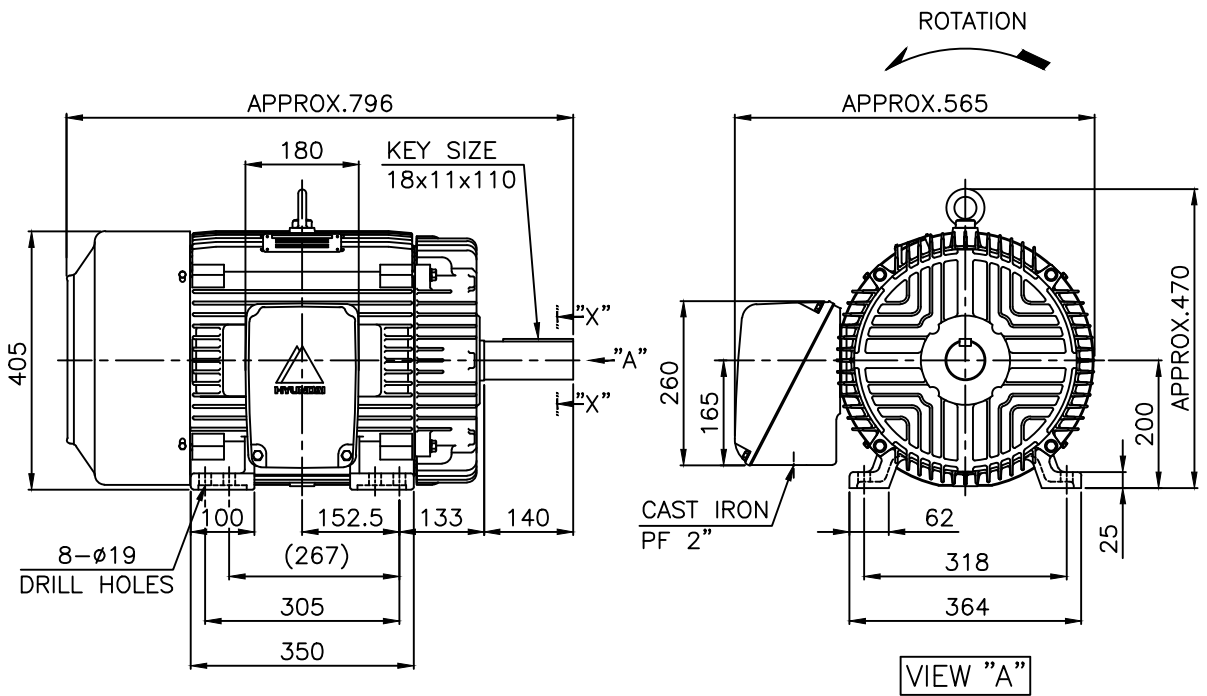

NOTE

1. TOLERANCE :

CENTER HEIGHT	200	$\begin{matrix} 0 \\ -0.5 \end{matrix}$
BASE HOLES	$\phi 19$	$\begin{matrix} +0.52 \\ 0 \end{matrix}$
SHAFT DIAMETER	$\phi 60$	$\begin{matrix} +0.030 \\ +0.011 \end{matrix}$
KEYWAY WIDTH	18	$\begin{matrix} 0 \\ -0.043 \end{matrix}$
KEYWAY DEPTH	7	$\begin{matrix} +0.2 \\ 0 \end{matrix}$
KEY WIDTH	18	$\begin{matrix} 0 \\ -0.043 \end{matrix}$
KEY HEIGHT	11	$\begin{matrix} 0 \\ -0.110 \end{matrix}$

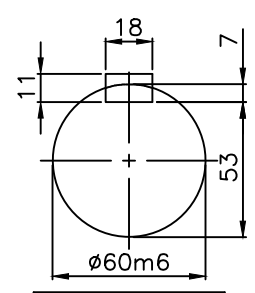

SECTION "X-X"
SCALE 4/11

APPD BY	S.K.HAN	UNIT	mm	SUBJECT	KS, IEC Fr.200L-4*20P	DWG SIZE	A4 (1:1)
CHKD BY	S.Y.KIM	SCALE	1/11	TITLE	OUTLINE		
CHKD BY	R.G.KIM	PROJEC'N	3각법(3rd Angle)	REF. NO		Sheet No.	of
DSND BY	S.H.YUN	DATE	2011-10-22	DWG NO	LM-T1205B3PL001	Revision No.	2



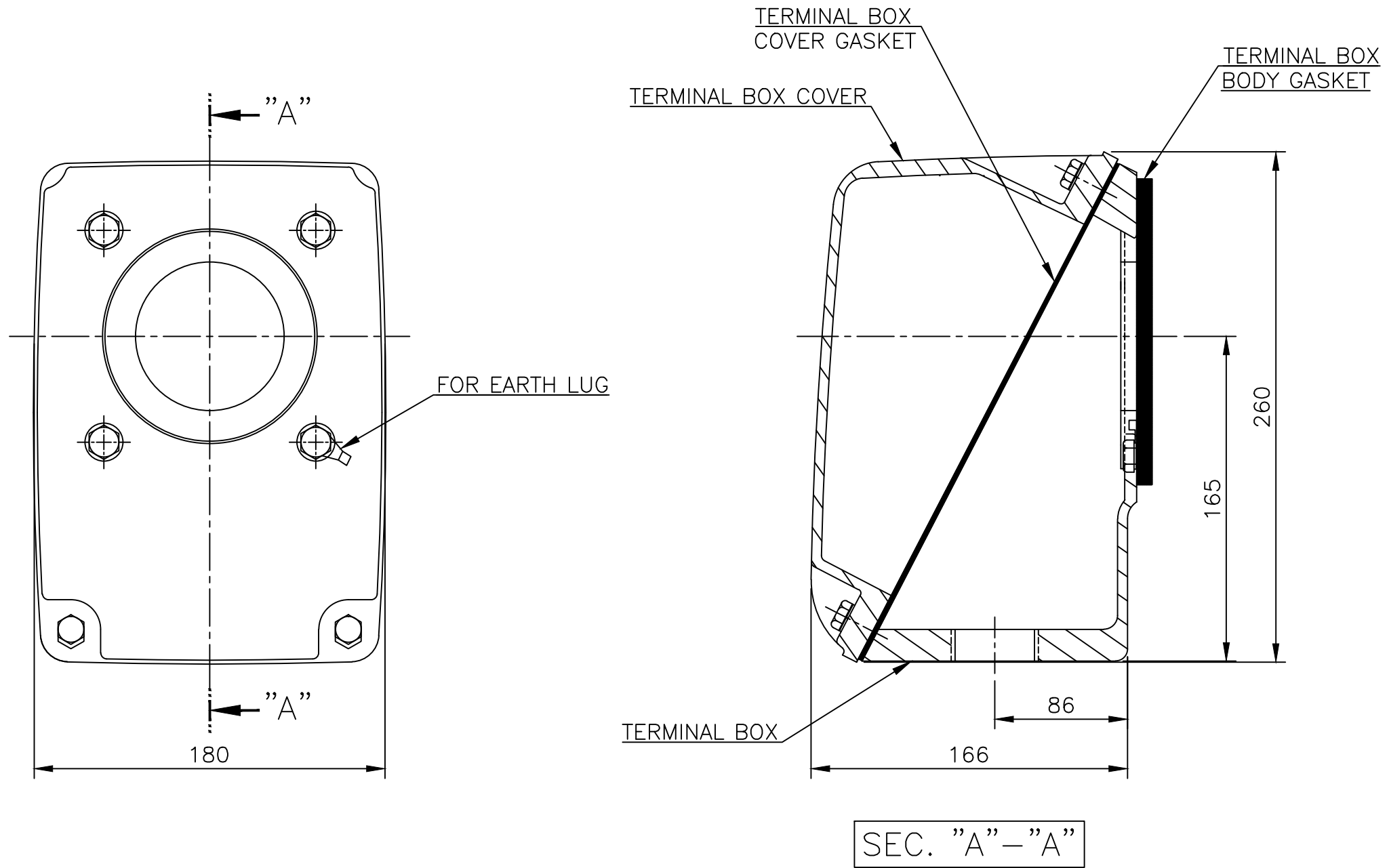

▽	50S
▽▽	12.5S
▽▽▽	3.2S
▽▽▽▽	0.4S

REV	DATE	CONTENTS	REVD BY	CHKD BY	CHKD BY	APPD BY

일반가공차		일반제관공차	
1-4	±0.1	6-30	±0.5
4-18	±0.2	30-120	±0.8
18-63	±0.3	120-315	±1.2
63-250	±0.5	315-1000	±2.0
250-	±0.8	1000-	±3.0

Q'TY	DESCRIPTION	MATERIAL	DIMENSION	WEIGHT	PART NO.	REMARK	NO.
APPD BY	S.K.HAN	UNIT	mm	SUBJECT	FR.200 (CAST IRON)	DWG SIZE	A3 (1:2)
CHKD BY	S.Y.KIM	SCALE	1/2	TITLE Main Terminal Box Assembly			
CHKD BY	R.G.KIM	PROJEC'N	3각법(3rd Angle)				
DSND BY	H.K.LEE	DATE	2011-08-30	REF. NO.	227B8003CB5	Sheet No.	of
				DWG NO.	3M-145864	Revision No.	2