

Customer :
Project Name :
Project No. :
Revision No. :

SPECIFICATION for INDUCTION MOTOR

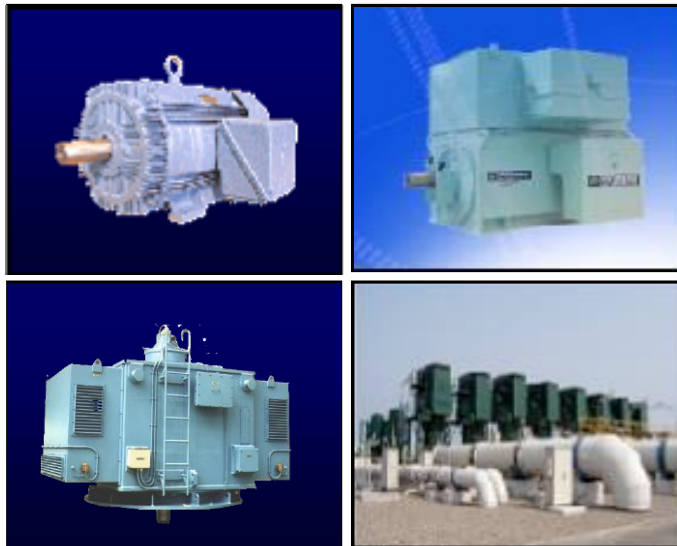

Contents

- | | |
|--------------------------------------|-----------|
| 1 . Data Sheet of AC Induction Motor | - 1Sheets |
| 2 . Speed-Torque & Current Curve | - 1Sheets |
| 3 . Outline Dimension Drawing | - 1Sheets |
| 4 . Main Terminal Box Drawing | - 1Sheets |

AC INDUCTION MOTOR DATA SHEET

Model No.or RFQ No.	3806KSTD40SSDS1STFE3B51DL0SDS	Item No.		Rev. No.	[]	
Project Name		Project No.		Quantity		
GENERAL SPECIFICATION			PERFORMANCE DATA			
Frame Size	90L	Rated Output	2.2 kW	3 HP		
Type	HLP-2.2/2	Number of Poles	2			
Enclosure(Protection)	Totally Enclosed (IP55)	Rotor Type	Squirrel Cage			
Method of Cooling	IC411(FC)	Starting Method*	<input checked="" type="checkbox"/> D.O.L	<input type="checkbox"/> Y-Δ		
Rated Frequency	60 Hz	Rated Voltage	380 V			
Number of Phases	3	Current	Full Load	4.5 A		
Insulation Class	<input checked="" type="checkbox"/> F <input type="checkbox"/> B <input type="checkbox"/> H		Locked-rotor**	1000 %		
Temp. Rise at full load (by resistance method)		Efficiency				
at 1.0 S.F	80 deg. C					
Motor Location	<input checked="" type="checkbox"/> Indoor <input type="checkbox"/> Outdoor					
Altitude	Less than 1000	100% Load		86.5 %		
Relative Humidity	Less than 80 %	Power Factor(p.u)				
Ambient Temp.	40 deg. C (Max.)					
Duty Type	Continuous(S1)					
Service Factor	1.15	100% Load		0.858		
Mounting	<input type="checkbox"/> B3 <input checked="" type="checkbox"/> B5 <input type="checkbox"/> V1 <input type="checkbox"/> B3/B5	Speed at Full Load	3500 r.p.m			
Bearing	Type	Anti-Friction				
	DE/N-DE	6205ZZ / 6204ZZ				
	Lubricant	Grease(HIFLEX L-3)				
External Thrust	Not applicable					
Coupling Method	<input checked="" type="checkbox"/> Direct <input type="checkbox"/> V-Belt	Moment of Inertia (J)				
Shaft Extension	<input checked="" type="checkbox"/> Single <input type="checkbox"/> Double					
Terminal Box	Main					<input type="checkbox"/> Steel <input checked="" type="checkbox"/> Cast Iron
	Aux.	<input type="checkbox"/> Yes <input checked="" type="checkbox"/> No				
	Location	Refer to Outline Drawing				
Application		Sound Pressure Level (No-load & mean value at 1m from motor)				
Area classification	Not applicable					
Type of Ex-Protection	Non-Hazardous					
Applicable Standard	KS, IEC, NEMA MG1 Part30(Vpeak)	73 dB(A)				
ACCESSORIES		SUBMITTAL DRAWING				
		Outline Dimension Drawing		Motor Weight(Approx.)		
		B5	LM-A1095B5P1001	21 kg		
		Main T-Box Ass'y		3M-148548		
REMARK						
*.Premium Efficiency(IE3) *.For use on PWM VFD 10:1VT,3:1CT@1.0S.F&F Temp.rise						
SPARE PARTS						
		Date	DSND	CHKD	CHKD	APPD
		2018-04-25	R.G. KIM	-	O.J. KIM	S.K. HAN

Note: Others not mentioned in this data sheet shall be in accordance with maker standard.
 Above technical data are only design values and shall be guaranteed with tolerance of applicable standard.
 Inspection and performance test shall be maker standard, if not mentioned.
 * In case of Inverter-Fed Motor, performance data is based on sine wave tests.
 ** The data are based on rated voltage & frequency, and data are expressed as a percentage of full load value.

Type :	HLP-2.2/2	
Full Load Torque :	0.6	kg.m
Motor moment of Inertia (J) :	0.002	kg.m ²
Load moment of Inertia (J) :	0.325	kg.m ²

2.2 kW	2 P	60 Hz
Speed at Full Load :		3500 RPM
Rated Voltage	380V	
Full Load Current	4.5A	

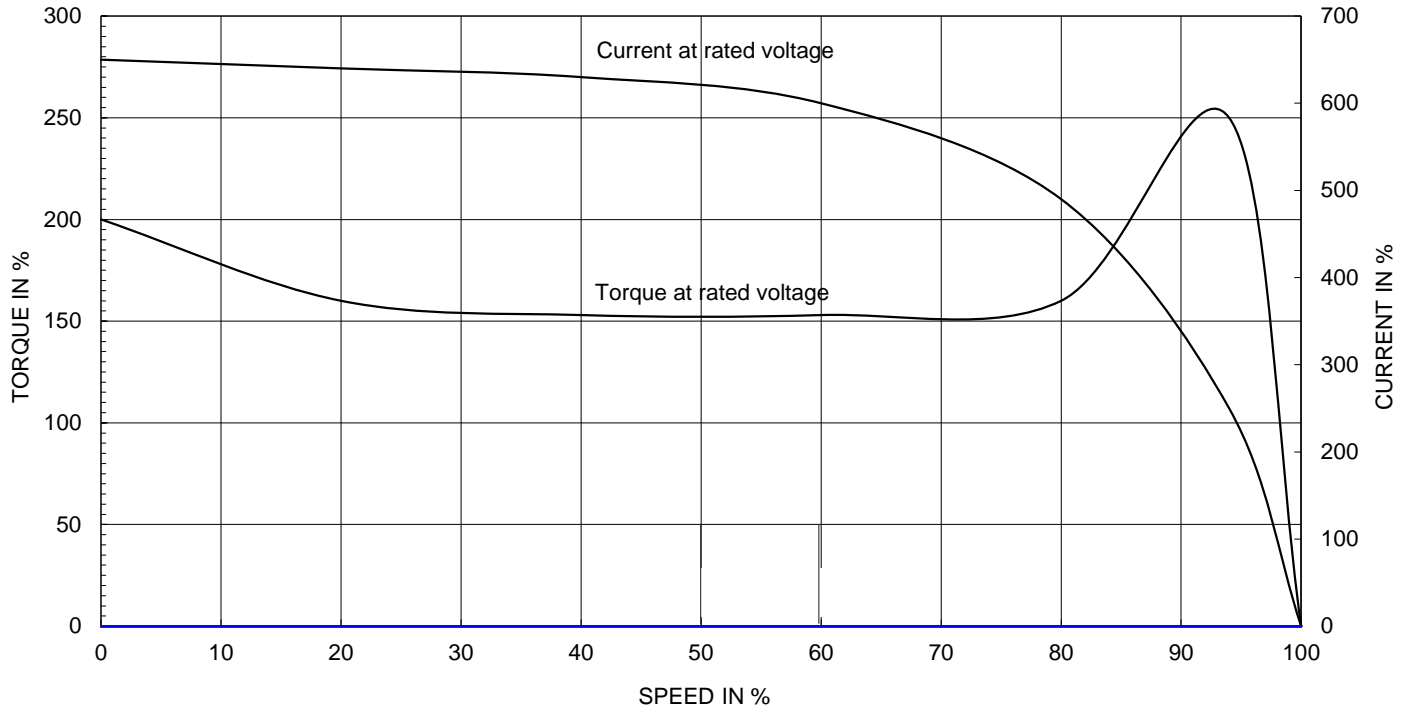
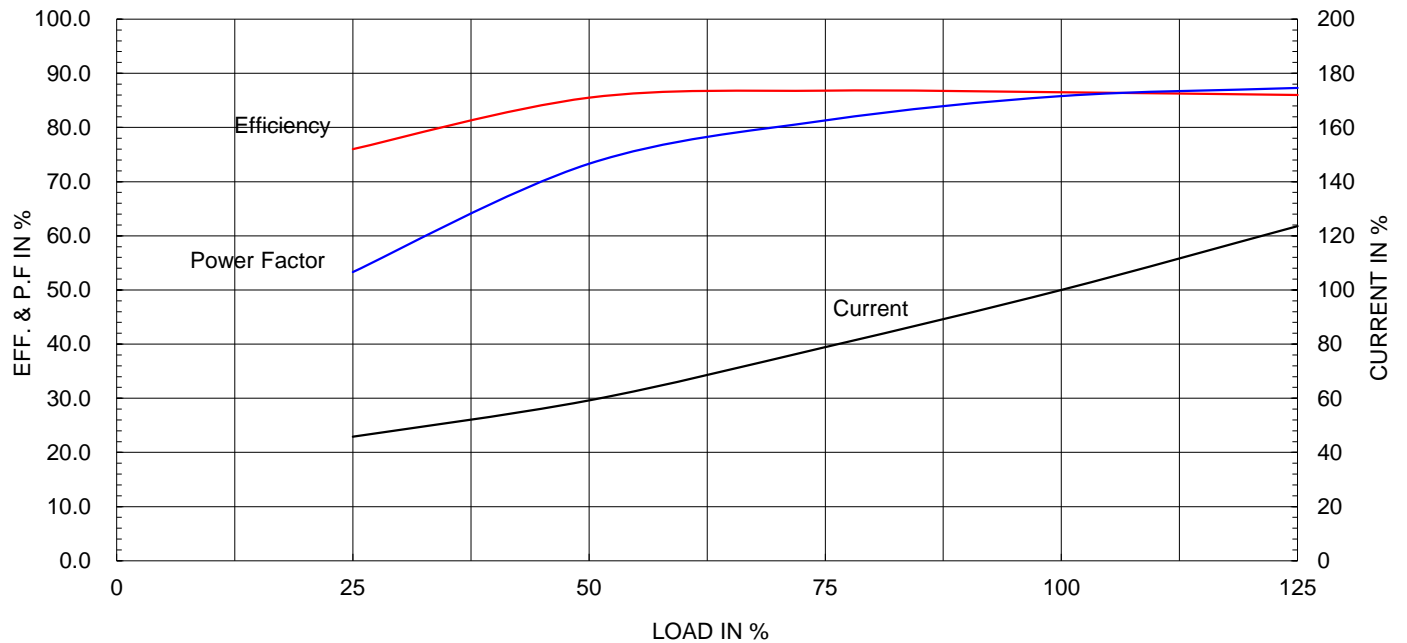
SPEED VS TORQUE & CURRENT CURVE

OUTPUT VS EFF., P.F & CURRENT CURVE

본 도면은 현대일렉트릭(주) 재산이므로
허가없이 복사할 수 없음 (취급주의)

THIS DRAWING IS PROPRIETARY TO HYUNDAI ELECTRIC. NO PART OF THIS DRAWING
MAY BE REPRODUCED WITHOUT THE PERMISSION OF HYUNDAI ELECTRIC.

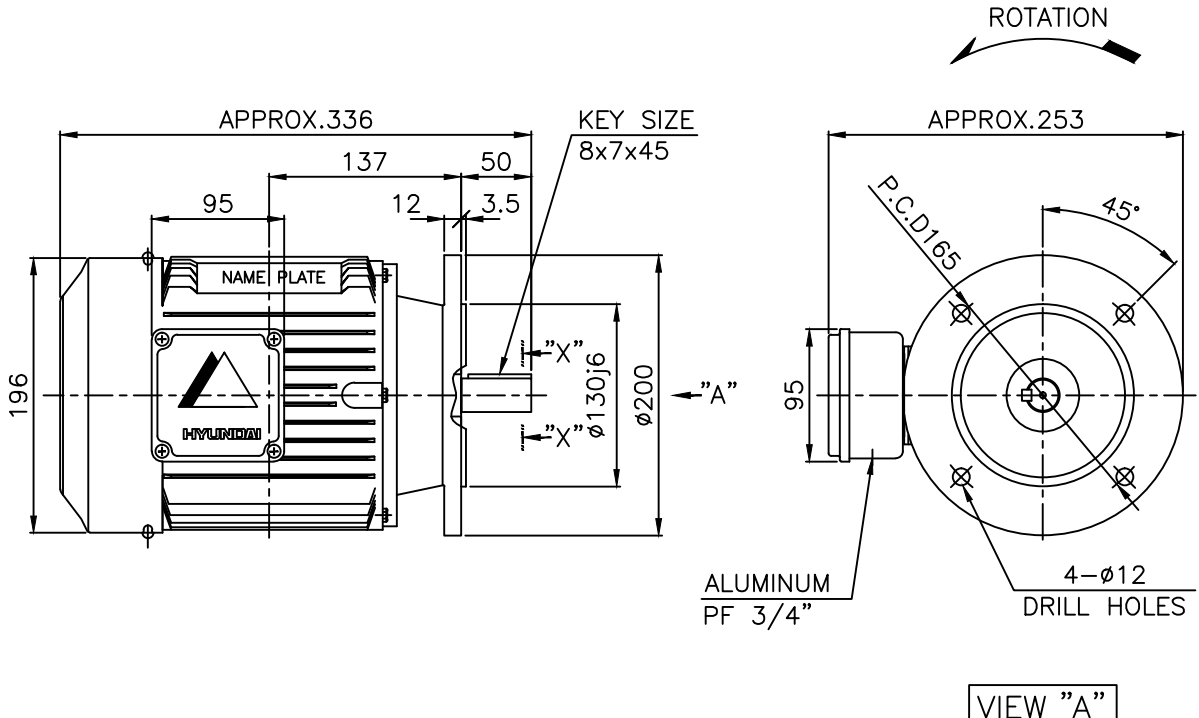
	1	2	3	4				
▽	50S	REV	DATE	CONTENTS	REVD BY	CHKD BY	CHKD BY	APPD BY
▽▽	12.5S							
▽▽▽	3.2S							
▽▽▽▽	0.4S							



NOTE

1. TOLERANCE :

FLANGE HOLES	$\phi 12$	$+0.43$ 0
RABBET DIAMETER	$\phi 130$	$+0.014$ -0.011
SHAFT DIAMETER	$\phi 24$	$+0.009$ -0.004
KEYWAY WIDTH	8	0 -0.036
KEYWAY DEPTH	4	$+0.2$ 0
KEY WIDTH	8	0 -0.036
KEY HEIGHT	7	0 -0.090

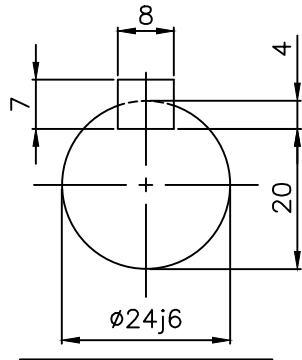

SECTION "X-X"

SCALE 5/5

APPD BY	S.K.HAN	UNIT	mm	SUBJECT	KS, IEC Fr.90L	DWG SIZE	A4 (1:5)
CHKD BY	S.Y.KIM	SCALE	1/5	TITLE OUTLINE			
CHKD BY	R.G.KIM	PROJEC'N	3각법 (3rd Angle)				
DSND BY	S.H.YUN	DATE	2018-08-08	REF. NO		Sheet No.	of
				DWG NO	LM-A1095B5P1001	Revision No.	0

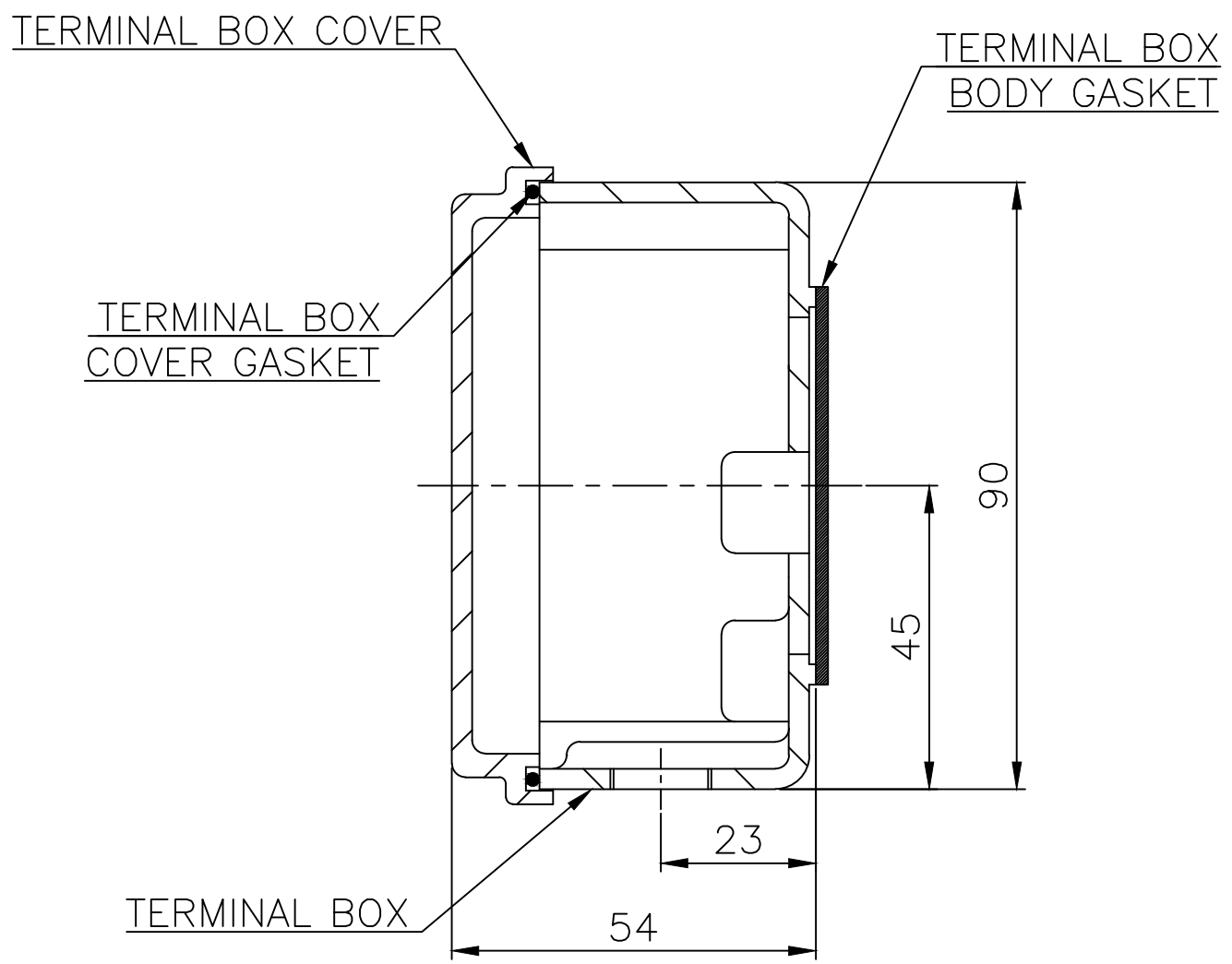
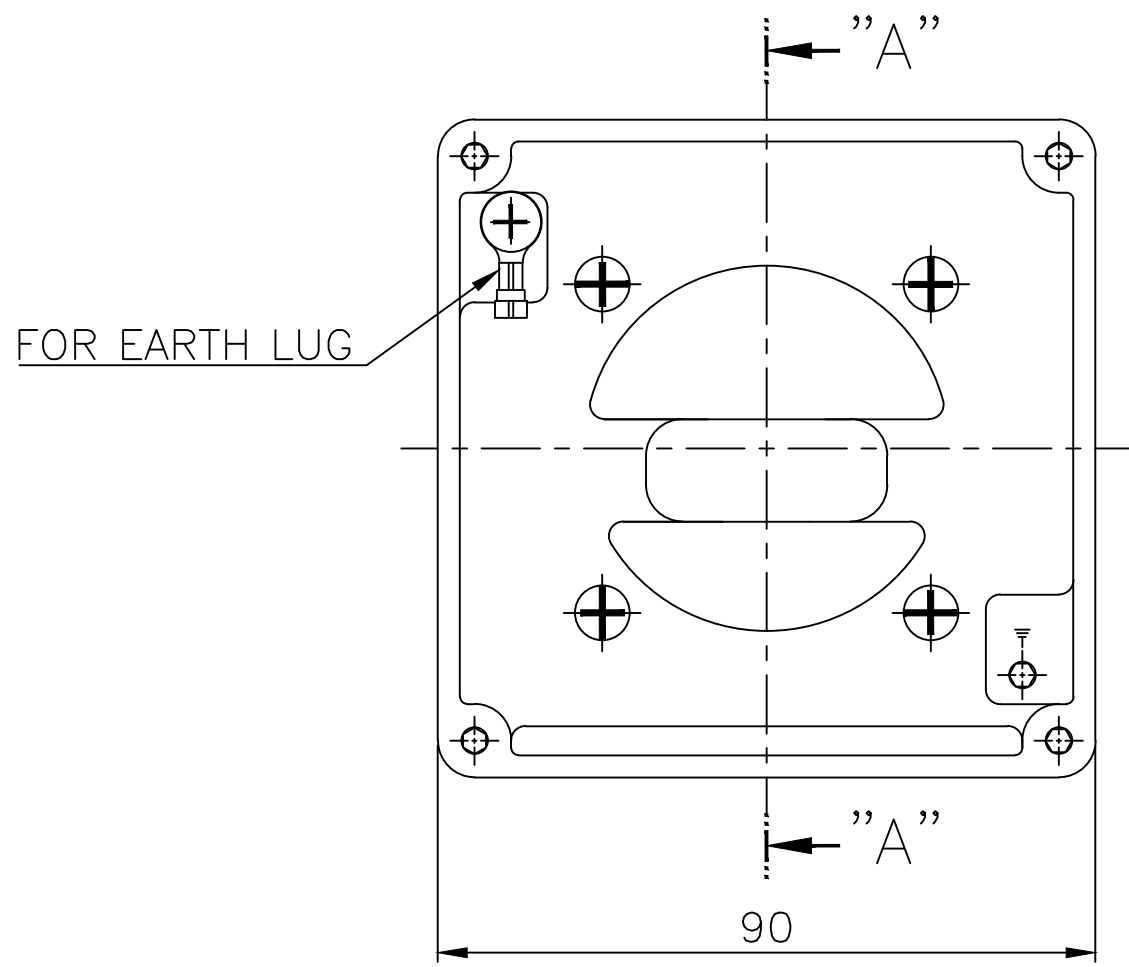

SEC. "A" - "A"

▽	50S
▽▽	12.5S
▽▽▽	3.2S
▽▽▽▽	0.4S

REV	DATE	CONTENTS	REVD BY	CHKD BY	CHKD BY	APPD BY

일반가공공차		일반제관공차	
1-4	±0.1	6-30	±0.5
4-18	±0.2	30-120	±0.8
18-63	±0.3	120-315	±1.2
63-250	±0.5	315-1000	±2.0
250-	±0.8	1000-	±3.0

Q'TY	DESCRIPTION	MATERIAL	DIMENSION	WEIGHT	PART NO.	REMARK	NO.
APPD BY	S.K.HAN	UNIT	mm	SUBJECT	FR.71~90 (AL)	DWG SIZE	A3 (1:1)
CHKD BY	S.Y.KIM	SCALE	1/1	TITLE Terminal Box Arrangement			
CHKD BY	R.G.KIM	PROJEC'N	3각법(3rd Angle)				
DSND BY	이혜경R	DATE	2011-10-26	REF. NO	227B1537AA	Sheet No.	of
				DWG NO	3M-148548	Revision No.	2