

Customer :  
Project Name :  
Project No. :  
Revision No. :

---

# SPECIFICATION for INDUCTION MOTOR

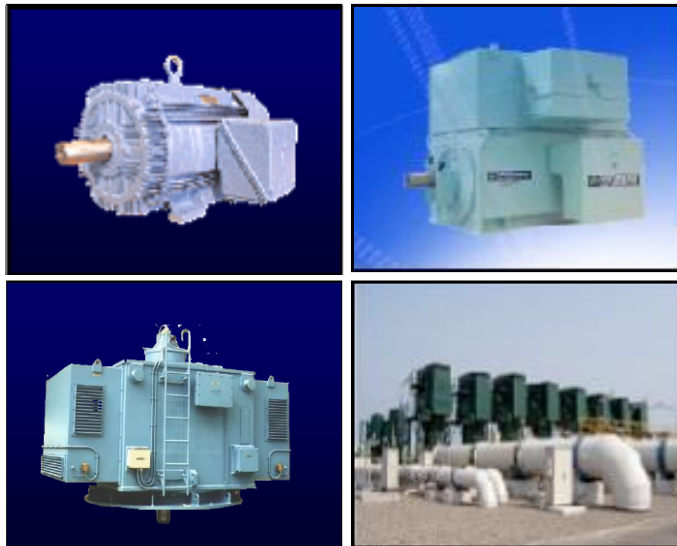

## Contents

- 1 . Data Sheet of AC Induction Motor - 1Sheets
- 2 . Speed-Torque & Current Curve - 1Sheets
- 3 . Outline Dimension Drawing - 1Sheets
- 4 . Main Terminal Box Drawing - 1Sheets



# AC INDUCTION MOTOR DATA SHEET

Model No.or RFQ No.	4606KSTD40SSDS1STFE3351DL0SDS	Item No.		Rev. No.	[     ]		
Project Name		Project No.		Quantity			
GENERAL SPECIFICATION			PERFORMANCE DATA				
Frame Size	180M	Rated Output	15 kW	20 HP			
Type	HLP-15/6	Number of Poles	6				
Enclosure(Protection)	Totally Enclosed ( IP55 )	Rotor Type	Squirrel Cage				
Method of Cooling	IC411(FC)	Starting Method*	<input checked="" type="checkbox"/> D.O.L	<input type="checkbox"/> Y-Δ			
Rated Frequency	60 Hz	Rated Voltage	460 V				
Number of Phases	3	Current	Full Load	26.7 A			
Insulation Class	<input checked="" type="checkbox"/> F <input type="checkbox"/> B <input type="checkbox"/> H		Locked-rotor**	750 %			
Temp. Rise at full load (by resistance method)		Efficiency					
at 1.0 S.F	80 deg. C	50% Load		88.7 %			
Motor Location	<input checked="" type="checkbox"/> Indoor <input type="checkbox"/> Outdoor	75% Load		91.7 %			
Altitude	Less than 1000	100% Load		91.7 %			
Relative Humidity	Less than 80 %	Power Factor(p.u)					
Ambient Temp.	40 deg. C (Max.)	50% Load		0.645			
Duty Type	Continuous(S1)	75% Load		0.730			
Service Factor	1.15	100% Load		0.770			
Mounting	<input type="checkbox"/> B3 <input type="checkbox"/> B5 <input type="checkbox"/> V1 <input checked="" type="checkbox"/> B3/B5	Speed at Full Load	1175 r.p.m				
Bearing	Type	Anti-Friction					
	DE/N-DE	6310ZZC3 / 6310ZZC3					
	Lubricant	Grease(Polyrex-EM)					
External Thrust	Not applicable						
Coupling Method	<input checked="" type="checkbox"/> Direct <input type="checkbox"/> V-Belt	Moment of Inertia (J)					
Shaft Extension	<input checked="" type="checkbox"/> Single <input type="checkbox"/> Double	Load(Max.)		26.500 kg·m <sup>2</sup>			
Terminal Box	Main	<input type="checkbox"/> Steel <input checked="" type="checkbox"/> Cast Iron	Motor		0.257 kg·m <sup>2</sup>		
	Aux.	<input type="checkbox"/> Yes <input checked="" type="checkbox"/> No	Sound Pressure Level (No-load & mean value at 1m from motor)				
	Location	Refer to Outline Drawing					
Application		Vibration					
Area classification	Not applicable	Permissible number of consecutive starts		Cold	3 times		
Type of Ex-Protection	Non-Hazardous			Hot	2 times		
Applicable Standard	KS, IEC, NEMA MG1 Part30(Vpeak)	Paint	Munsell No.	4.4PB5.5/5.6(VL-451)			
ACCESSORIES			SUBMITTAL DRAWING				
			Outline Dimension Drawing		Motor Weight(Approx.)		
			B3/B5	LM-T1183B4PL001	184 kg		
			Main T-Box Ass'y		3M-145860		
REMARK							
*.Premium Efficiency(IE3) *.For use on PWM VFD 10:1VT,3:1CT@1.0S.F&F Temp.rise							
SPARE PARTS							
		Date	DSND	CHKD	CHKD	APPD	
		2018-04-25	R.G. KIM	-	O.J. KIM	S.K. HAN	

Note: Others not mentioned in this data sheet shall be in accordance with maker standard.  
 Above technical data are only design values and shall be guaranteed with tolerance of applicable standard.  
 Inspection and performance test shall be maker standard, if not mentioned.  
 \* In case of Inverter-Fed Motor, performance data is based on sine wave tests.  
 \*\* The data are based on rated voltage & frequency, and data are expressed as a percentage of full load value.

Type :	HLP-15/6	
Full Load Torque :	12.4	kg.m
Motor moment of Inertia (J) :	0.257	kg.m <sup>2</sup>
Load moment of Inertia (J) :	26.500	kg.m <sup>2</sup>

15 kW	6 P	60 Hz
Speed at Full Load :		1175 RPM
Rated Voltage	460V	
Full Load Current	26.7A	

SPEED VS TORQUE & CURRENT CURVE

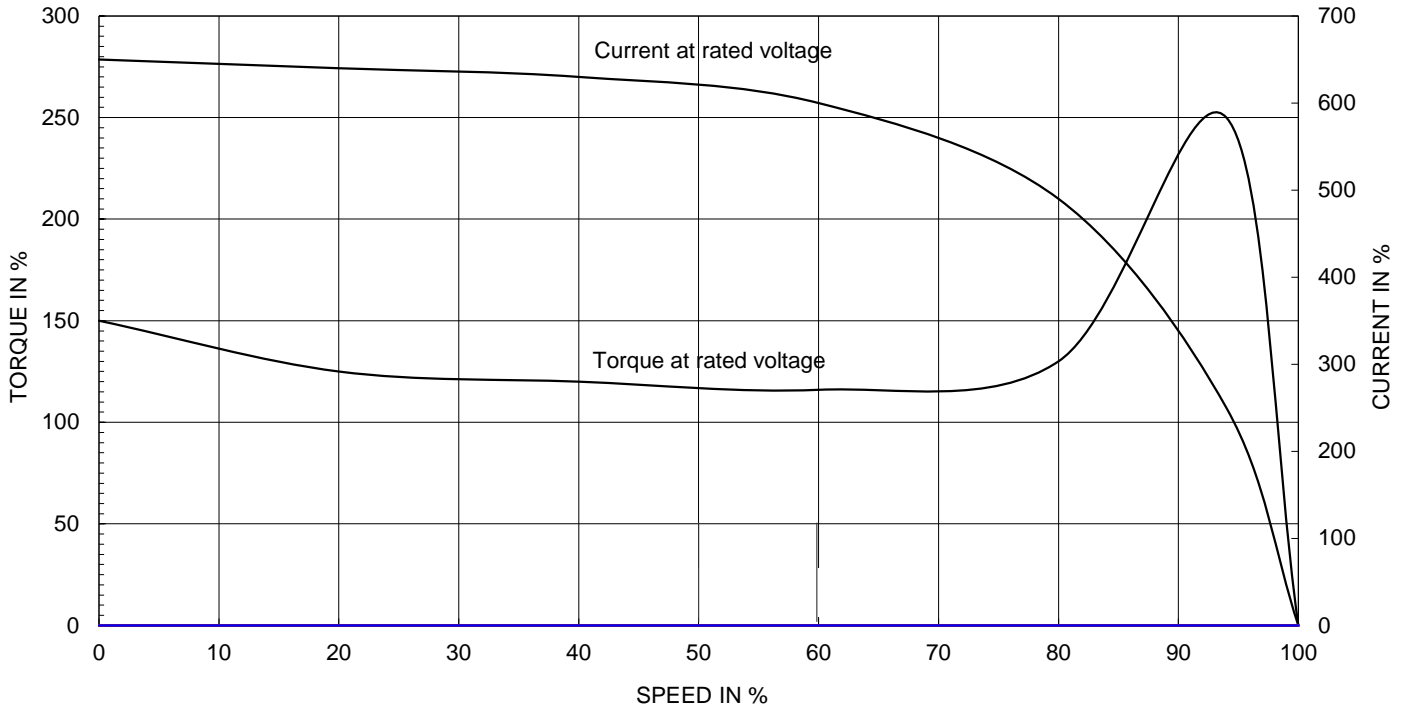

OUTPUT VS EFF., P.F & CURRENT CURVE

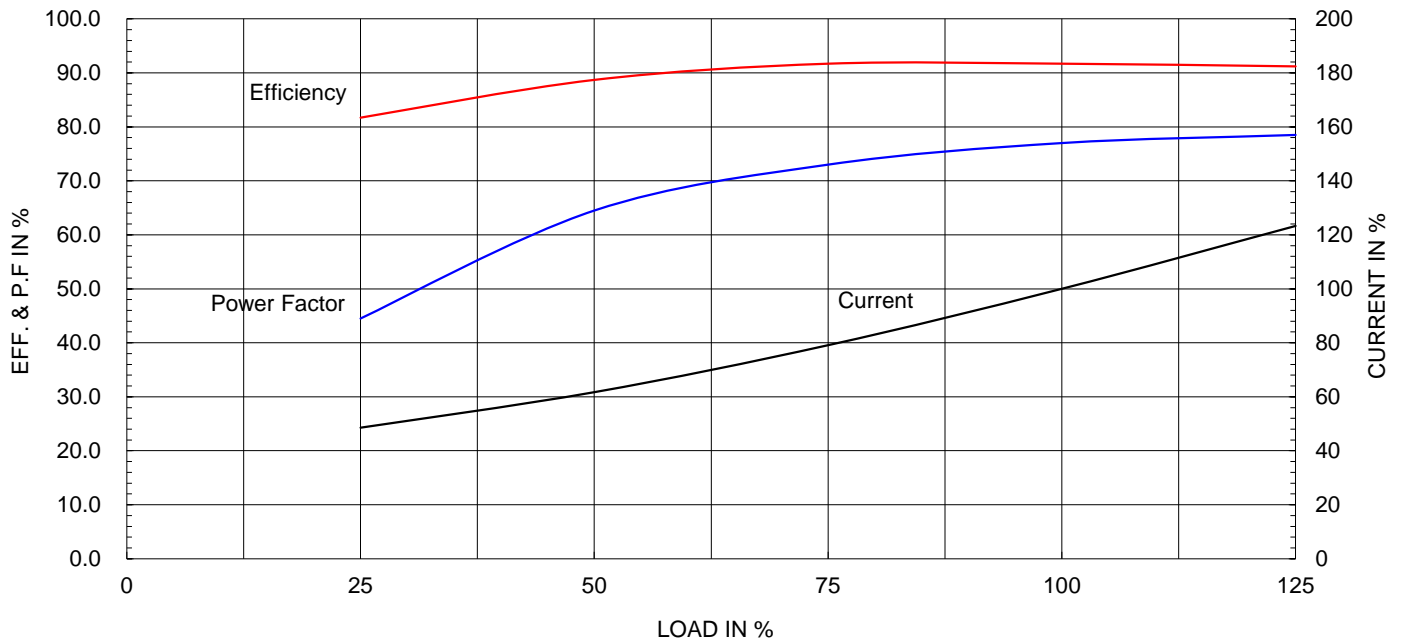

본 도면은 현대일렉트릭(주) 재산이므로  
허가없이 복사할 수 없음 (취급주의)

THIS DRAWING IS PROPRIETARY TO HYUNDAI ELECTRIC. NO PART OF THIS DRAWING  
MAY BE REPRODUCED WITHOUT THE PERMISSION OF HYUNDAI ELECTRIC.

	1	2	3	4				
▽	50S	REV	DATE	CONTENTS	REVD BY	CHKD BY	CHKD BY	APPD BY
▽▽	12.5S							
▽▽▽	3.2S							
▽▽▽▽	0.4S							

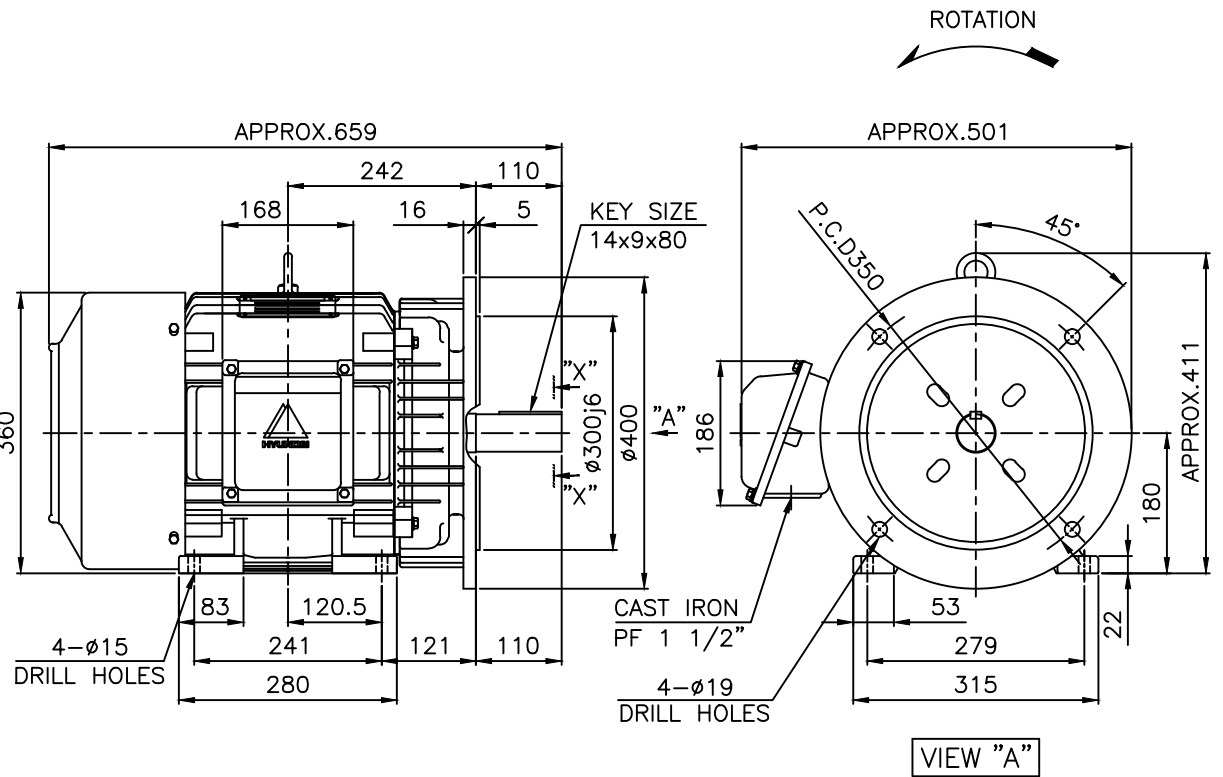

**NOTE**

1.TOLERANCE :

CENTER HEIGHT	180	0	-0.5
BASE HOLES	ø15	+0.43	0
FLANGE HOLES	ø19	+0.52	0
RABBET DIAMETER	ø300	±0.016	
SHAFT DIAMETER	ø48	+0.018	+0.002
KEYWAY WIDTH	14	0	-0.043
KEYWAY DEPTH	5.5	+0.2	0
KEY WIDTH	14	0	-0.043
KEY HEIGHT	9	0	-0.090

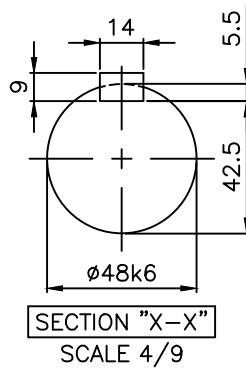

APPD BY	S.K.HAN	UNIT	mm	SUBJECT	KS, IEC Fr.180M	DWG SIZE	A4 ( 1:9 )
CHKD BY	S.Y.KIM	SCALE	1/9	TITLE	OUTLINE		
CHKD BY	R.G.KIM	PROJEC'N	3각법 (3rd Angle)	REF. NO		Sheet No.	of
DSND BY	장성근	DATE	2011-10-22	DWG NO	LM-T1183B4PL001	Revision No.	3

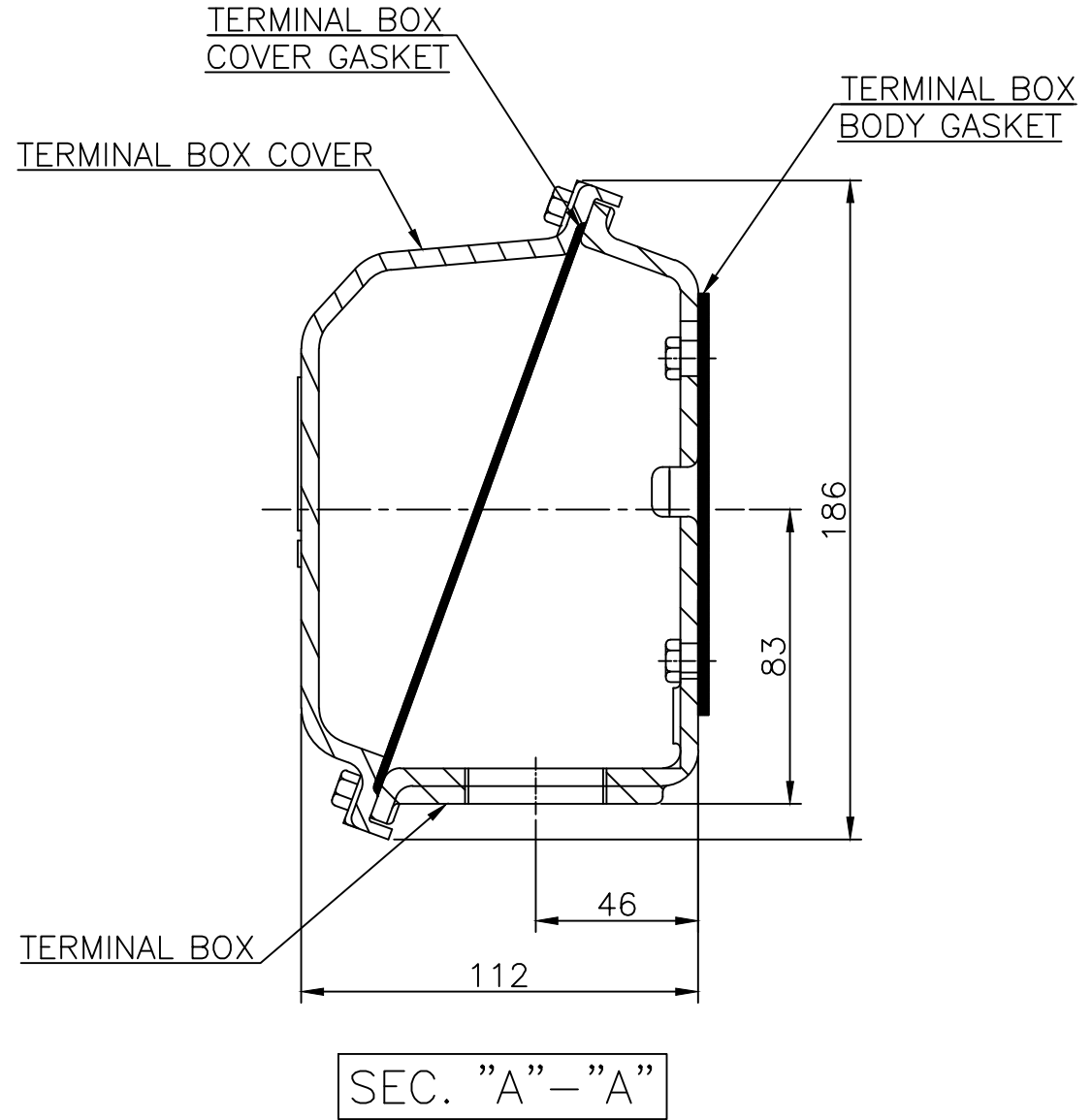
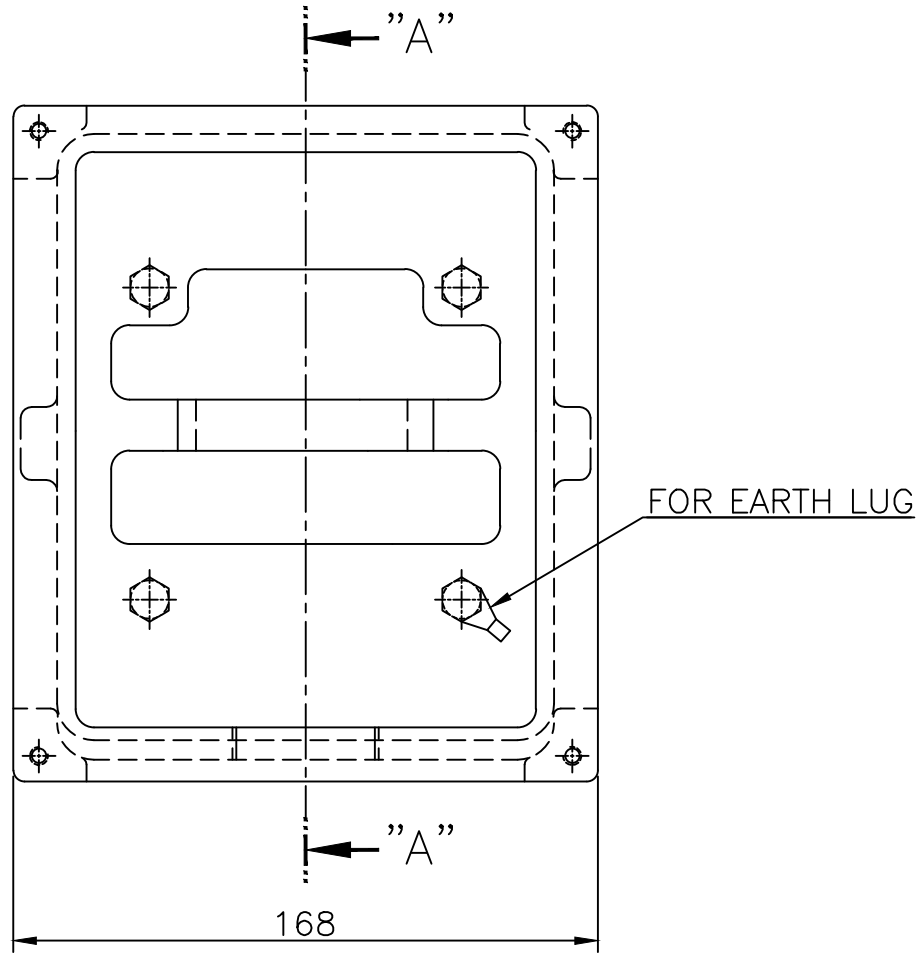

▽	50S
▽▽	12.5S
▽▽▽	3.2S
▽▽▽▽	0.4S

REV	DATE	CONTENTS	REVD BY	CHKD BY	CHKD BY	APPD BY

일반가공공차		일반제관공차	
1-4	±0.1	6-30	±0.5
4-18	±0.2	30-120	±0.8
18-63	±0.3	120-315	±1.2
63-250	±0.5	315-1000	±2.0
250-	±0.8	1000-	±3.0

Q'TY	DESCRIPTION	MATERIAL	DIMENSION	WEIGHT	PART NO.	REMARK	NO.
APPD BY	S.K.HAN	UNIT	mm	SUBJECT	FR.160~180 (CAST IRON)		DWG SIZE
CHKD BY	S.Y.KIM	SCALE	1/2	TITLE			A3 (1:2)
CHKD BY	R.G.KIM	PROJEC'N	3각법(3rd Angle)	Main Terminal Box Assembly			
DSND BY	H.K.LEE	DATE	2011-08-30	REF. NO.	227B8008LA2	Sheet No.	of
				DWG NO.	3M-145860	Revision No.	2