

Customer :  
Project Name :  
Project No. :  
Revision No. :

---

# SPECIFICATION for INDUCTION MOTOR



## Contents

- |                                      |           |
|--------------------------------------|-----------|
| 1 . Data Sheet of AC Induction Motor | - 1Sheets |
| 2 . Speed-Torque & Current Curve     | - 1Sheets |
| 3 . Outline Dimension Drawing        | - 1Sheets |
| 4 . Main Terminal Box Drawing        | - 1Sheets |

# AC INDUCTION MOTOR DATA SHEET

Model No.or RFQ No.	2206KSTD40SSDS1STFE3V11DL0SDS	Item No.		Rev. No.	[     ]		
Project Name		Project No.		Quantity			
GENERAL SPECIFICATION			PERFORMANCE DATA				
Frame Size	90L	Rated Output	1.5 kW	2 HP			
Type	HLP-1.5/2	Number of Poles	2				
Enclosure(Protection)	Totally Enclosed ( IP55 )	Rotor Type	Squirrel Cage				
Method of Cooling	IC411(FC)	Starting Method*	<input checked="" type="checkbox"/> D.O.L	<input type="checkbox"/> Y-Δ			
Rated Frequency	60 Hz	Rated Voltage	220 V				
Number of Phases	3	Current	Full Load	5.4 A			
Insulation Class	<input checked="" type="checkbox"/> F <input type="checkbox"/> B <input type="checkbox"/> H		Locked-rotor**	950 %			
Temp. Rise at full load (by resistance method) at 1.0 S.F		Efficiency					
80 deg. C		50% Load		82.0 %			
Motor Location <input checked="" type="checkbox"/> Indoor <input type="checkbox"/> Outdoor		75% Load		85.7 %			
Altitude Less than 1000		100% Load		85.5 %			
Relative Humidity Less than 80 %		Power Factor(p.u)					
Ambient Temp. 40 deg. C (Max.)		50% Load		0.720			
Duty Type Continuous(S1)		75% Load		0.810			
Service Factor 1.15		100% Load		0.852			
Mounting <input type="checkbox"/> B3 <input type="checkbox"/> B5 <input checked="" type="checkbox"/> V1 <input type="checkbox"/> B3/B5		Speed at Full Load		3500 r.p.m			
Bearing	Type	Anti-Friction					
	DE/N-DE	6205ZZ / 6204ZZ					
	Lubricant	Grease(HIFLEX L-3)					
External Thrust		Not applicable					
Coupling Method <input checked="" type="checkbox"/> Direct <input type="checkbox"/> V-Belt		Moment of Inertia (J)					
Shaft Extension <input checked="" type="checkbox"/> Single <input type="checkbox"/> Double		Load(Max.)		0.250 kg·m <sup>2</sup>			
Terminal Box	Main	<input type="checkbox"/> Steel <input checked="" type="checkbox"/> Cast Iron		Motor			
	Aux.	<input type="checkbox"/> Yes <input checked="" type="checkbox"/> No		0.002 kg·m <sup>2</sup>			
	Location	Refer to Outline Drawing					
Application		Sound Pressure Level (No-load & mean value at 1m from motor)					
Area classification Not applicable		73 dB(A)					
Type of Ex-Protection Non-Hazardous		Vibration 1.6 mm/sec (r.m.s)					
Applicable Standard KS, IEC, NEMA MG1 Part30(Vpeak)		Permissible number of consecutive starts		Cold 3 times			
				Hot 2 times			
		Paint	Munsell No.	4.4PB5.5/5.6(VL-451)			
ACCESSORIES			SUBMITTAL DRAWING				
		Outline Dimension Drawing \		Motor Weight(Approx.)			
		V1		LM-A1095V1P1001	21 kg		
		Main T-Box Ass'y		3M-148548			
REMARK							
*.Premium Efficiency(IE3) *.For use on PWM VFD 10:1VT,3:1CT@1.0S.F&F Temp.rise							
SPARE PARTS							
		Date	DSND	CHKD	CHKD	APPD	
		2018-04-25	R.G. KIM	-	O.J. KIM	S.K. HAN	

Note: Others not mentioned in this data sheet shall be in accordance with maker standard.  
 Above technical data are only design values and shall be guaranteed with tolerance of applicable standard.  
 Inspection and performance test shall be maker standard, if not mentioned.  
 \* In case of Inverter-Fed Motor, performance data is based on sine wave tests.  
 \*\* The data are based on rated voltage & frequency, and data are expressed as a percentage of full load value.

Type :	HLP-1.5/2	
Full Load Torque :	0.4	kg.m
Motor moment of Inertia (J) :	0.002	kg.m <sup>2</sup>
Load moment of Inertia (J) :	0.250	kg.m <sup>2</sup>

1.5 kW	2 P	60 Hz
Speed at Full Load :		3500 RPM
Rated Voltage	220V	
Full Load Current	5.4A	

SPEED VS TORQUE &amp; CURRENT CURVE

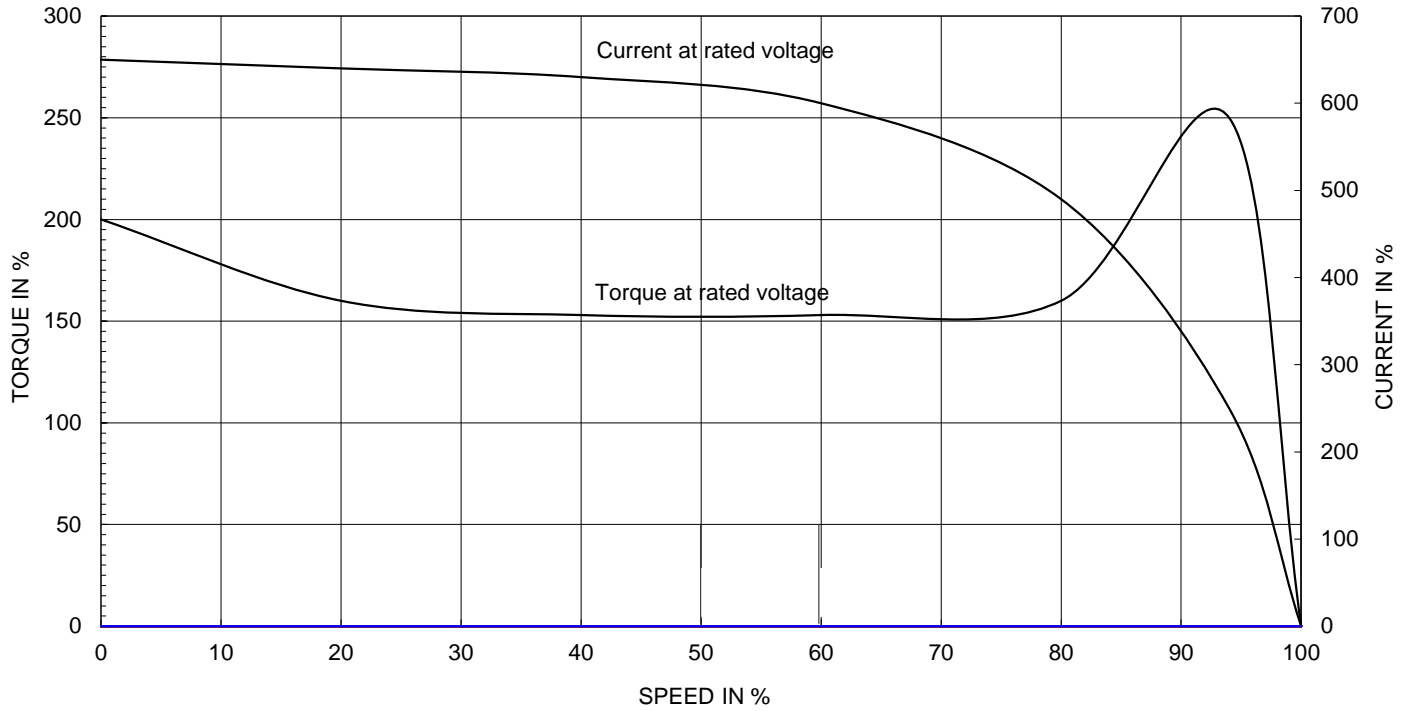

OUTPUT VS EFF., P.F &amp; CURRENT CURVE

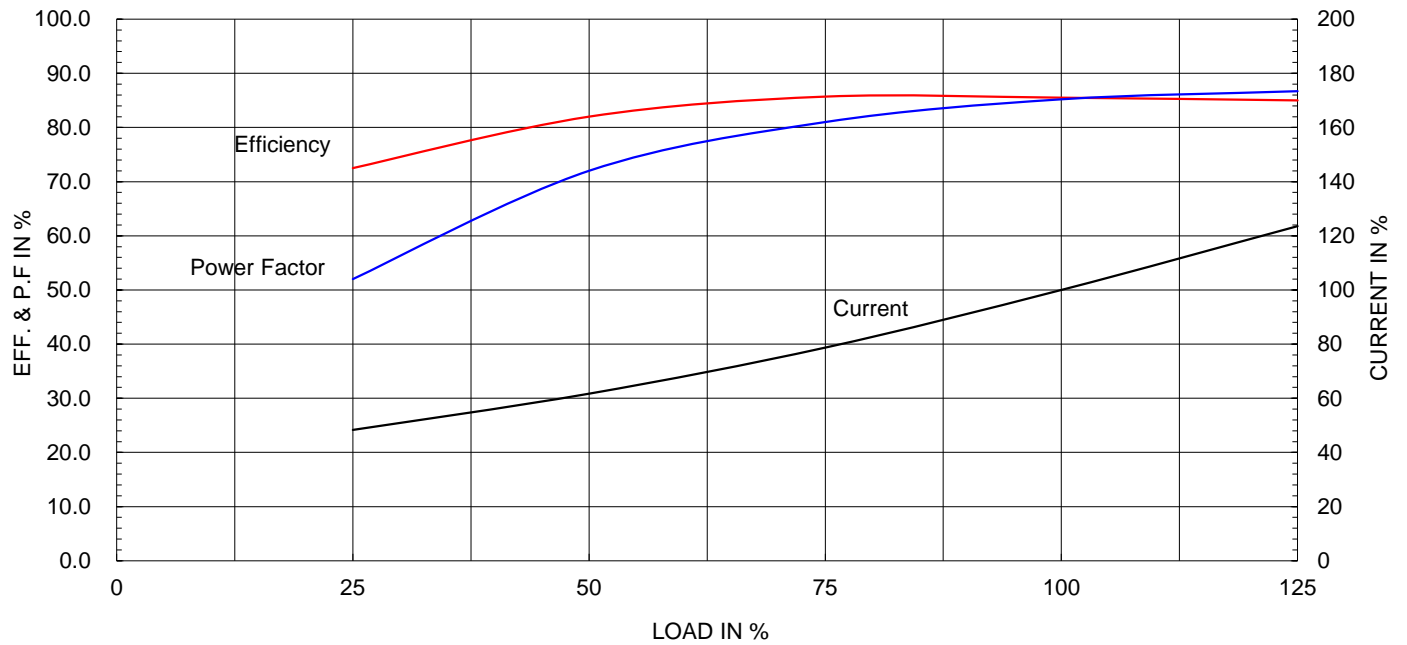

본 도면은 현대일렉트릭(주) 재산이므로  
허가없이 복사할 수 없음 (취급주의)

THIS DRAWING IS PROPRIETARY TO HYUNDAI ELECTRIC. NO PART OF THIS DRAWING  
MAY BE REPRODUCED WITHOUT THE PERMISSION OF HYUNDAI ELECTRIC.

	1	2	3	4				
▽	50S	REV	DATE	CONTENTS	REVD BY	CHKD BY	CHKD BY	APPD BY
▽▽	12.5S							
▽▽▽	3.2S							
▽▽▽▽	0.4S							

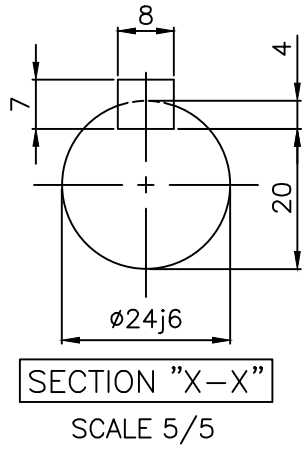
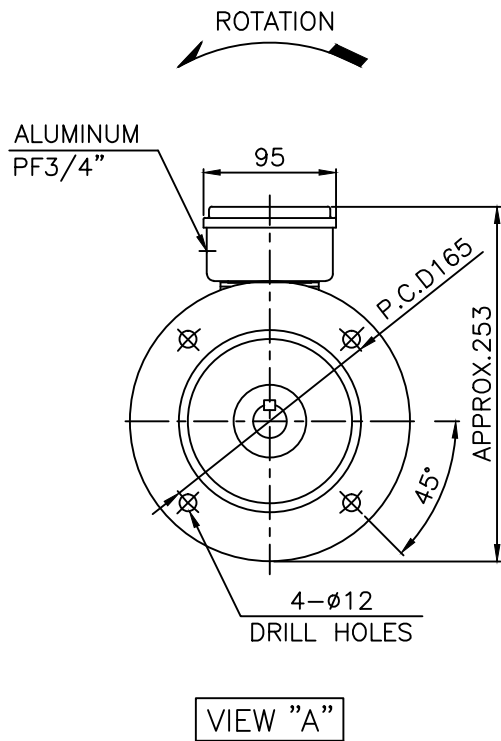
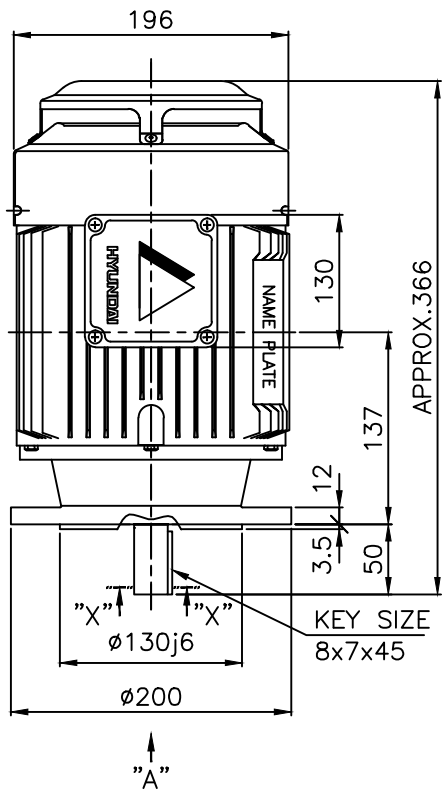

**NOTE**

1.TOLERANCE :

FLANGE HOLES	$\phi 12$	$+0.43$ $0$
RABBET DIAMETER	$\phi 130$	$+0.014$ $-0.011$
SHAFT DIAMETER	$\phi 24$	$+0.009$ $-0.004$
KEYWAY WIDTH	8	$0$ $-0.036$
KEYWAY DEPTH	4	$+0.2$ $0$
KEY WIDTH	8	$0$ $-0.036$
KEY HEIGHT	7	$0$ $-0.090$

APPD BY	S.K.HAN	UNIT	mm	SUBJECT	KS, IEC Fr.90L	DWG SIZE	A4 ( 15 )
CHKD BY	S.Y.KIM	SCALE	1/5	TITLE <b>OUTLINE</b>			
CHKD BY	R.G.KIM	PROJEC'N	3각법 (3rd Angle)				
DSND BY	S.H.YUN	DATE	2018-07-03				
				REF. NO		Sheet No.	of
				DWG NO	LM-A1095V1P1001	Revision No.	0

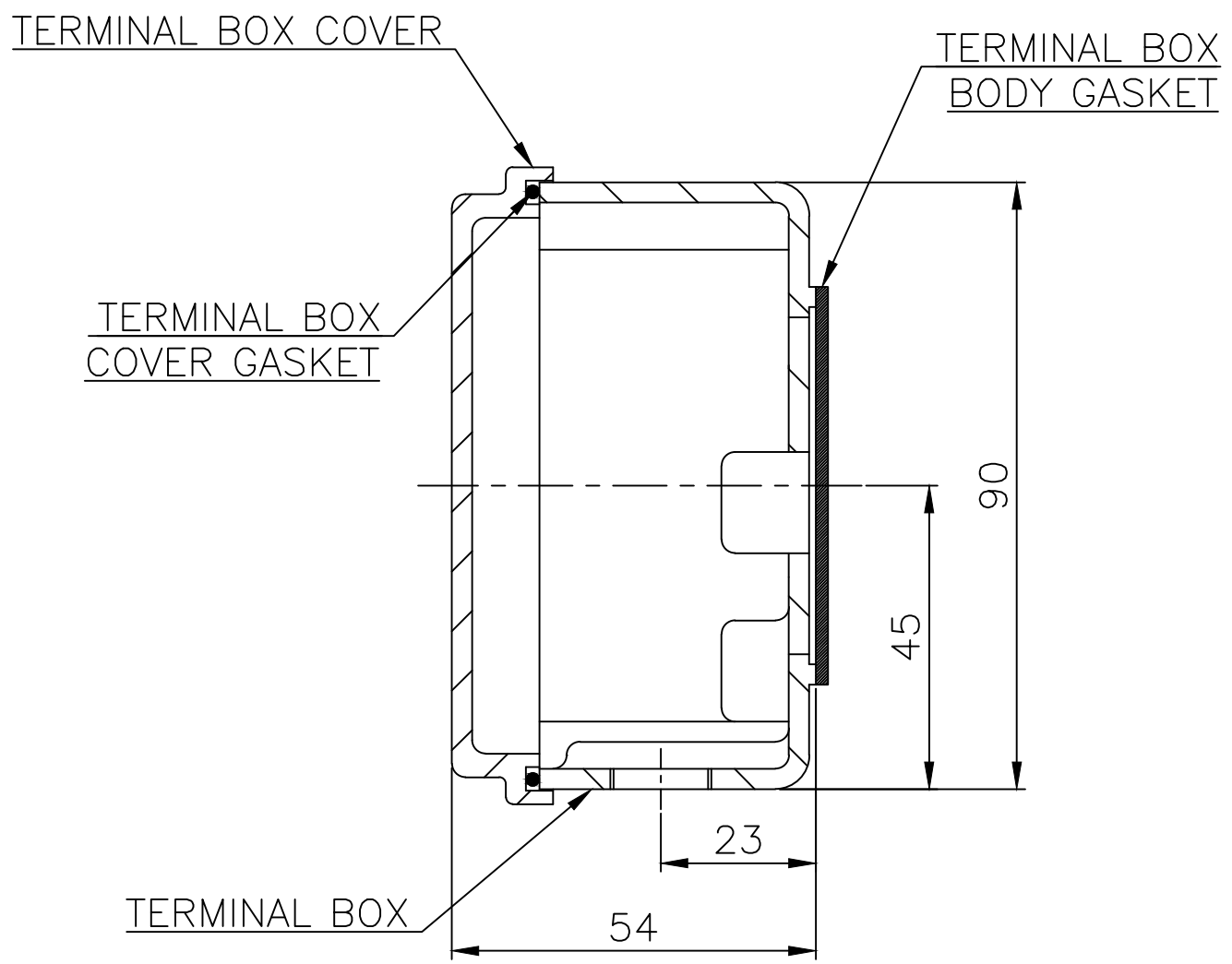
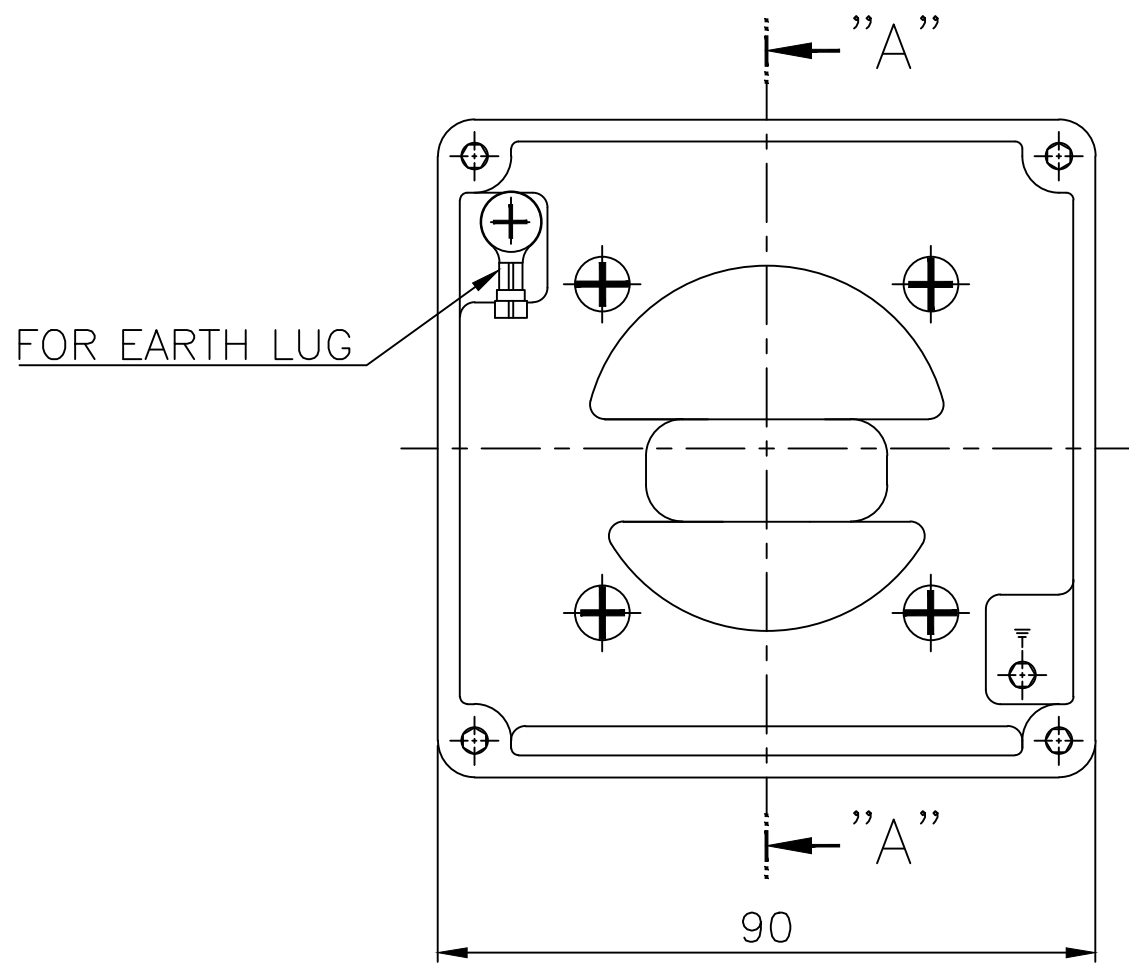

SEC. "A" - "A"

▽	50S
▽▽	12.5S
▽▽▽	3.2S
▽▽▽▽	0.4S

REV	DATE	CONTENTS	REVD BY	CHKD BY	CHKD BY	APPD BY

일반가공공차		일반제관공차	
1-4	±0.1	6-30	±0.5
4-18	±0.2	30-120	±0.8
18-63	±0.3	120-315	±1.2
63-250	±0.5	315-1000	±2.0
250-	±0.8	1000-	±3.0

Q'TY	DESCRIPTION	MATERIAL	DIMENSION	WEIGHT	PART NO.	REMARK	NO.
APPD BY	S.K.HAN	UNIT	mm	SUBJECT	FR.71~90 (AL)	DWG SIZE	A3 ( 1:1 )
CHKD BY	S.Y.KIM	SCALE	1/1	TITLE Terminal Box Arrangement			
CHKD BY	R.G.KIM	PROJEC'N	3각법(3rd Angle)				
DSND BY	이혜경R	DATE	2011-10-26	REF. NO	227B1537AA	Sheet No.	of
				DWG NO	3M-148548	Revision No.	2