

AC INDUCTION MOTOR DATA SHEET

Model No.or RFQ No.		Item No.		Rev. No. [0]			
Project Name		Project No.		Quantity sets			
GENERAL SPECIFICATION			PERFORMANCE DATA				
Frame Size	160M		Rated Output	7.5 kW 10 HP			
Type	HL-XP		Number of Poles	6			
Enclosure(Protection)	Explosion Proof (IP55)		Rotor Type	Squirrel Cage			
Method of Cooling	IC411(FC)		Starting Method*	<input checked="" type="checkbox"/> D.O.L <input type="checkbox"/> Y- Δ			
Rated Frequency	60 Hz		Rated Voltage	440 V	380 V 220 V		
Number of Phases	3		Current	Full Load	14.5 A 16.8 A 28.9 A		
Insulation Class	<input checked="" type="checkbox"/> F <input type="checkbox"/> B <input type="checkbox"/> H		Locked-rotor**	650 %	650 % 650 %		
Temp. Rise at full load (by resistance method)			Efficiency				
at 1.0 S.F 80 deg. C			50% Load 88.7 %				
Motor Location	<input checked="" type="checkbox"/> Indoor <input type="checkbox"/> Outdoor		75% Load 90.0 %				
Altitude	Less than 1000 meter		100% Load 89.5 %				
Relative Humidity	Less than 80 %		Power Factor(p.u)				
Ambient Temp.	40 deg. C (Max.)		50% Load 0.580				
Duty Type	Continuos (S1)		75% Load 0.706				
Service Factor	1.00		100% Load 0.760				
Mounting	<input type="checkbox"/> B3 <input checked="" type="checkbox"/> B5 <input type="checkbox"/> V1 <input type="checkbox"/> B3/B5		Speed at Full Load 1170 r.p.m				
Bearing	Type	Anti-Friction		Torque			
	DE/N-DE	6309ZZC3 / 6309ZZC3		Full Load 6.2 kg·m			
	Lubricant	Grease(Polyrex-EM)		Locked-rotor** 170 %			
External Thrust	Not applicable		Breakdown** 250 %				
Coupling Method	<input checked="" type="checkbox"/> Direct <input type="checkbox"/> V-Belt		Moment of Inertia (J)				
Shaft Extension	<input checked="" type="checkbox"/> Single <input type="checkbox"/> Double		Load(Max.) 15.000 kg·m ²				
Terminal Box	Main	<input type="checkbox"/> Steel <input checked="" type="checkbox"/> Cast Iron		Motor 0.090 kg·m ²			
	Aux.	<input type="checkbox"/> Yes <input checked="" type="checkbox"/> No		Sound Pressure Level (No-load & mean value at 1m from motor)			
	Location	Refer to Outline Drawing		64 dB(A)			
Application			Vibration 2.2 mm/sec (r.m.s)				
Area classification	Hazardous		Permissible number of consecutive starts				
Type of Ex-Protection	Ex d IIB T4		Cold 3 times				
Applicable Standard	KS,IEC		Hot 2 times				
			Paint	Munsell No.	4.0PB5.4/5.5(VL-451)		
ACCESSORIES			SUBMITTAL DRAWING				
			Outline Dimension Drawing \ Motor Weight(Approx.)				
			B3		kg		
			B5	227B2022AA05	145 kg		
			V1		kg		
			B3/B5		0 kg		
			Main T-Box Ass'y 227B1470LB				
SPARE PARTS			REMARK				
			High Efficiency				
			Date	DSND	CHKD	CHKD	APPD
			2011-04-14	W.H.BACK	S. J. RA	O. J. KIM	J. H. KIM

Note: Others not mentioned in this data sheet shall be in accordance with maker standard.
 Above technical data are only design values and shall be guaranteed with tolerance of applicable standard.
 Inspection and performance test shall be maker standard, if not mentioned.
 * In case of Inverter-Fed Motor, performance data is based on sine wave tests.
 ** Data is based on when the motor is supplied at rated voltage & frequency, and the data is expressed as a percentage of full-load value.

Type	:	HL-XP
Full Load Torque	:	6.2 Kg.m
Motor moment of Inertia (J)	:	0.090 Kg.m ²
Load moment of Inertia (J)	:	15.000 Kg.m ²

7.5 kW	6 P	60 Hz	
Speed at Full Load :		1170 RPM	
Rated Voltage	440V	380V	220V
Full Load Current	14.5A	16.8A	28.9A

SPEED VS TORQUE & CURRENT CURVE

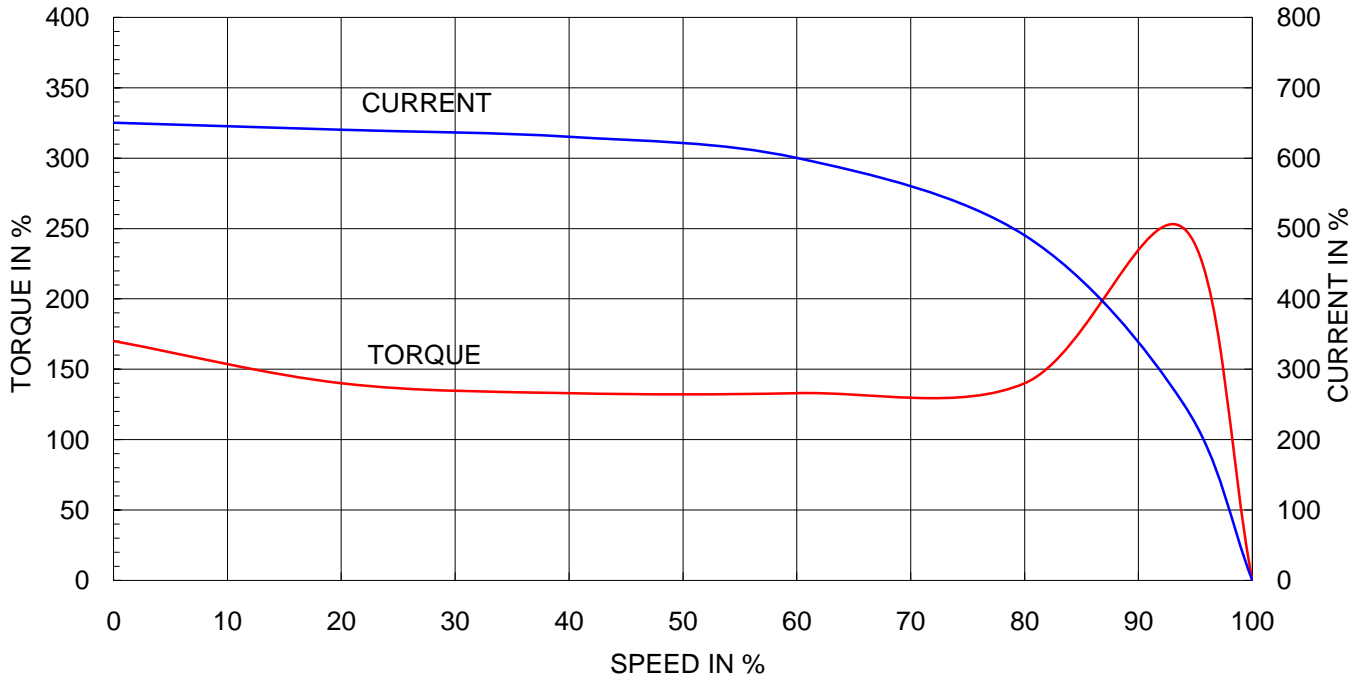

OUTPUT VS EFF., P.F & CURRENT CURVE

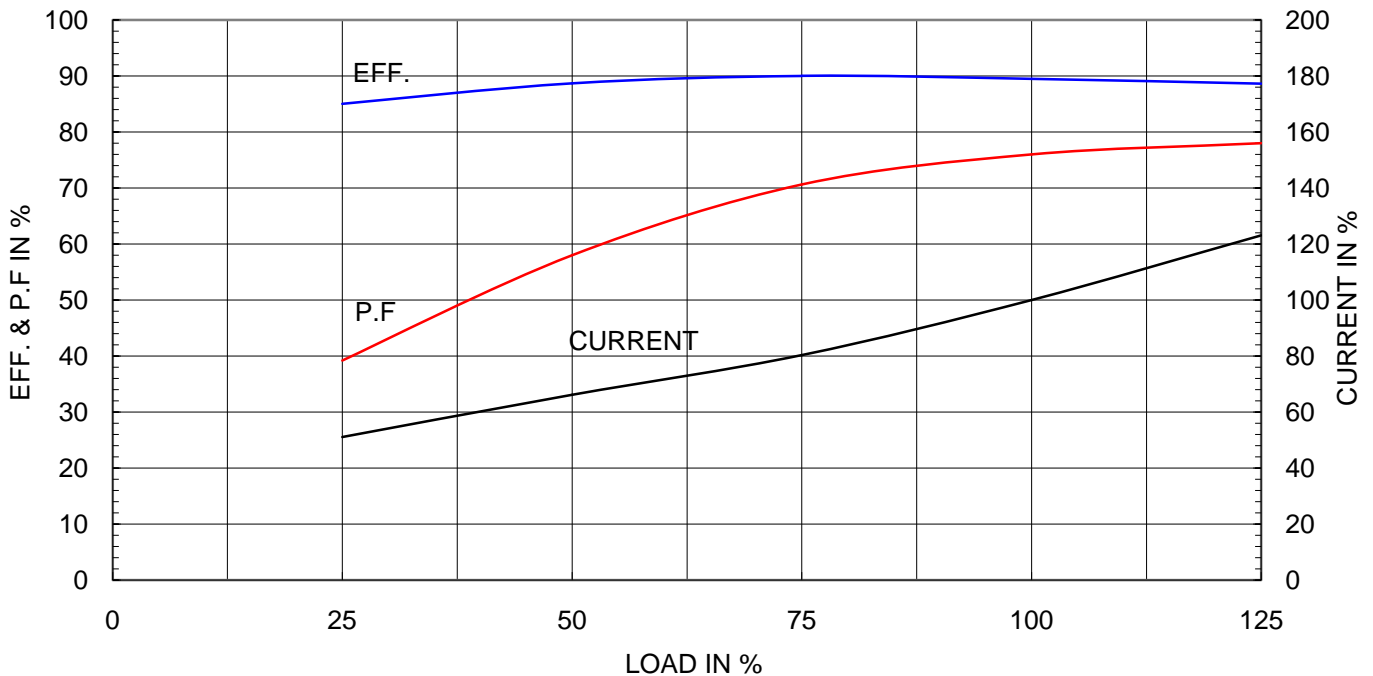



TEFC

THREE PHASE INDUCTION MOTOR

TYPE

HL, HLS

CAST IRON FRAME

Exd II

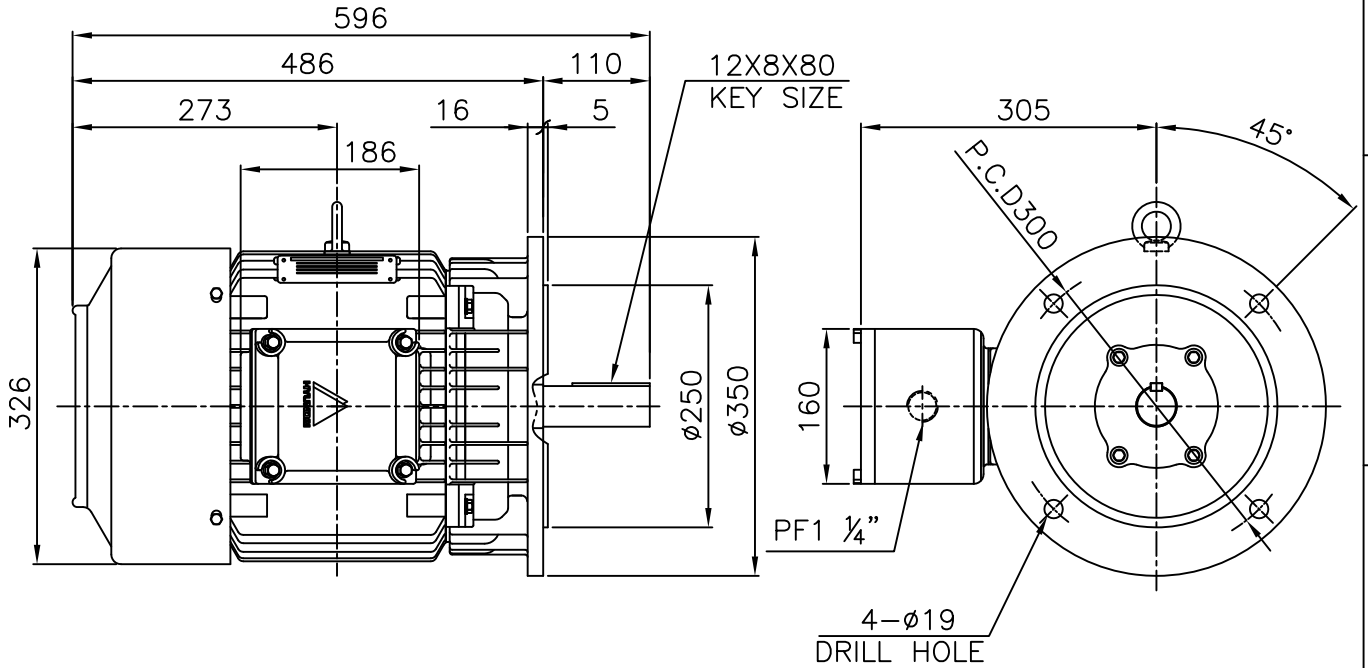

NOTE

1.TOLERANCE :

FLANGE HOLES	$\phi 19$	$\begin{matrix} +0.43 \\ 0 \end{matrix}$
RABBET DIAMETER	$\phi 250$	$\begin{matrix} +0.016 \\ -0.013 \end{matrix}$
SHAFT DIAMETER	$\phi 42$	$\begin{matrix} +0.018 \\ +0.002 \end{matrix}$
KEYWAY WIDTH	12	$\begin{matrix} 0 \\ -0.043 \end{matrix}$
KEYWAY DEPTH	5	$\begin{matrix} +0.2 \\ 0 \end{matrix}$

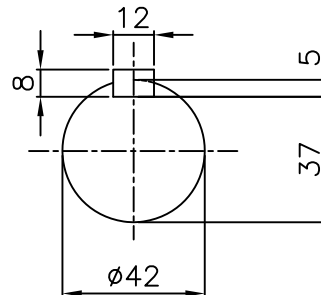

APPD BY	Y. S. KIM	UNIT	mm	SUBJECT	KS 160M	CAD PROJ \ FILE
CHKD BY	K. S. LEE	SCALE	1/8			XSDNKS\B2022AA05
CHKD BY	-----	PROJEC'N	3rd Angle	TITLE OUTLINE		
DSND BY	I. K. KIM	DATE	2008.10.22			
				REF. NO	B2022AA05	Sheet No. of
				DWG NO	227B2022AA05	Revision No. 0

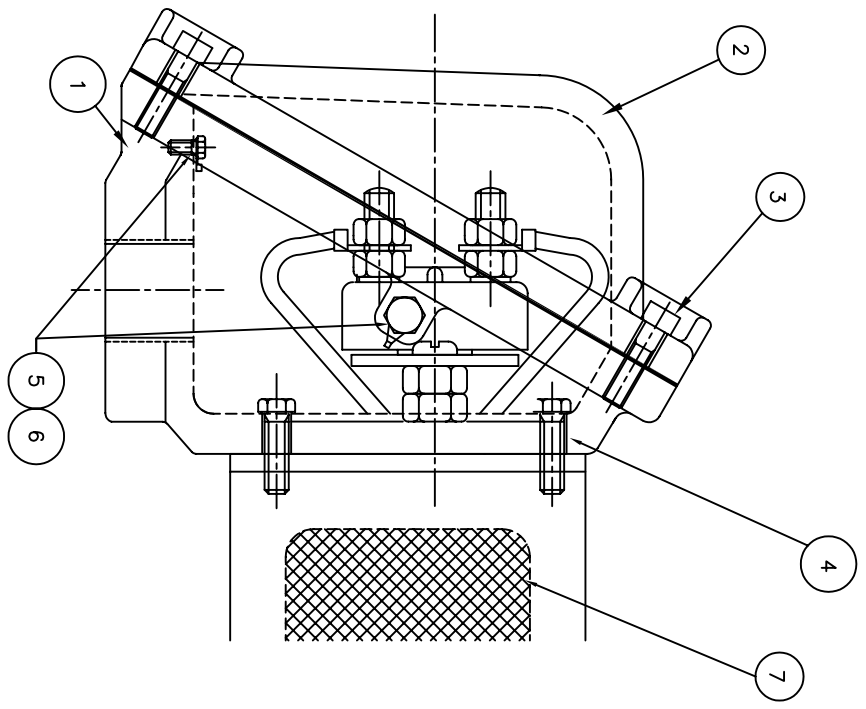
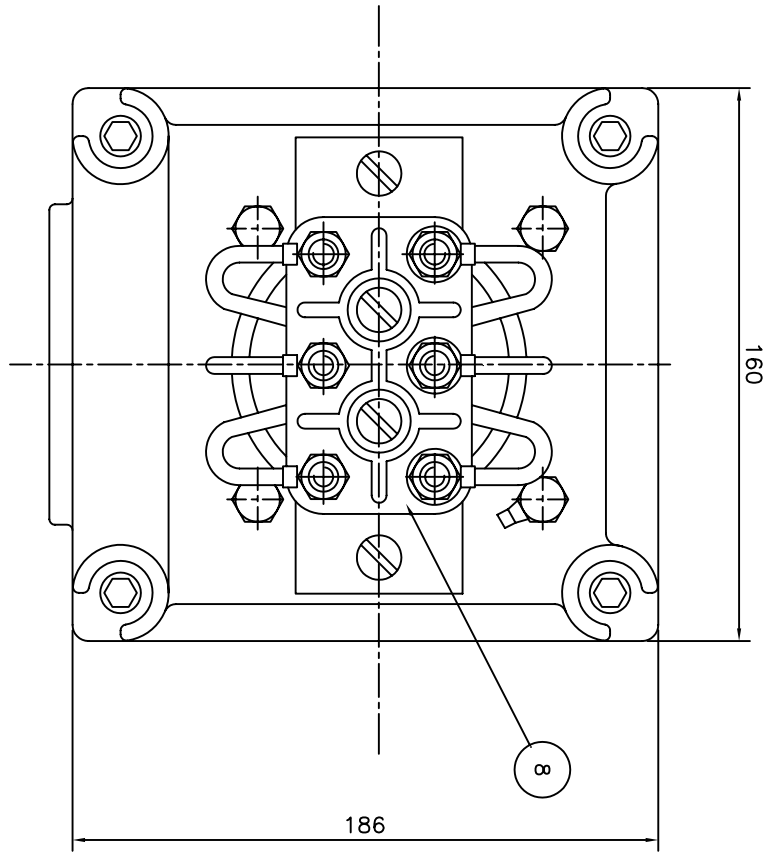

Q'TY	DESCRIPTION	MATERIAL	DIMENSION	WEIGHT	PART NO.	REMARK	NO.
1	TERMINAL BLOCK	D4C29C					8
1	SEALING COMPOUND	CU					7
2	GRD. TERMINAL LUG	S45C					6
2	GRD. BOLT	S45C					5
4	T/B + FRAME BOLT	S45C					4
4	T/B + COVER BOLT	S45C					3
1	TERMINAL BOX COVER	FC15					2
1	TERMINAL BOX ASSEMBLY	FC15					1

APPD BY	UNIT	MATERIAL	DIMENSION	WEIGHT	PART NO.	REMARK	NO.
CHKD BY	SCALE	N/S	SUBJECT	IEC 160/180FR d2G4		CAD PROJ \FILE XSMOUT\7B1468LB	
CHKD BY	PROJEC'N	3*48 (3rd Angle)	TITLE	MAIN TERMINAL BOX			
DSND BY	DATE	99.2.2	REF. NO	7B1470LB	Sheet No.	of	
	DESIGNER	LEE E.J.	DWG NO	227B1470LB	Revision No.	0	

REV	DATE	CONTENTS	REVD BY	CHKD BY	CHKD BY	APPD BY
1						
2						
3						
4						

HYUNDAI
HEAVY INDUSTRIES CO. LTD.
ELECTRICAL ENGINEERING DIVISION