



AC INDUCTION MOTOR DATA SHEET

Model No.or RFQ No.		Item No.		Rev. No. [0]			
Project Name		Project No.		Quantity sets			
GENERAL SPECIFICATION			PERFORMANCE DATA				
Frame Size	200LL		Rated Output	45 kW 60 HP			
Type	HK-XP		Number of Poles	4			
Enclosure(Protection)	Explosion Proof (IP55)		Rotor Type	Squirrel Cage			
Method of Cooling	IC411(FC)		Starting Method*	<input checked="" type="checkbox"/> D.O.L <input type="checkbox"/> Y- Δ			
Rated Frequency	60 Hz		Rated Voltage	440 V	380 V 220 V		
Number of Phases	3		Current	Full Load	76.0 A 88.0 A 152.0 A		
Insulation Class	<input checked="" type="checkbox"/> F <input type="checkbox"/> B <input type="checkbox"/> H			Locked-rotor**	670 % 670 % 670 %		
Temp. Rise at full load (by resistance method)			Efficiency				
at 1.0 S.F 80 deg. C			50% Load 93.6 %				
Motor Location <input checked="" type="checkbox"/> Indoor <input type="checkbox"/> Outdoor			75% Load 93.7 %				
Altitude Less than 1000 meter			100% Load 93.6 %				
Relative Humidity Less than 80 %			Power Factor(p.u)				
Ambient Temp. 40 deg. C (Max.)			50% Load 0.775				
Duty Type Continuous (S1)			75% Load 0.820				
Service Factor 1.00			100% Load 0.830				
Mounting <input checked="" type="checkbox"/> B3 <input type="checkbox"/> B5 <input type="checkbox"/> V1 <input type="checkbox"/> B3/B5			Speed at Full Load 1775 r.p.m				
Bearing	Type	Anti-Friction		Torque			
	DE/N-DE	6313ZC3 / 6211ZC3		Full Load	24.7 kg·m		
Lubricant		Grease(Gadus S2 V 100 2)		Locked-rotor**	150 %		
External Thrust Not applicable			Breakdown** 210 %				
Coupling Method <input checked="" type="checkbox"/> Direct <input type="checkbox"/> V-Belt			Moment of Inertia (J)				
Shaft Extension <input checked="" type="checkbox"/> Single <input type="checkbox"/> Double			Load(Max.) 26.000 kg·m ²				
Terminal Box	Main	<input type="checkbox"/> Steel <input checked="" type="checkbox"/> Cast Iron		Motor 0.546 kg·m ²			
	Aux.	<input type="checkbox"/> Yes <input checked="" type="checkbox"/> No		Sound Pressure Level (No-load & mean value at 1m from motor)			
Location Refer to Outline Drawing			78 dB(A)				
Application			Vibration 2.2 mm/sec (r.m.s)				
Area classification Hazardous			Permissible number of consecutive starts				
Type of Ex-Protection Ex d II T4			Cold 3 times				
Applicable Standard KS,IEC			Hot 2 times				
			Paint	Munsell No.	4.0PB5.4/5.5(VL-451)		
ACCESSORIES			SUBMITTAL DRAWING				
			Outline Dimension Drawing \ Motor Weight(Approx.)				
			B3	227B1600XI10	370 kg		
			B5		kg		
			V1		kg		
			B3/B5	0	0 kg		
			Main T-Box Ass'y	227B1470LA			
SPARE PARTS			REMARK				
			High Efficiency				
			Date	DSND	CHKD	CHKD	APPD
			2010-05-28	R.G. KIM	O.J. KIM	J.H. KIM	K.J. KANG

Note: Others not mentioned in this data sheet shall be in accordance with maker standard.
 Above technical data are only design values and shall be guaranteed with tolerance of applicable standard.
 Inspection and performance test shall be maker standard, if not mentioned.
 * In case of Inverter-Fed Motor, performance data is based on sine wave tests.
 ** Data is based on when the motor is supplied at rated voltage & frequency, and the data is expressed as a percentage of full-load value.

Type	:	HL-XP
Full Load Torque	:	24.7 Kg.m
Motor moment of Inertia (J)	:	0.546 Kg.m ²
Load moment of Inertia (J)	:	26.000 Kg.m ²

45 kW	4 P	60 Hz	
Speed at Full Load :		1775 RPM	
Rated Voltage	440V	380V	220V
Full Load Current	76.0A	88.0A	152.0A

SPEED VS TORQUE & CURRENT CURVE

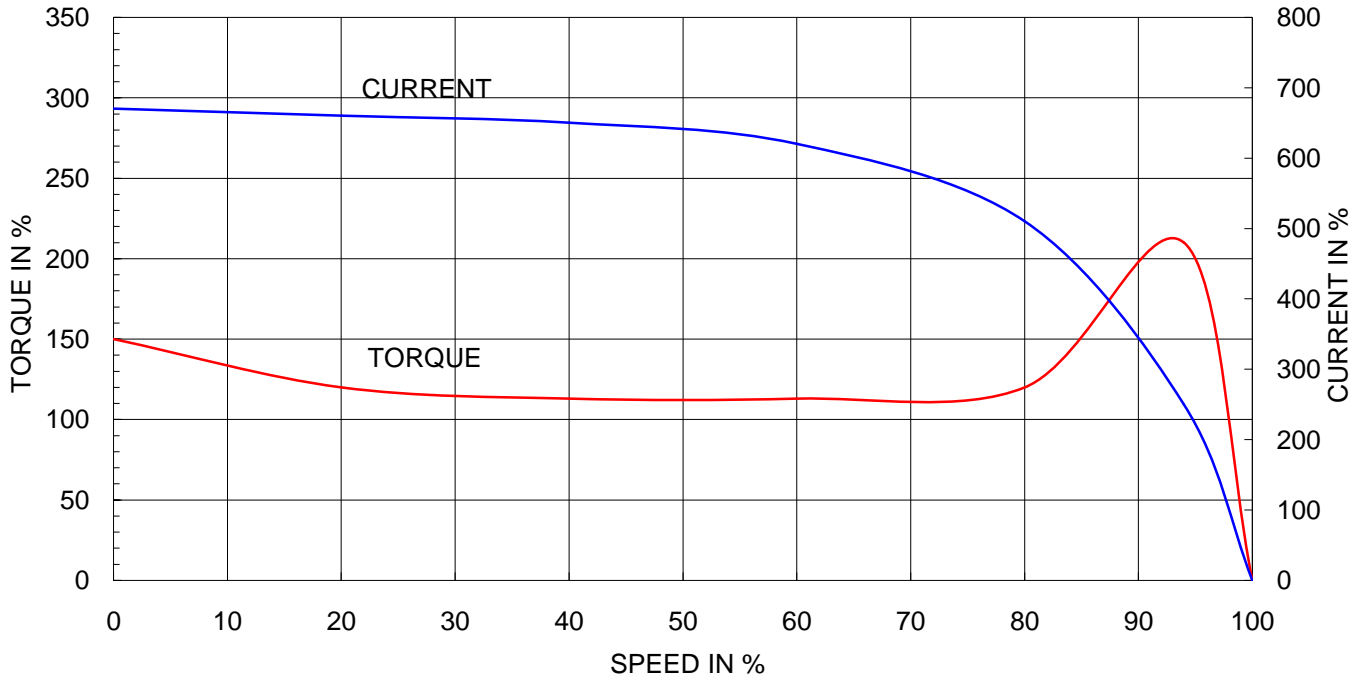

OUTPUT VS EFF., P.F & CURRENT CURVE

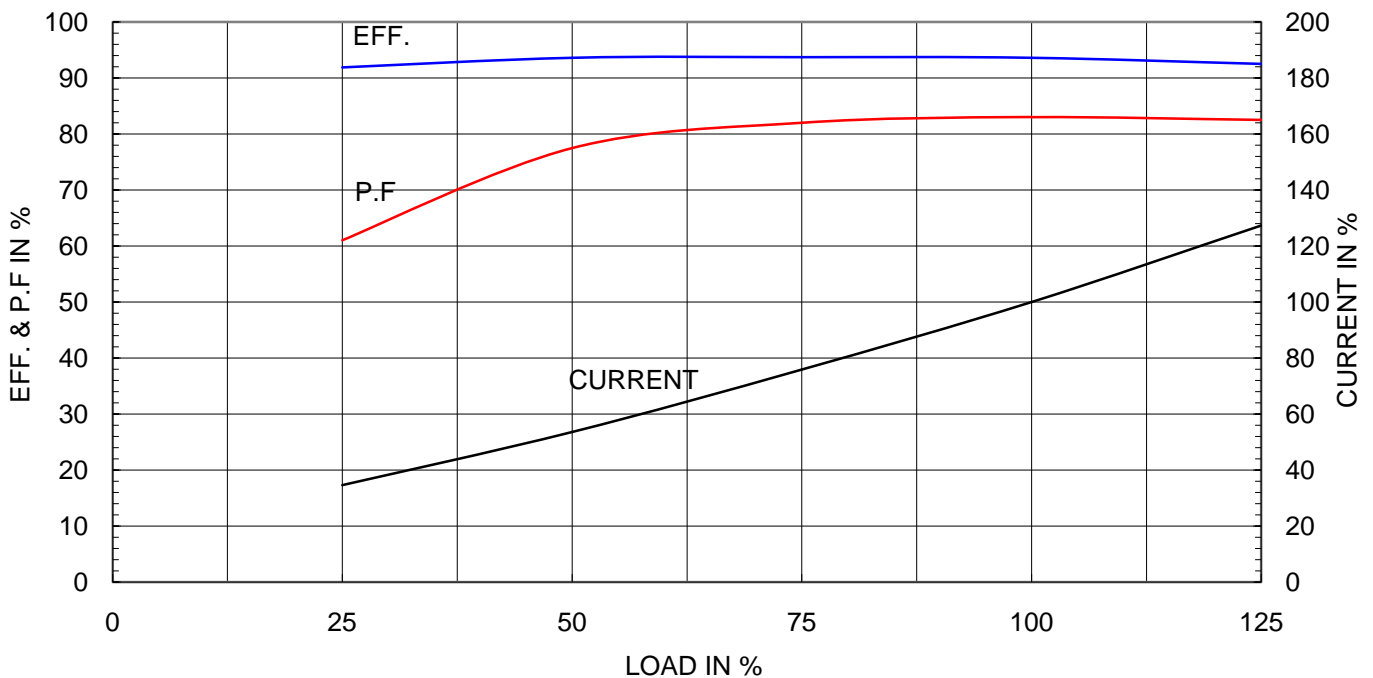

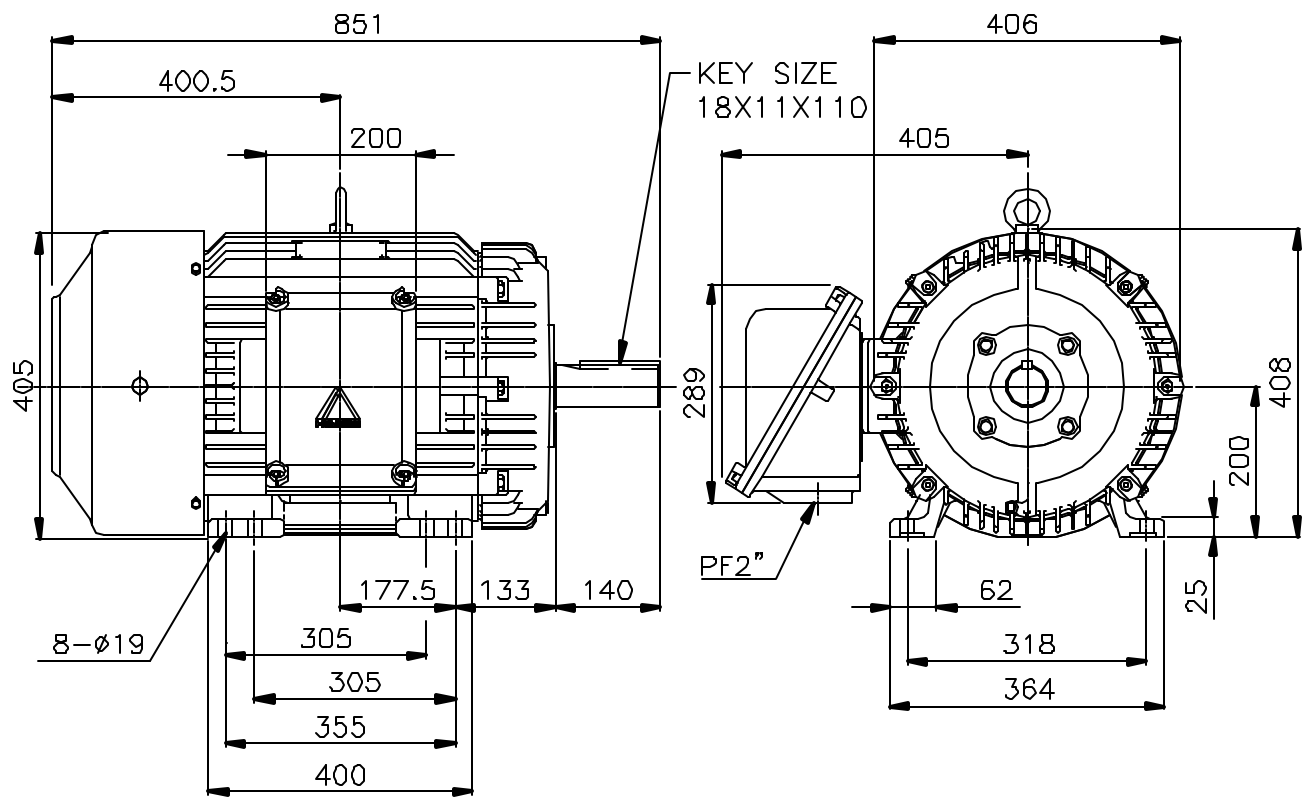

NOTE

1.TOLERANCE :

CENTER HEIGHT	200	+0	-0.5
BASE HOLES	ø19	+0.43	-0
SHAFT DIAMETER	ø60	+0.030	+0.011
KEYWAY WIDTH	18	+0	-0.043
KEYWAY DEPTH	7	+0	-0.2

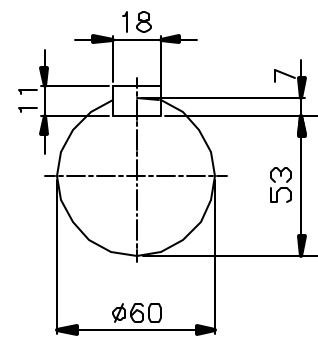

APPD BY	J. H. KIM	UNIT	mm	SUBJECT	KS 200LL 4,6P d2G4	CAD PROJ \ FILE
CHKD BY	Y. S. KIM	SCALE	1/10			XSDNKS\B2001AA10
CHKD BY	S. H. KO	PROJEC'N	3rd Angle	TITLE OUTLINE		
DSND BY	I. K. KIM	DATE	2002.10.31			
				REF. NO	B1600X110	Sheet No. of
				DWG NO	227B1600X110	Revision No. 0

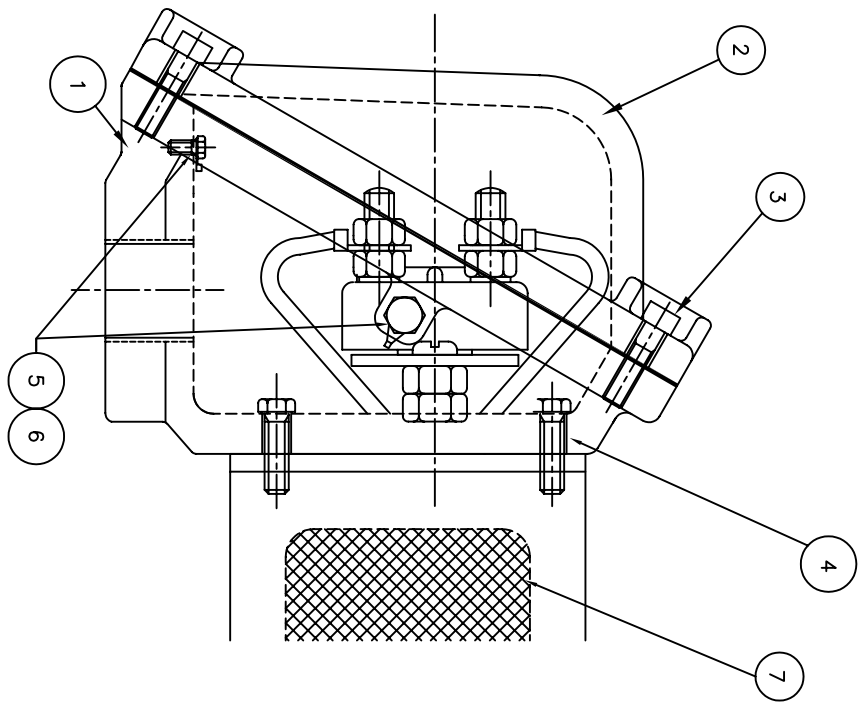
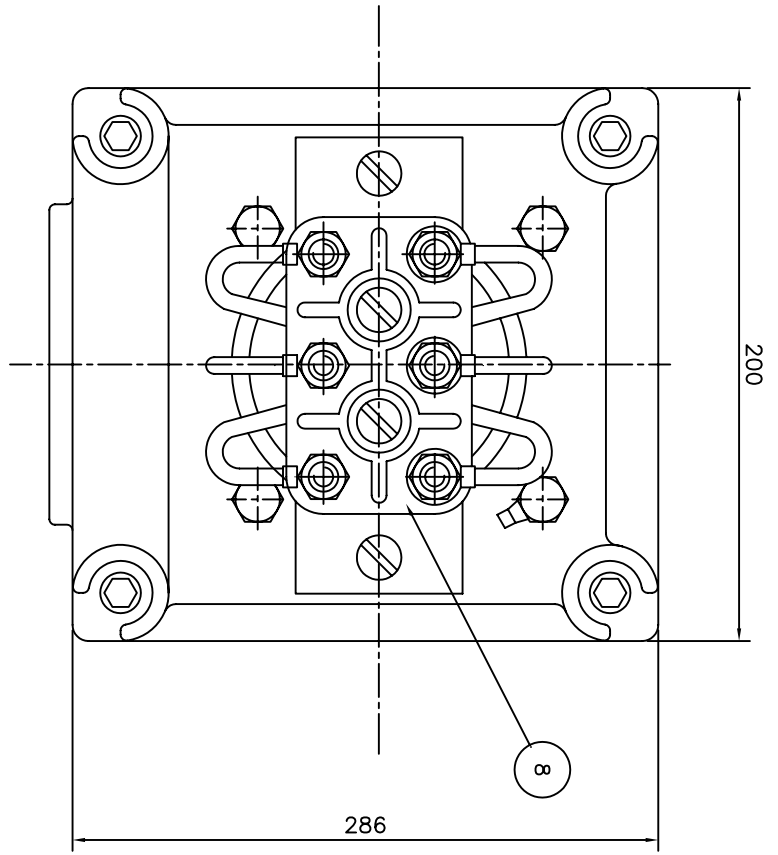

Q'TY	DESCRIPTION	MATERIAL	DIMENSION	WEIGHT	PART NO.	REMARK	NO.
1	TERMINAL BLOCK	D4C29C					8
1	SEALING COMPOUND	CU					7
2	GRD. TERMINAL LUG	S45C					6
2	GRD. BOLT	S45C					5
4	T/B + FRAME BOLT	S45C					4
4	T/B + COVER BOLT	S45C					3
1	TERMINAL BOX COVER	FC15					2
1	TERMINAL BOX ASSEMBLY	FC15					1

APPD BY	UNIT	MATERIAL	DIMENSION	WEIGHT	PART NO.	REMARK	NO.
CHKD BY	SCALE	N/S					
CHKD BY	PROJEC'N	3*4# (3rd Angle)					
DSND BY	DATE	99.2.2					
DESIGNED BY		LEE E.J.					
TITLE				MAIN TERMINAL BOX			
SUBJECT		IEC200FR 42G4		CAD PROJ. FILE		XSMOUT\7B1468LB	
REF. NO.		7B1470LA		Sheet No.		of	
DWG NO.		227B1470LA		Revision No.		0	

REV	DATE	CONTENTS	REV'D BY	CHK'D BY	APP'D BY
1					
2					
3					
4					



HYUNDAI HEAVY INDUSTRIES CO. LTD.
ELECTRICAL ENGINEERING DIVISION