

AC INDUCTION MOTOR DATA SHEET

Model No.or RFQ No.		Item No.		Rev. No. [0]			
Project Name		Project No.		Quantity sets			
GENERAL SPECIFICATION			PERFORMANCE DATA				
Frame Size	200LL		Rated Output	45 kW 60 HP			
Type	HLP-45/4		Number of Poles	4			
Enclosure(Protection)	Totally Enclosed (IP55)		Rotor Type	Squirrel Cage			
Method of Cooling	IC411(FC)		Starting Method*	<input checked="" type="checkbox"/> D.O.L <input type="checkbox"/> Y- Δ			
Rated Frequency	60 Hz		Rated Voltage	440 V	380 V 220 V		
Number of Phases	3		Current	Full Load	75.8 A 87.8 A 151.6 A		
Insulation Class	<input checked="" type="checkbox"/> F <input type="checkbox"/> B <input type="checkbox"/> H			Locked-rotor**	745 % 745 % 745 %		
Temp. Rise at full load (by resistance method)			Efficiency				
at 1.0 S.F 80 deg. C			50% Load 93.2 %				
Motor Location <input checked="" type="checkbox"/> Indoor <input type="checkbox"/> Outdoor			75% Load 95.1 %				
Altitude Less than 1000 meter			100% Load 95.0 %				
Relative Humidity Less than 80 %			Power Factor(p.u)				
Ambient Temp. 40 deg. C (Max.)			50% Load 0.740				
Duty Type Continuous (S1)			75% Load 0.795				
Service Factor 1.15			100% Load 0.820				
Mounting <input checked="" type="checkbox"/> B3 <input type="checkbox"/> B5 <input type="checkbox"/> V1 <input type="checkbox"/> B3/B5			Speed at Full Load 1775 r.p.m				
Bearing	Type	Anti-Friction		Torque			
	DE/N-DE	6313ZC3 / 6211ZC3		Full Load	24.7 kg·m		
	Lubricant	Grease(Gadus S2 V 100 2)		Locked-rotor**	150 %		
External Thrust Not applicable			Breakdown** 210 %				
Coupling Method <input checked="" type="checkbox"/> Direct <input type="checkbox"/> V-Belt			Moment of Inertia (J)				
Shaft Extension <input checked="" type="checkbox"/> Single <input type="checkbox"/> Double			Load(Max.) 26.000 kg·m ²				
Terminal Box	Main	<input type="checkbox"/> Steel <input checked="" type="checkbox"/> Cast Iron		Motor 0.546 kg·m ²			
	Aux.	<input type="checkbox"/> Yes <input checked="" type="checkbox"/> No		Sound Pressure Level (No-load & mean value at 1m from motor)			
Location Refer to Outline Drawing			78 dB(A)				
Application			Vibration 2.2 mm/sec (r.m.s)				
Area classification Non-Hazardous			Permissible number of consecutive starts				
Type of Ex-Protection Not applicable			Cold 3 times				
Applicable Standard KS,IEC, NEMA MG1 Part30(Vpeak)			Hot 2 times				
			Paint Munsell No. 4.4PB5.5/5.6(VL-451)				
ACCESSORIES			SUBMITTAL DRAWING				
			Outline Dimension Drawing \ Motor Weight(Approx.)				
			B3	LM-T1207B3PL001	320 kg		
			B5	LM-T1207B5PL001	330 kg		
			V1	LM-T1207V1PL001	330 kg		
			B3/B5	LM-T1207B4PL001	330 kg		
			Main T-Box Ass'y			3M-145864	
SPARE PARTS			REMARK				
			Premium Efficiency				
			*. For use on PWM VFD 10:1VT, 3:1CT@1.0S.F&F Temp. rise				
			Date	DSND	CHKD	CHKD	APPD
			2015-09-05	R.G. KIM	-	O.J. KIM	S.H. GO

Note: Others not mentioned in this data sheet shall be in accordance with maker standard.
 Above technical data are only design values and shall be guaranteed with tolerance of applicable standard.
 Inspection and performance test shall be maker standard, if not mentioned.
 * In case of Inverter-Fed Motor, performance data is based on sine wave tests.
 ** Data is based on when the motor is supplied at rated voltage & frequency, and the data is expressed as a percentage of full-load value.

Type	:	HLP-45/4
Full Load Torque	:	24.7 Kg.m
Motor moment of Inertia (J)	:	0.546 Kg.m ²
Load moment of Inertia (J)	:	26.000 Kg.m ²

45 kW	4 P	60 Hz	
Speed at Full Load :		1775 RPM	
Rated Voltage	440V	380V	220V
Full Load Current	75.8A	87.8A	151.6A

SPEED VS TORQUE & CURRENT CURVE

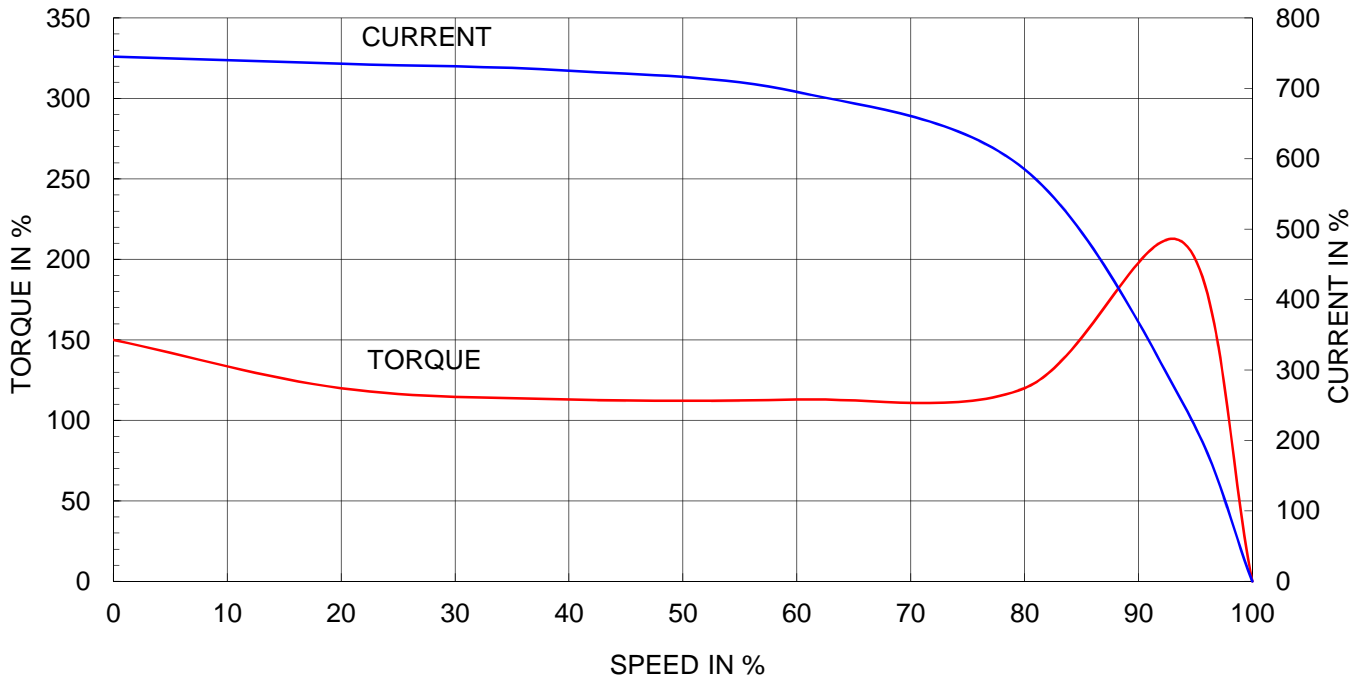

OUTPUT VS EFF., P.F & CURRENT CURVE

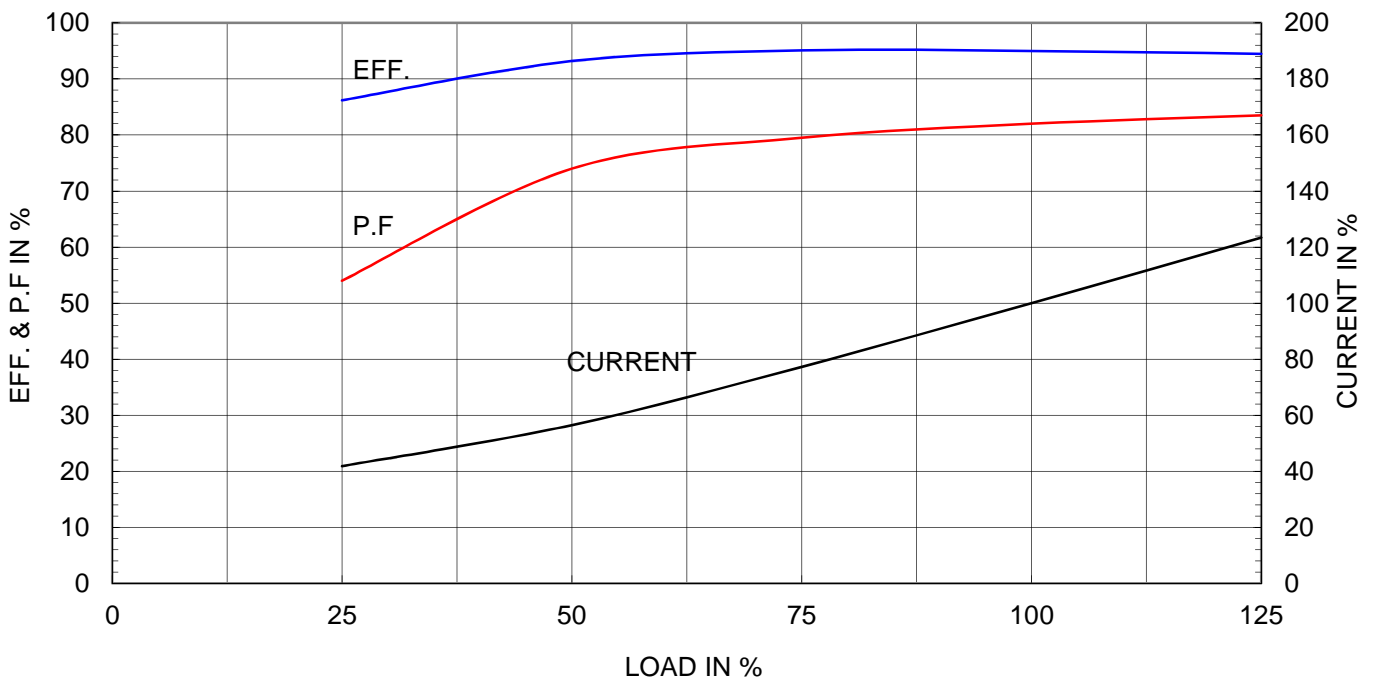



TEFC

THREE PHASE INDUCTION MOTOR

TYPE

HL, HS

CAST IRON FRAME

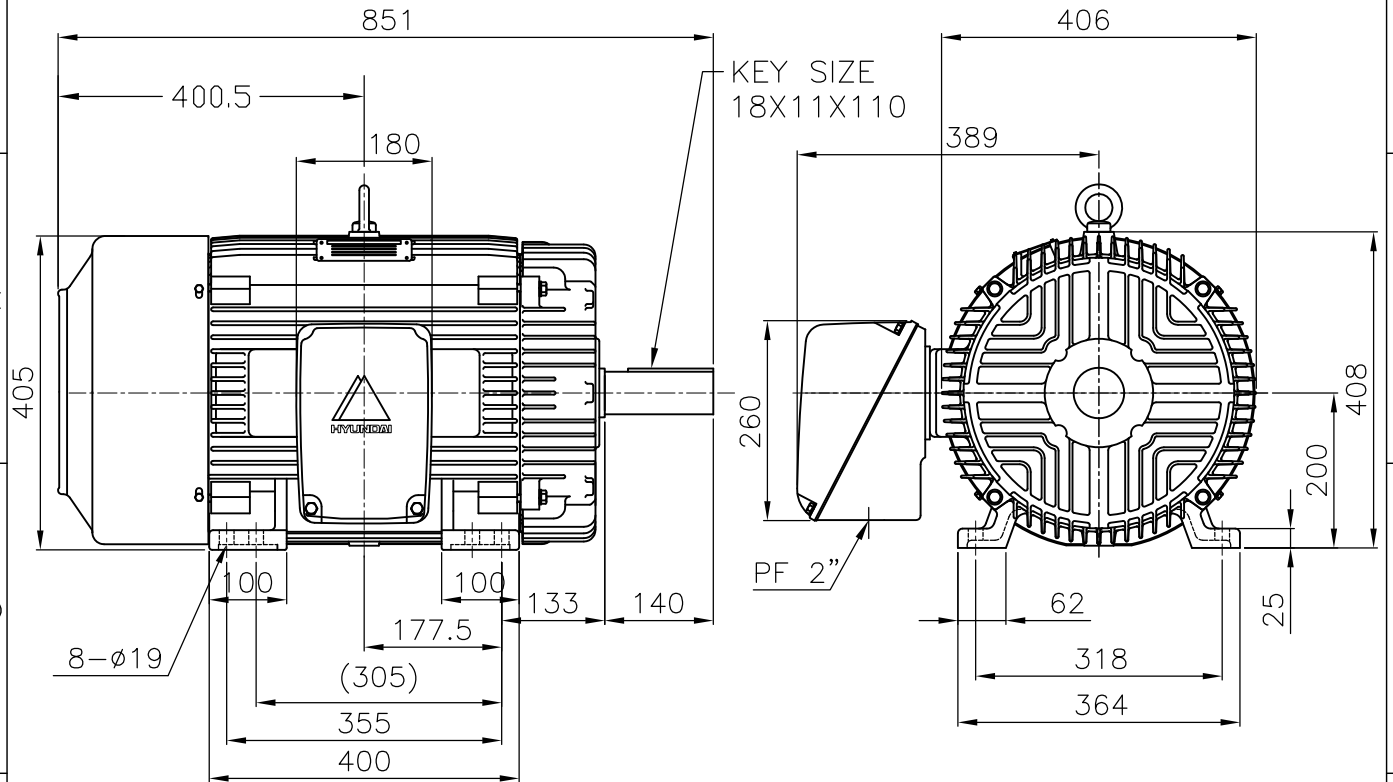

NOTE

1.TOLERANCE :

CENTER HEIGHT	200	⁺⁰ / _{-0.5}
BASE HOLES	ø19	^{+0.43} / ₋₀
SHAFT DIAMETER	ø60	^{+0.030} / _{+0.011}
KEYWAY WIDTH	18	⁺⁰ / _{-0.043}
KEYWAY DEPTH	7	^{+0.2} / ₊₀

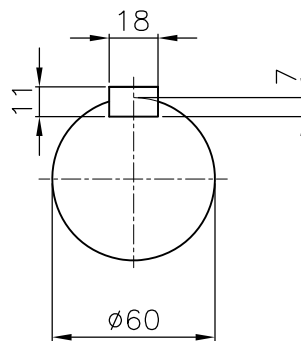

* STEEL CONDUIT BOX

APPD BY	J. H. KIM	UNIT	mm	SUBJECT	KS 200LL 4,6P	CAD PROJ \ FILE
CHKD BY	K. S. LEE	SCALE	1/10			XSDNKS\B2000AB10
CHKD BY	I. K. KIM	PROJEC'N	3rd Angle	TITLE OUTLINE		
DSND BY	S. M. KIM	DATE	2002.10.31			
				REF. NO	B2000AB12	Sheet No. of
				DWG NO	LM-T1207B3PL001	Revision No. 1

본 도면은 현대중공업(주) 재산이므로
허가없이 복사할 수 없음 (취급유의)

THIS DRAWING IS PROPRIETARY TO HHI. NO PART OF THIS DRAWING
MAYBE REPRODUCED WITHOUT THE PERMISSION OF HHI.

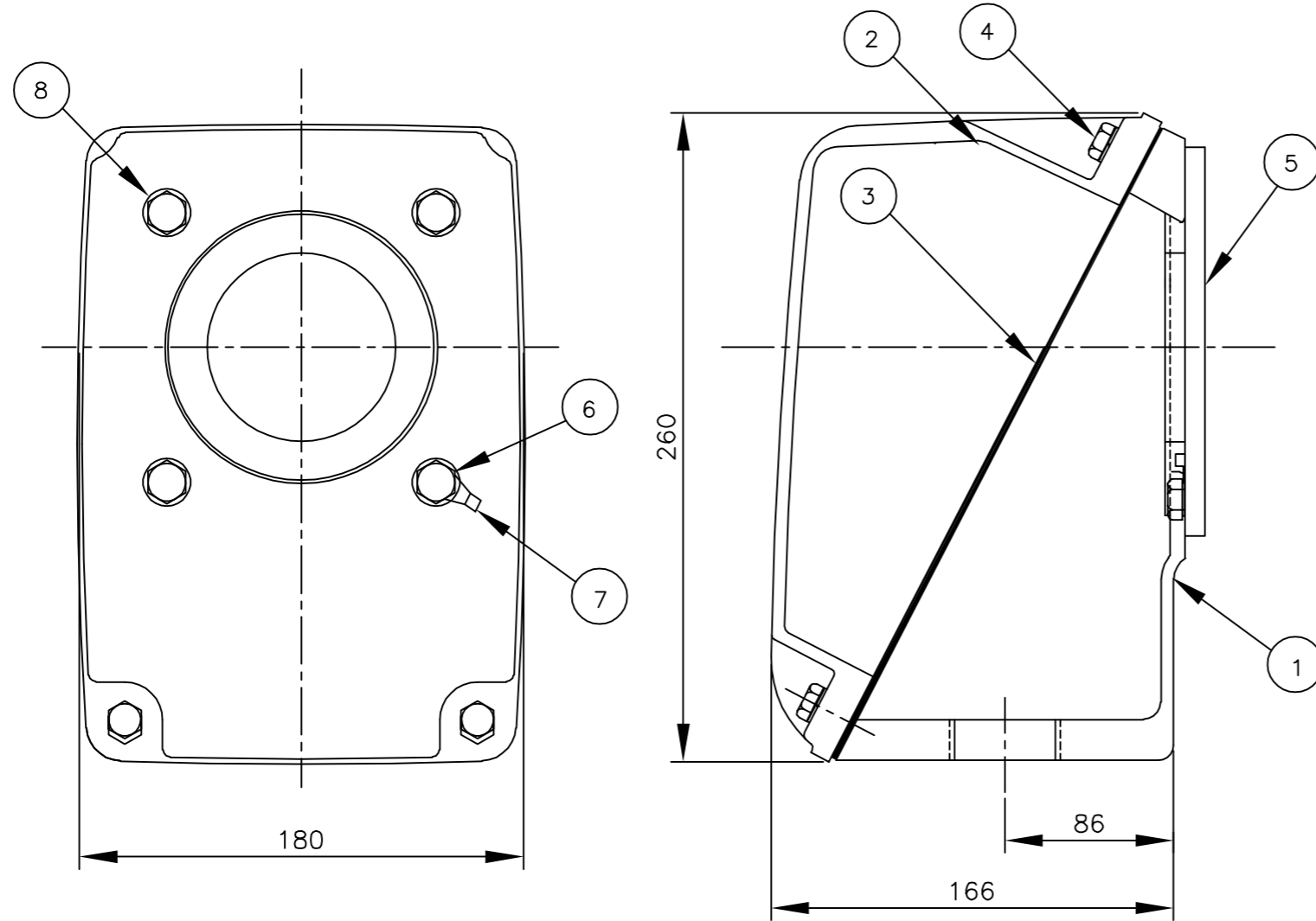

PT	DESCRIPTION	MATERIAL	DIMENSION	Q,TY
1	CONDUIT BOX	FC20		1
2	C/B COVER	FC20		1
3	GASKET(COVER)	N.B.R	T2X170X210	1
4	SCREW(COVER)	S45C	M8XL20	4
5	GASKET(C/B)	N.B.R		1
6	SCREW(C/B)	S45C	M8XL20	4
7	TERMINAL GROUND	CU	T1.6	1
8	WASHER	S45C	M8 X L10	4

▽	50S
▽▽	12.5S
▽▽▽	3.2S
▽▽▽▽	0.4S

REV	DATE	CONTENTS	REVD BY	CHKD BY	CHKD BY	APPD BY
1	12.01.27	CABLE 및 TAP 표시 삭제.	김양규	김옥진	김진홍	강경중

일반가공공차		일반제관공차	
1-4	±0.1	6-30	±0.5
4-18	±0.2	30-120	±0.8
18-63	±0.3	120-315	±1.2
63-250	±0.5	315-1000	±2.0
250-	±0.8	1000-	±3.0

Q'TY	DESCRIPTION	MATERIAL	DIMENSION	WEIGHT	PART NO.	REMARK	NO.
APPD BY	강경중	UNIT	mm	SUBJECT	IEC-Fr.200		DWG SIZE
CHKD BY	이노덕	SCALE	1/2	TITLE	Main Terminal Box Assembly		A3 (1:2)
CHKD BY	김인규	PROJEC'N	3각법(3rd Angle)	REF. NO	227B8003CB5	Sheet No.	of
DSND BY	김은성	DATE	2011-08-30	DWG NO	3M-145864	Revision No.	1