

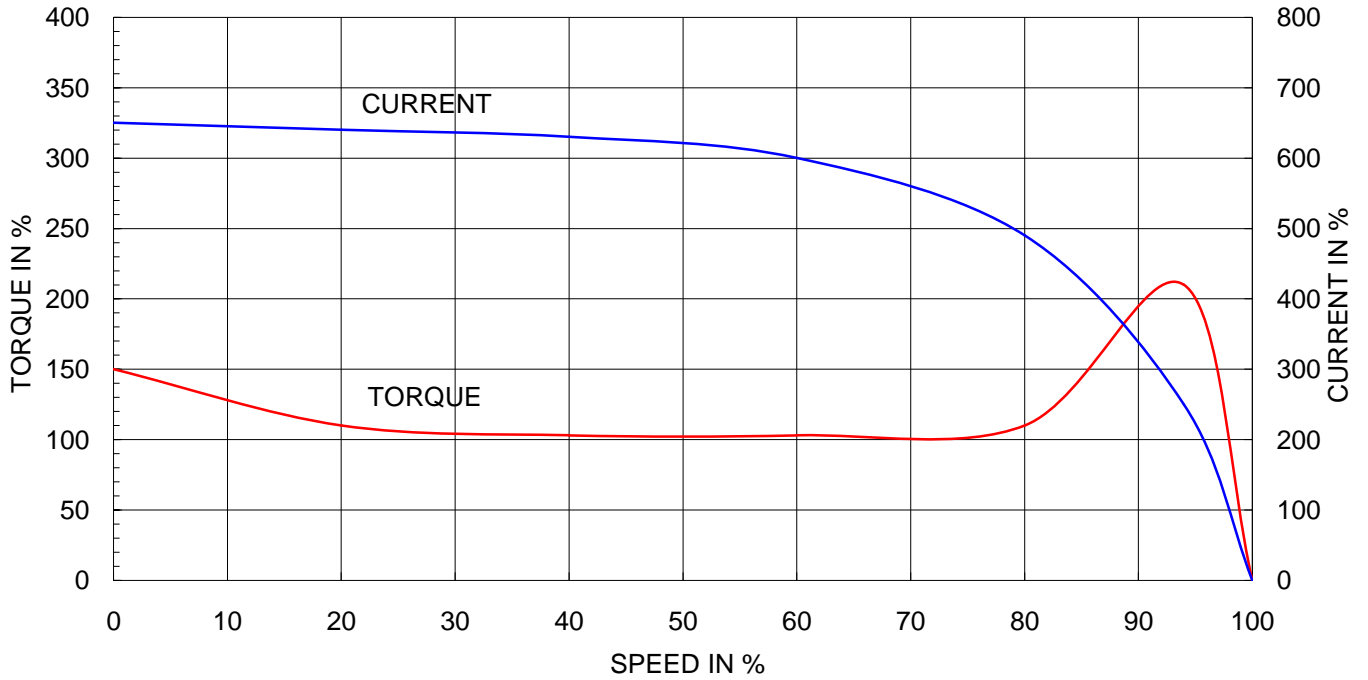

Type	:	HL-XP
Full Load Torque	:	8.3 Kg.m
Motor moment of Inertia (J)	:	0.088 Kg.m <sup>2</sup>
Load moment of Inertia (J)	:	3.000 Kg.m <sup>2</sup>

30 kW	2 P	60 Hz	
Speed at Full Load :		3540 RPM	
Rated Voltage	440V	380V	220V
Full Load Current	47.2A	54.6A	94.3A

SPEED VS TORQUE & CURRENT CURVE



OUTPUT VS EFF., P.F & CURRENT CURVE

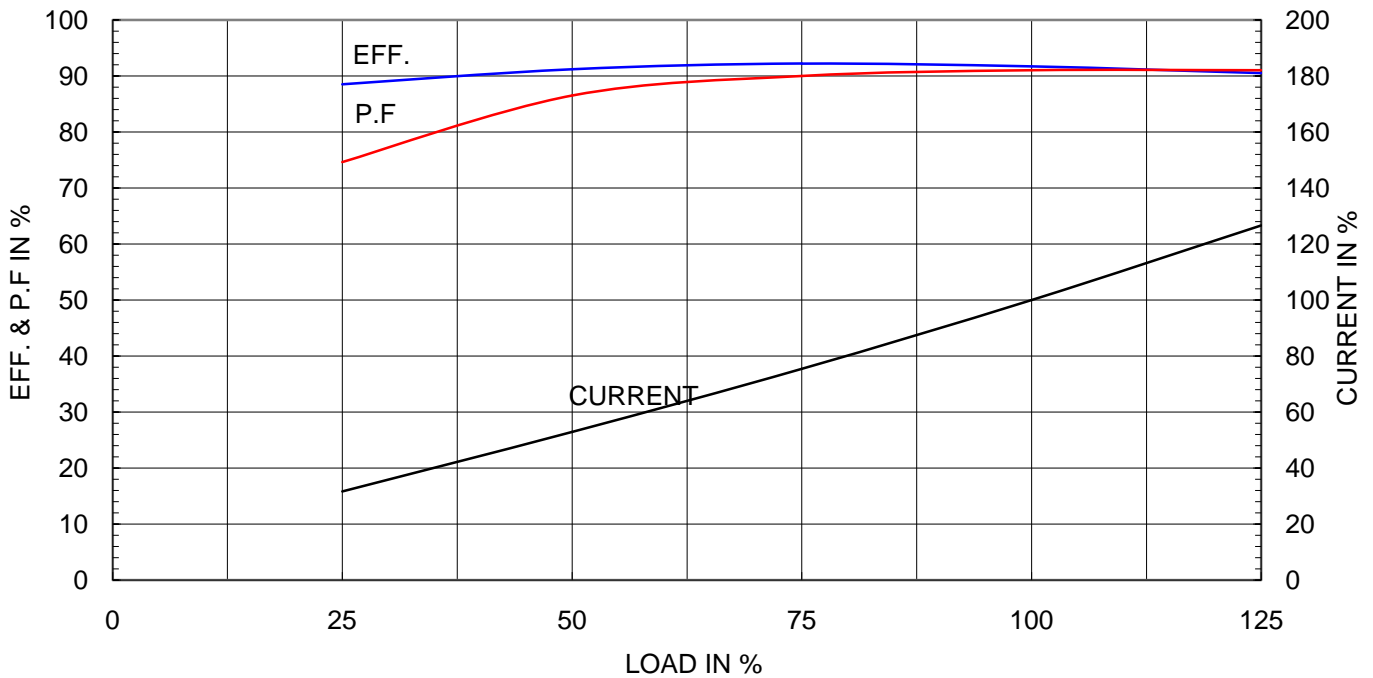



# TEFC

THREE PHASE INDUCTION MOTOR

TYPE

HL, HLS

CAST IRON FRAME

## Exd II

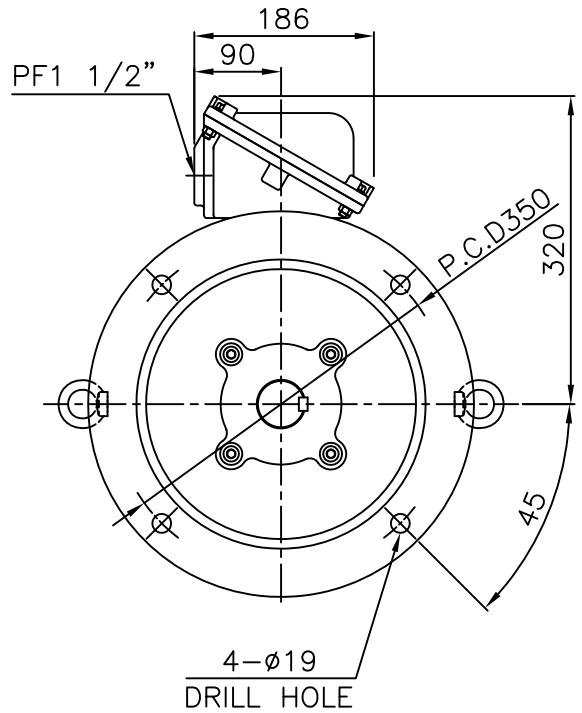
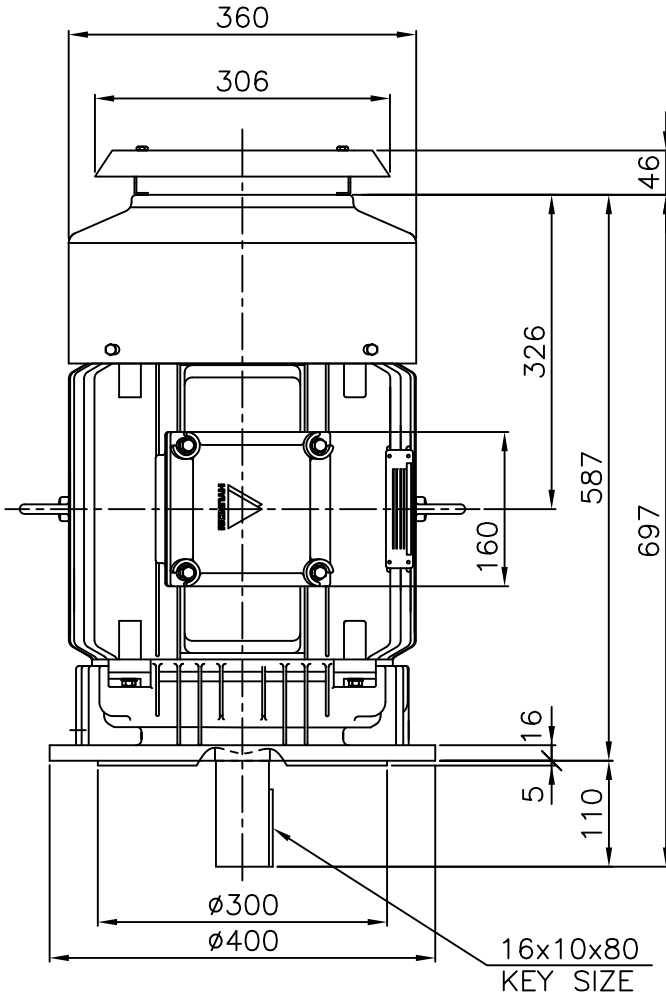

**NOTE**

1.TOLERANCE :

FLANGE HOLES	Ø19	+0.43	0
RABBET DIAMETER	Ø300	+0.016	-0.013
SHAFT DIAMETER	Ø55	+0.030	+0.011
KEYWAY WIDTH	16	0	-0.043
KEYWAY DEPTH	6	+0.2	0

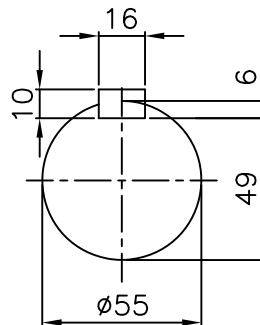

APPD BY	Y. S. KIM	UNIT	mm
CHKD BY	K. S. LEE	SCALE	1/8
CHKD BY	-----	PROJEC'N	3rd Angle
DSND BY	I. K. KIM	DATE	2008.10.22

SUBJECT	KS 180L	CAD PROJ \ FILE	XSDNKS\B2062AA08
TITLE	OUTLINE		

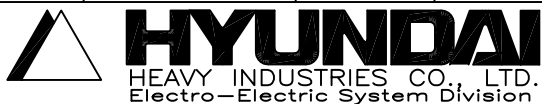

REF. NO	B2062AA08	Sheet No.	of
DWG NO	227B2062AA08	Revision No.	0

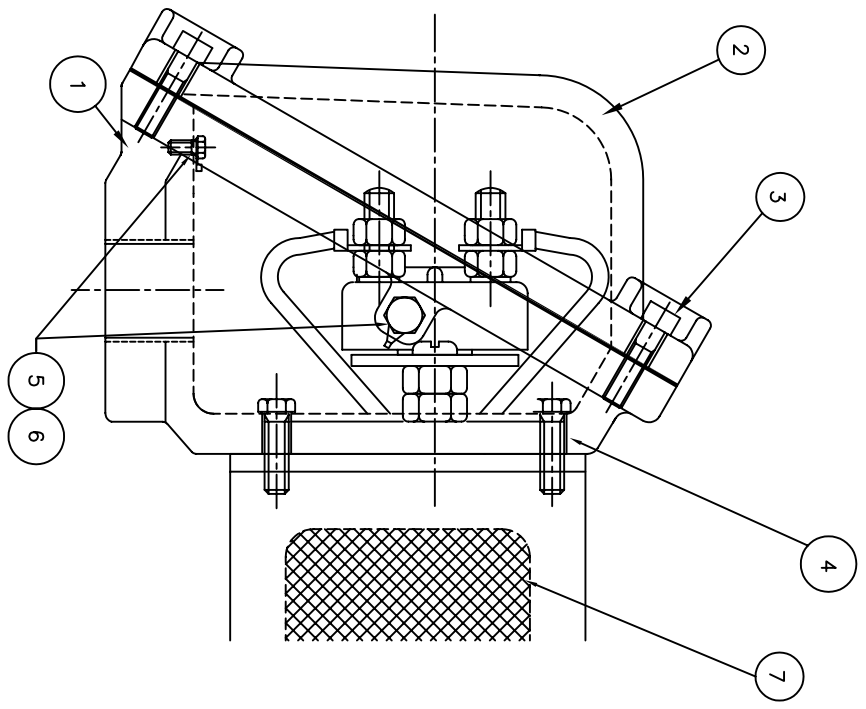
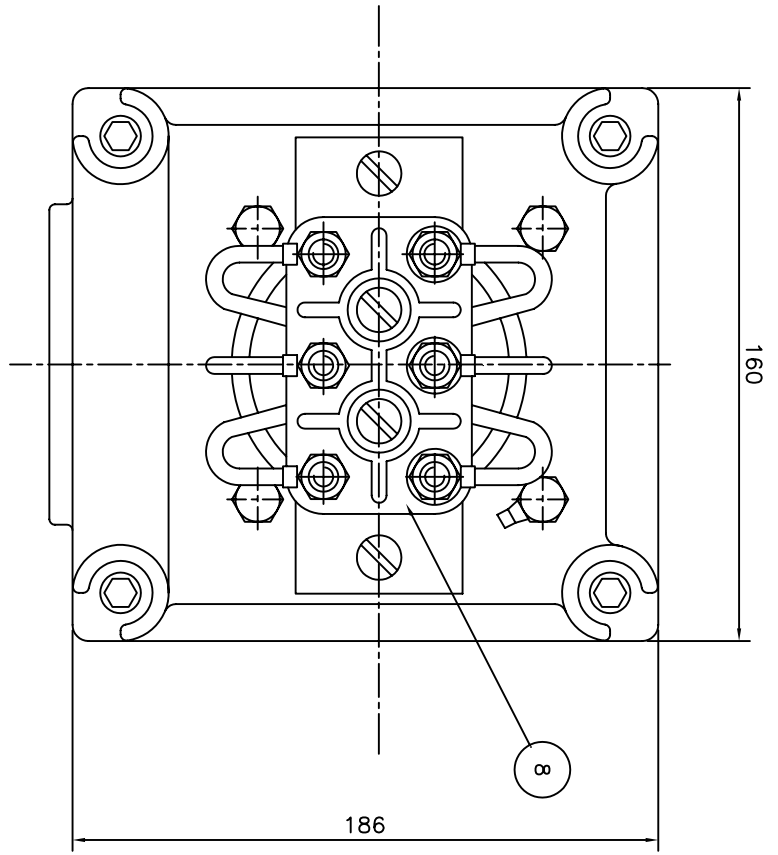

Q'TY	DESCRIPTION	MATERIAL	DIMENSION	WEIGHT	PART NO.	REMARK	NO.
1	TERMINAL BLOCK	D4C29C					8
1	SEALING COMPOUND	CU					7
2	GRD. TERMINAL LUG	S45C					6
2	GRD. BOLT	S45C					5
4	T/B + FRAME BOLT	S45C					4
4	T/B + COVER BOLT	S45C					3
1	TERMINAL BOX COVER	FC15					2
1	TERMINAL BOX ASSEMBLY	FC15					1

APPD BY	UNIT	MATERIAL	DIMENSION	WEIGHT	PART NO.	REMARK	NO.
CHKD BY	SCALE	N/S					
CHKD BY	PROJEC'N	3*4# (3rd Angle)					
DSND BY	DATE	99.2.2					
DSND BY	LEE E.J.						
TITLE		MAIN TERMINAL BOX					
REF. NO	7B1470LB		SHEET NO.		0		
DWG NO	227B1470LB		REVISION NO.		0		

REV	DATE	CONTENTS	REV'D BY	CHK'D BY	APP'D BY
1					
2					
3					
4					



HYUNDAI HEAVY INDUSTRIES CO., LTD.  
ELECTRICAL ENGINEERING DIVISION