

AC INDUCTION MOTOR DATA SHEET

Model No. or RFQ No.		Item No.		Rev. No. [0]			
Project Name		Project No.		Quantity sets			
GENERAL SPECIFICATION			PERFORMANCE DATA				
Frame Size	180M		Rated Output	22 kW	30 HP		
Type	HL-XP		Number of Poles	4			
Enclosure(Protection)	Explosion Proof (IP55)		Rotor Type	Squirrel Cage			
Method of Cooling	IC411(FC)		Starting Method*	<input checked="" type="checkbox"/> D.O.L <input type="checkbox"/> Y- Δ			
Rated Frequency	60 Hz		Rated Voltage	440 V	380 V 220 V		
Number of Phases	3		Current	Full Load	37.6 A 43.6 A 75.3 A		
Insulation Class	<input checked="" type="checkbox"/> F <input type="checkbox"/> B <input type="checkbox"/> H		Locked-rotor**	650 %	650 % 650 %		
Temp. Rise at full load (by resistance method)			Efficiency				
at 1.0 S.F 80 deg. C			50% Load 91.9 %				
Motor Location	<input checked="" type="checkbox"/> Indoor <input type="checkbox"/> Outdoor		75% Load 92.6 %				
Altitude	Less than 1000 meter		100% Load 92.4 %				
Relative Humidity	Less than 80 %		Power Factor(p.u)				
Ambient Temp.	40 deg. C (Max.)		50% Load 0.722				
Duty Type	Continuos (S1)		75% Load 0.790				
Service Factor	1.00		100% Load 0.830				
Mounting	<input checked="" type="checkbox"/> B3 <input type="checkbox"/> B5 <input type="checkbox"/> V1 <input type="checkbox"/> B3/B5		Speed at Full Load	1775 r.p.m			
Bearing	Type	Anti-Friction		Torque			
	DE/N-DE	6310ZZC3 / 6310ZZC3		Full Load	12.1 kg·m		
	Lubricant	Grease(Polyrex-EM)		Locked-rotor**	160 %		
External Thrust	Not applicable		Breakdown**	230 %			
Coupling Method	<input checked="" type="checkbox"/> Direct <input type="checkbox"/> V-Belt		Moment of Inertia (J)				
Shaft Extension	<input checked="" type="checkbox"/> Single <input type="checkbox"/> Double		Load(Max.)	16.750 kg·m ²			
Terminal Box	Main	<input type="checkbox"/> Steel <input checked="" type="checkbox"/> Cast Iron		Motor	0.180 kg·m ²		
	Aux.	<input type="checkbox"/> Yes <input checked="" type="checkbox"/> No		Sound Pressure Level (No-load & mean value at 1m from motor)			
	Location	Refer to Outline Drawing		77 dB(A)			
Application			Vibration	2.2 mm/sec (r.m.s)			
Area classification	Hazardous		Permissible number of consecutive starts	Cold	3 times		
Type of Ex-Protection	Ex d IIB T4		Hot	2 times			
Applicable Standard	KS,IEC		Paint	Munsell No.	4.0PB5.4/5.5(VL-451)		
ACCESSORIES			SUBMITTAL DRAWING				
			Outline Dimension Drawing \ Motor Weight(Approx.)				
			B3	227B2002AA07	199 kg		
			B5		kg		
			V1		kg		
			B3/B5		0 kg		
			Main T-Box Ass'y	227B1470LB			
SPARE PARTS			REMARK				
			High Efficiency				
			Date	DSND	CHKD	CHKD	APPD
			2011-04-14	W.H.BACK	S. J. RA	O. J. KIM	J. H. KIM

Note: Others not mentioned in this data sheet shall be in accordance with maker standard.

Above technical data are only design values and shall be guaranteed with tolerance of applicable standard.

Inspection and performance test shall be maker standard, if not mentioned.

* In case of Inverter-Fed Motor, performance data is based on sine wave tests.

** Data is based on when the motor is supplied at rated voltage & frequency, and the data is expressed as a percentage of full-load value.

Type	:	HL-XP
Full Load Torque	:	12.1 Kg.m
Motor moment of Inertia (J)	:	0.180 Kg.m ²
Load moment of Inertia (J)	:	16.750 Kg.m ²

22 kW	4 P	60 Hz	
Speed at Full Load :		1775 RPM	
Rated Voltage	440V	380V	220V
Full Load Current	37.6A	43.6A	75.3A

SPEED VS TORQUE & CURRENT CURVE

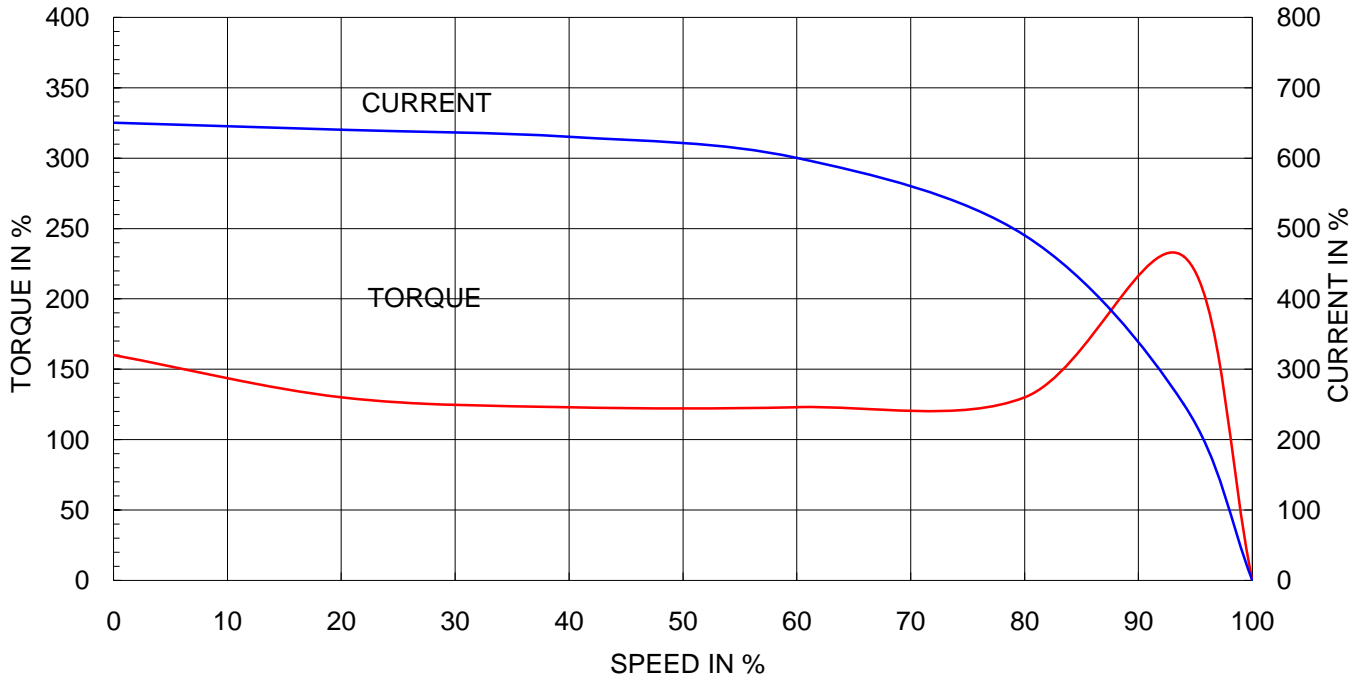

OUTPUT VS EFF., P.F & CURRENT CURVE

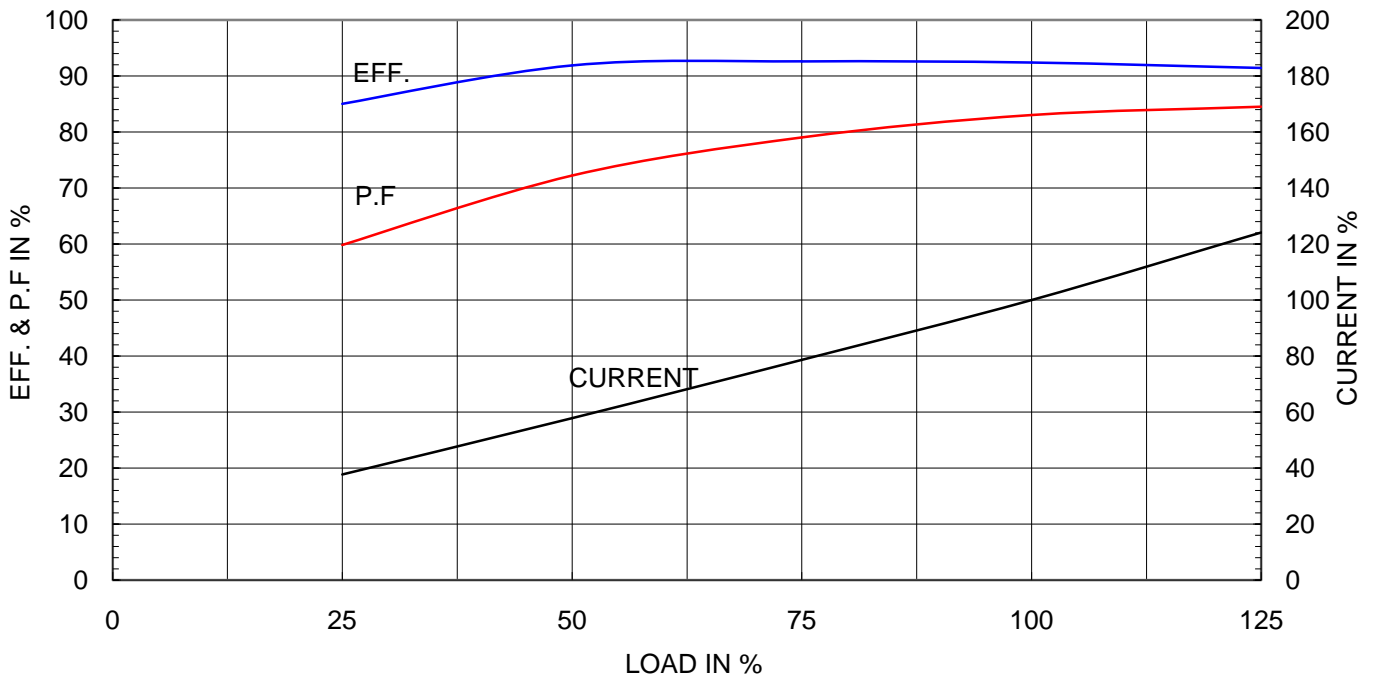

Exd II

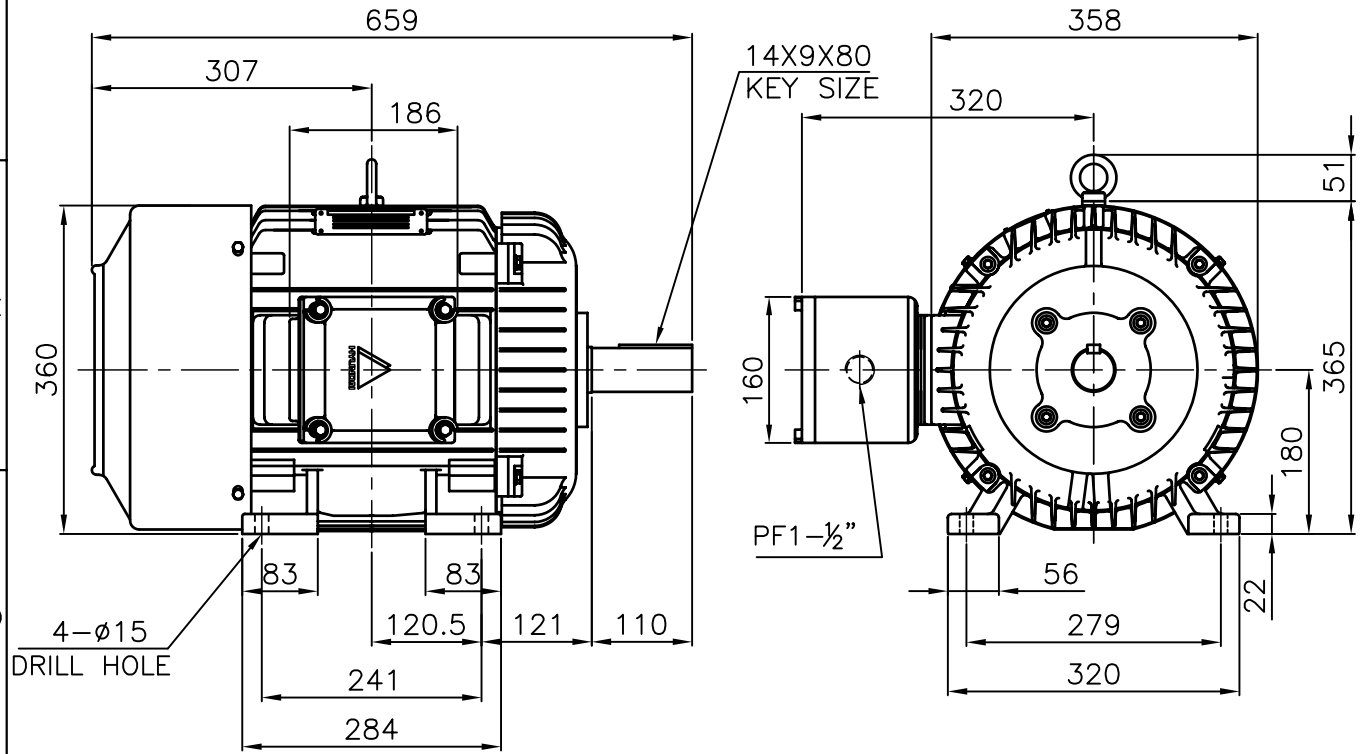

NOTE

1.TOLERANCE :

CENTER HEIGHT	180	$\begin{matrix} 0 \\ -0.5 \end{matrix}$
BASE HOLES	$\phi 15$	$\begin{matrix} +0.43 \\ 0 \end{matrix}$
SHAFT DIAMETER	$\phi 48$	$\begin{matrix} +0.018 \\ +0.002 \end{matrix}$
KEYWAY WIDTH	14	$\begin{matrix} 0 \\ -0.043 \end{matrix}$
KEYWAY DEPTH	5.5	$\begin{matrix} +0.2 \\ 0 \end{matrix}$

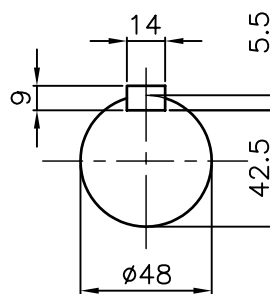

APPD BY	Y. S. KIM	UNIT	mm	SUBJECT	KS 180M	CAD PROJ \ FILE	XSDNKS\B2002AA07
CHKD BY	K. S. LEE	SCALE	1/8.5	TITLE	OUTLINE		
CHKD BY	-----	PROJEC'N	3rd Angle				
DSND BY	I. K. KIM	DATE	2008.10.22	REF. NO	B2002AA07	Sheet No.	of
				DWG NO	227B2002AA07	Revision No.	0

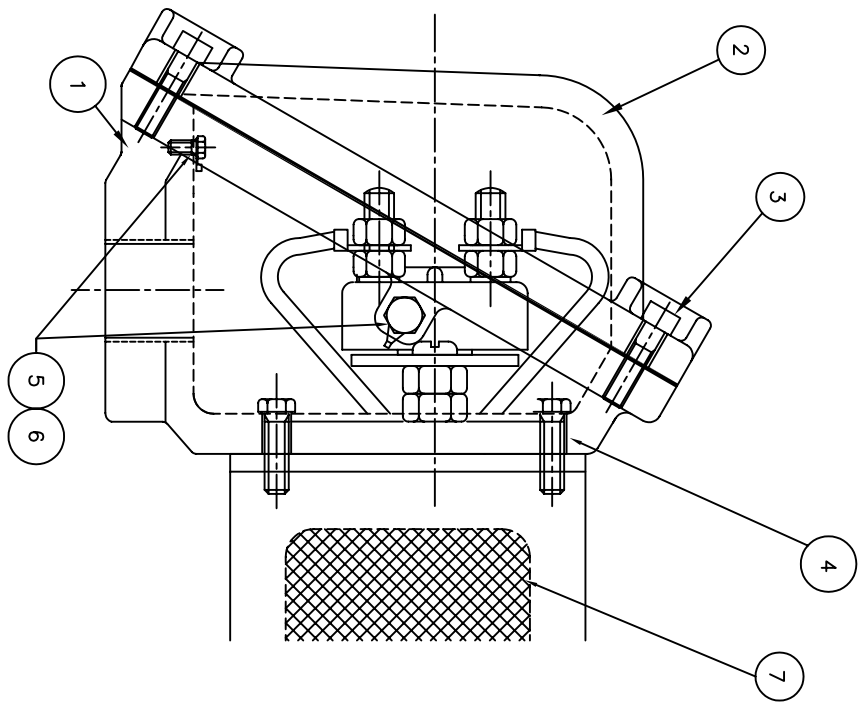
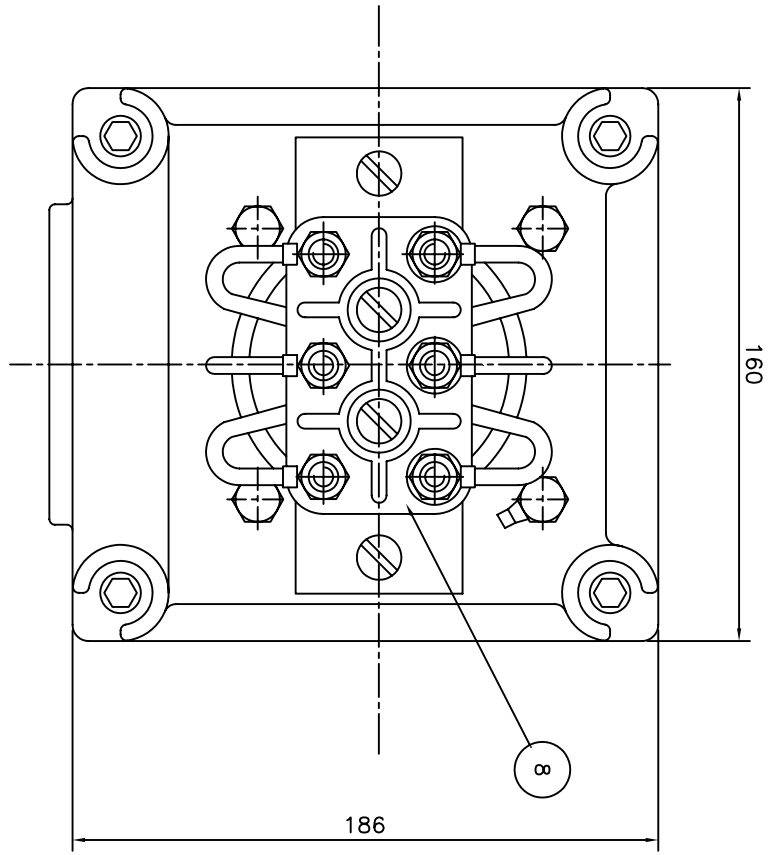

Q'TY	DESCRIPTION	MATERIAL	DIMENSION	WEIGHT	PART NO.	REMARK	NO.
1	TERMINAL BLOCK	D4C29C					8
1	SEALING COMPOUND	CU					7
2	GRD. TERMINAL LUG	S45C					6
2	GRD. BOLT	S45C					5
4	T/B + FRAME BOLT	S45C					4
4	T/B + COVER BOLT	S45C					3
1	TERMINAL BOX COVER	FC15					2
1	TERMINAL BOX ASSEMBLY	FC15					1

APPD BY	UNIT	MATERIAL	DIMENSION	WEIGHT	PART NO.	REMARK	NO.
CHKD BY	SCALE	N/S	SUBJECT	IEC 160/180FR d2G4		CAD PROJ \FILE XSMOUT\7B1468LB	
CHKD BY	PROJEC'N	3*4 (3rd Angle)	TITLE	MAIN TERMINAL BOX			
DSND BY	DATE	99.2.2	REF. NO	7B1470LB	Sheet No. of		
	LEE E.J.		DWG NO	227B1470LB	Revision No.	0	

REV	DATE	CONTENTS	REVD BY	CHKD BY	CHKD BY	APPD BY
1						
2						
3						
4						

HYUNDAI
HEAVY INDUSTRIES CO. LTD.
ELECTRICAL ENGINEERING DIVISION