



AC INDUCTION MOTOR DATA SHEET

Model No.or RFQ No.		Item No.		Rev. No. [0]			
Project Name		Project No.		Quantity sets			
GENERAL SPECIFICATION			PERFORMANCE DATA				
Frame Size	180L		Rated Output	18.5 kW 25 HP			
Type	HL-XP		Number of Poles	6			
Enclosure(Protection)	Explosion Proof (IP55)		Rotor Type	Squirrel Cage			
Method of Cooling	IC411(FC)		Starting Method*	<input checked="" type="checkbox"/> D.O.L <input type="checkbox"/> Y- Δ			
Rated Frequency	60 Hz		Rated Voltage	440 V	380 V 220 V		
Number of Phases	3		Current	Full Load	34.2 A 39.6 A 68.3 A		
Insulation Class	<input checked="" type="checkbox"/> F <input type="checkbox"/> B <input type="checkbox"/> H		Locked-rotor**	680 %	680 % 680 %		
Temp. Rise at full load (by resistance method)			Efficiency				
at 1.0 S.F 80 deg. C			50% Load 91.2 %				
Motor Location	<input type="checkbox"/> Indoor <input checked="" type="checkbox"/> Outdoor		75% Load 92.0 %				
Altitude	Less than 1000 meter		100% Load 91.7 %				
Relative Humidity	Less than 80 %		Power Factor(p.u)				
Ambient Temp.	40 deg. C (Max.)		50% Load 0.651				
Duty Type	Continuos (S1)		75% Load 0.736				
Service Factor	1.00		100% Load 0.775				
Mounting	<input type="checkbox"/> B3 <input type="checkbox"/> B5 <input checked="" type="checkbox"/> V1 <input type="checkbox"/> B3/B5		Speed at Full Load 1175 r.p.m				
Bearing	Type	Anti-Friction		Torque			
	DE/N-DE	6312ZZC3 / 6310ZZC3		Full Load 15.3 kg·m			
	Lubricant	Grease(Polyrex-EM)		Locked-rotor** 160 %			
External Thrust	Not applicable		Breakdown** 250 %				
Coupling Method	<input checked="" type="checkbox"/> Direct <input type="checkbox"/> V-Belt		Moment of Inertia (J)				
Shaft Extension	<input checked="" type="checkbox"/> Single <input type="checkbox"/> Double		Load(Max.) 33.000 kg·m ²				
Terminal Box	Main	<input type="checkbox"/> Steel <input checked="" type="checkbox"/> Cast Iron		Motor 0.257 kg·m ²			
	Aux.	<input type="checkbox"/> Yes <input checked="" type="checkbox"/> No		Sound Pressure Level (No-load & mean value at 1m from motor)			
	Location	Refer to Outline Drawing		68 dB(A)			
Application			Vibration 2.2 mm/sec (r.m.s)				
Area classification	Hazardous		Permissible number of consecutive starts				
Type of Ex-Protection	Ex d IIB T4		Cold 3 times				
Applicable Standard	KS,IEC		Hot 2 times				
ACCESSORIES			Paint Munsell No. 4.0PB5.4/5.5(VL-451)				
ACCESSORIES			SUBMITTAL DRAWING				
			Outline Dimension Drawing \ Motor Weight(Approx.)				
			B3			kg	
			B5			kg	
			V1		227B2062AA08	229 kg	
			B3/B5			0 kg	
			Main T-Box Ass'y 227B1470LB				
SPARE PARTS			REMARK High Efficiency				
			Date	DSND	CHKD	CHKD	APPD
			2011-04-14	W.H.BACK	S. J. RA	O. J. KIM	J. H. KIM
			Note: Others not mentioned in this data sheet shall be in accordance with maker standard. Above technical data are only design values and shall be guaranteed with tolerance of applicable standard. Inspection and performance test shall be maker standard, if not mentioned. * In case of Inverter-Fed Motor, performance data is based on sine wave tests. ** Data is based on when the motor is supplied at rated voltage & frequency. and the data is expressed as a percentage of full-load value.				

HHI W230-131-1 * In case of Inverter or V.V.V.F Motor:Performance data is based on sine wave tests. A4(210mm X 297mm)

Type	:	HL-XP
Full Load Torque	:	15.3 Kg.m
Motor moment of Inertia (J)	:	0.257 Kg.m ²
Load moment of Inertia (J)	:	33.000 Kg.m ²

18.5 kW	6 P	60 Hz	
Speed at Full Load :		1175 RPM	
Rated Voltage	440V	380V	220V
Full Load Current	34.2A	39.6A	68.3A

SPEED VS TORQUE & CURRENT CURVE

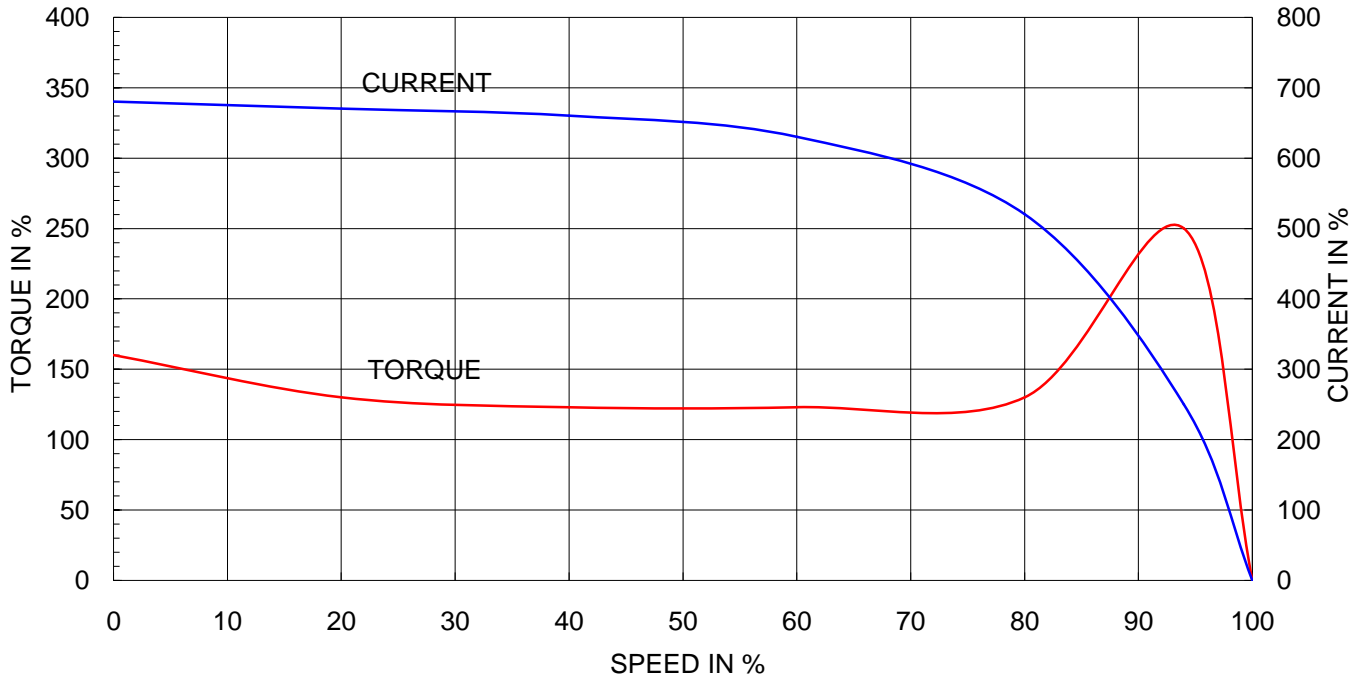

OUTPUT VS EFF., P.F & CURRENT CURVE

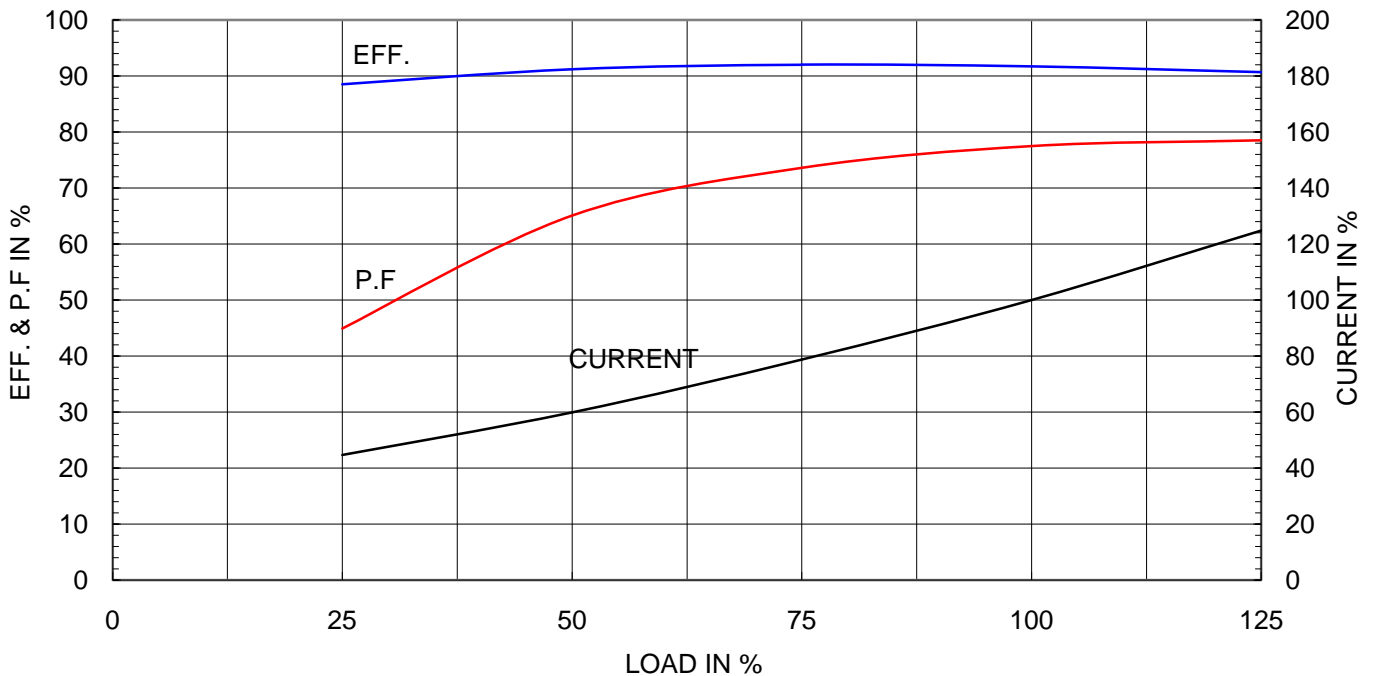



TEFC

THREE PHASE INDUCTION MOTOR

TYPE

HL, HLS

CAST IRON FRAME

Exd II

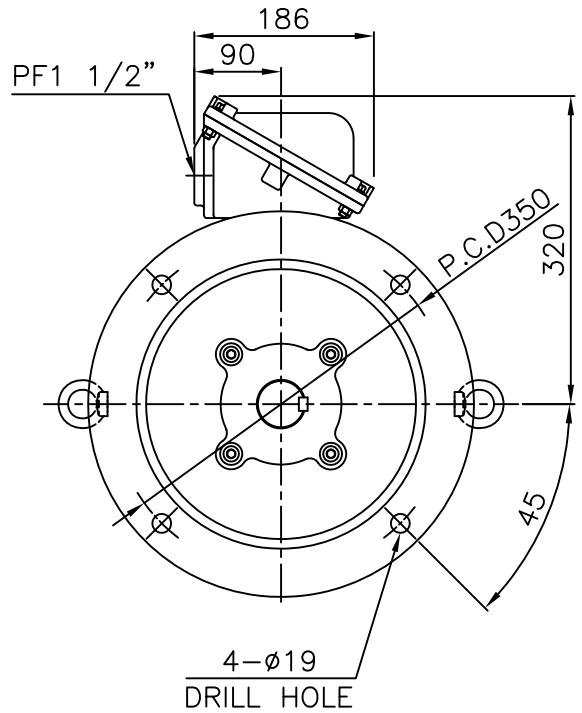
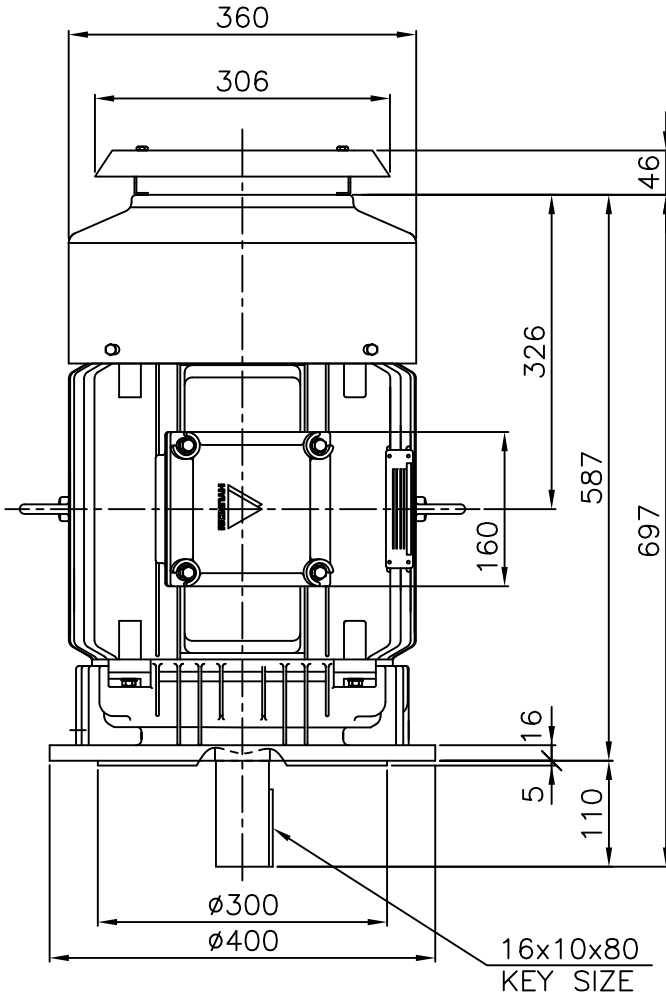

NOTE

1.TOLERANCE :

FLANGE HOLES	Ø19	+0.43	0
RABBET DIAMETER	Ø300	+0.016	-0.013
SHAFT DIAMETER	Ø55	+0.030	+0.011
KEYWAY WIDTH	16	0	-0.043
KEYWAY DEPTH	6	+0.2	0

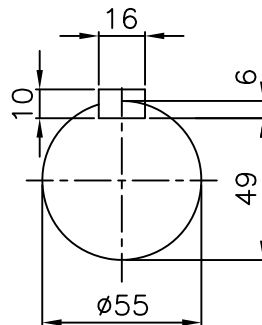

APPD BY	Y. S. KIM	UNIT	mm
CHKD BY	K. S. LEE	SCALE	1/8
CHKD BY	-----	PROJEC'N	3rd Angle
DSND BY	I. K. KIM	DATE	2008.10.22

SUBJECT	KS 180L	CAD PROJ \ FILE	XSDNKS\B2062AA08
---------	---------	-----------------	------------------

TITLE	OUTLINE		
-------	---------	--	--

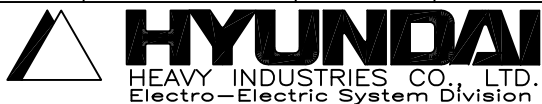

REF. NO	B2062AA08	Sheet No.	of
DWG NO	227B2062AA08	Revision No.	0

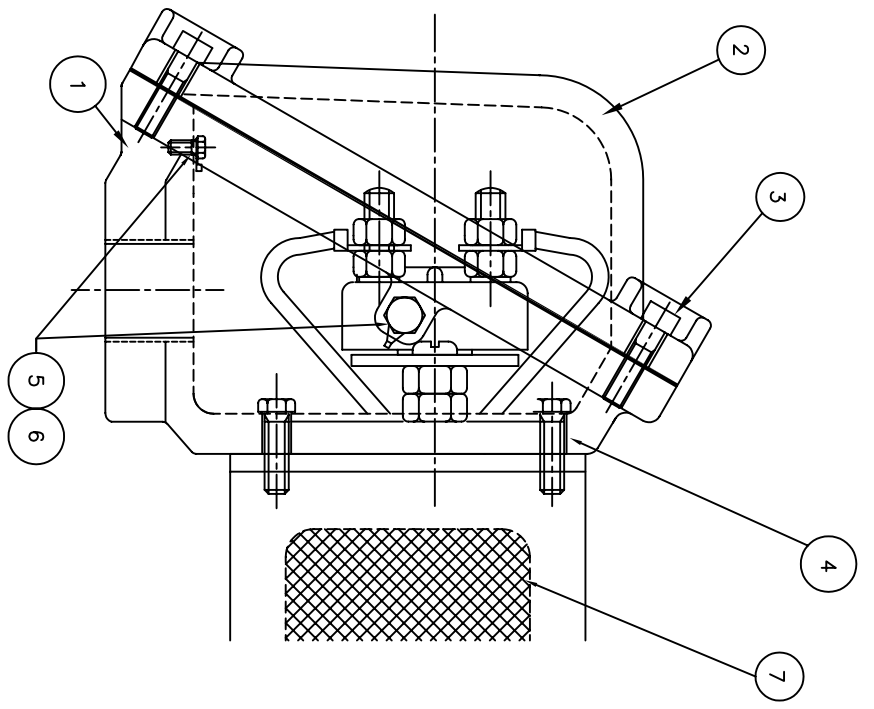
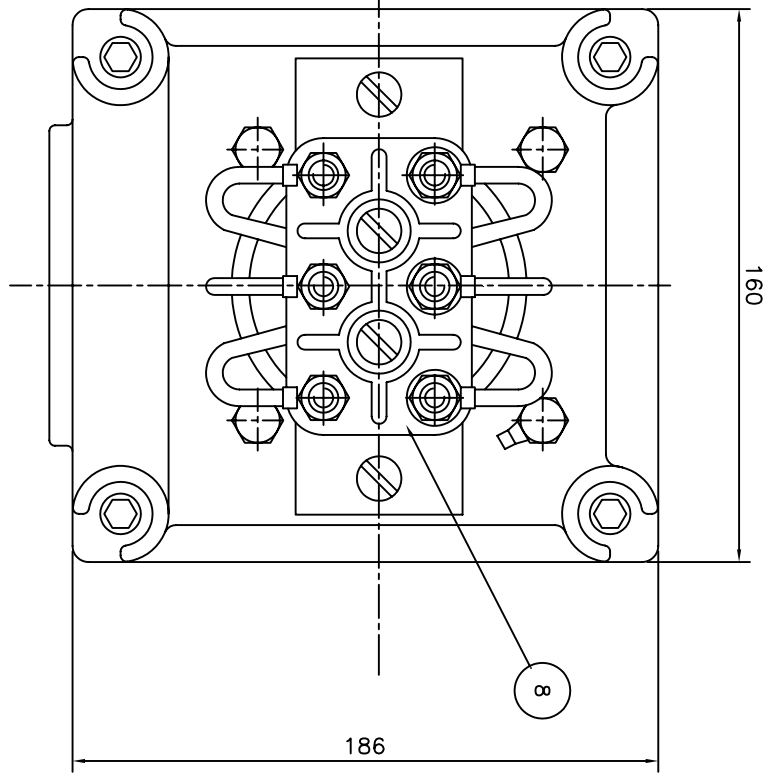

REV	DATE	CONTENTS	REV'D BY	CHK'D BY	CHK'D BY	APP'D BY
1						
2						
3						
4						

Q'TY	DESCRIPTION	MATERIAL	DIMENSION	WEIGHT	PART NO.	REMARK	NO.
1	TERMINAL BLOCK	D4C29C					8
1	SEALING COMPOUND	CU					7
2	GRD TERMINAL LUG	S45C					6
2	GRD. BOLT	S45C					5
4	T/B + FRAME BOLT	S45C					4
4	T/B + COVER BOLT	S45C					3
1	TERMINAL BOX COVER	FC15					2
1	TERMINAL BOX ASSEMBLY	FC15					1

APP'D BY	UNIT	MM	SUBJECT	IEC 160/180FR d2G4	CAD PROJ \FILE
CHK'D BY	SCALE	N/S	TITLE	MAIN TERMINAL BOX	XSMOUT\7B1468LB
CHK'D BY	PROJEC'N	3*4 (3rd Angle)	REF. NO	7B1470LB	Sheet No. of
DSND BY	LEE E.J.	DATE	99.2.2	DWG NO	227B1470LB
					Revision No. 0



HEAVY INDUSTRIES CO. LTD.
ELECTRICAL ENGINEERING DIVISION