



AC INDUCTION MOTOR DATA SHEET

Model No.or RFQ No.		Item No.		Rev. No. [0]		
Project Name		Project No.		Quantity sets		
GENERAL SPECIFICATION			PERFORMANCE DATA			
Frame Size	180M		Rated Output	15 kW 20 HP		
Type	HL-XP		Number of Poles	6		
Enclosure(Protection)	Explosion Proof (IP55)		Rotor Type	Squirrel Cage		
Method of Cooling	IC411(FC)		Starting Method*	<input checked="" type="checkbox"/> D.O.L <input type="checkbox"/> Y- Δ		
Rated Frequency	60 Hz		Rated Voltage	440 V	380 V 220 V	
Number of Phases	3		Current	Full Load	28.9 A 33.5 A 57.8 A	
Insulation Class	<input checked="" type="checkbox"/> F <input type="checkbox"/> B <input type="checkbox"/> H		Locked-rotor**	650 %	650 % 650 %	
Temp. Rise at full load (by resistance method)			Efficiency			
at 1.0 S.F 80 deg. C			50% Load 89.7 %			
Motor Location	<input type="checkbox"/> Indoor <input checked="" type="checkbox"/> Outdoor		75% Load 90.5 %			
Altitude	Less than 1000 meter		100% Load 90.2 %			
Relative Humidity	Less than 80 %		Power Factor(p.u)			
Ambient Temp.	40 deg. C (Max.)		50% Load 0.626			
Duty Type	Continuos (S1)		75% Load 0.712			
Service Factor	1.00		100% Load 0.755			
Mounting	<input type="checkbox"/> B3 <input type="checkbox"/> B5 <input checked="" type="checkbox"/> V1 <input type="checkbox"/> B3/B5		Speed at Full Load 1175 r.p.m			
Bearing	Type	Anti-Friction		Torque		
	DE/N-DE	6310ZZC3 / 6310ZZC3		Full Load 12.4 kg·m		
	Lubricant	Grease(Polyrex-EM)		Locked-rotor** 150 %		
External Thrust	Not applicable		Breakdown** 230 %			
Coupling Method	<input checked="" type="checkbox"/> Direct <input type="checkbox"/> V-Belt		Moment of Inertia (J)			
Shaft Extension	<input checked="" type="checkbox"/> Single <input type="checkbox"/> Double		Load(Max.) 26.500 kg·m ²			
Terminal Box	Main	<input type="checkbox"/> Steel <input checked="" type="checkbox"/> Cast Iron		Motor 0.210 kg·m ²		
	Aux.	<input type="checkbox"/> Yes <input checked="" type="checkbox"/> No		Sound Pressure Level (No-load & mean value at 1m from motor)		
	Location	Refer to Outline Drawing		68 dB(A)		
Application			Vibration 2.2 mm/sec (r.m.s)			
Area classification	Hazardous		Permissible number of consecutive starts			
Type of Ex-Protection	Ex d IIB T4		Cold 3 times			
Applicable Standard	KS,IEC		Hot 2 times			
ACCESSORIES			Paint Munsell No. 4.0PB5.4/5.5(VL-451)			
ACCESSORIES			SUBMITTAL DRAWING			
			Outline Dimension Drawing \ Motor Weight(Approx.)			
			B3		kg	
			B5		kg	
			V1	227B2062AA07	211 kg	
			B3/B5		0 kg	
			Main T-Box Ass'y 227B1470LB			
SPARE PARTS			REMARK High Efficiency			
			Date	DSND	CHKD	
			2011-04-14	W.H.BACK	S. J. RA	
			CHKD	APPD		
			O. J. KIM	J. H. KIM		

Note: Others not mentioned in this data sheet shall be in accordance with maker standard.
 Above technical data are only design values and shall be guaranteed with tolerance of applicable standard.
 Inspection and performance test shall be maker standard, if not mentioned.
 * In case of Inverter-Fed Motor, performance data is based on sine wave tests.
 ** Data is based on when the motor is supplied at rated voltage & frequency, and the data is expressed as a percentage of full-load value.

Type	:	HL-XP
Full Load Torque	:	12.4 Kg.m
Motor moment of Inertia (J)	:	0.210 Kg.m ²
Load moment of Inertia (J)	:	26.500 Kg.m ²

15 kW	6 P	60 Hz	
Speed at Full Load :		1175 RPM	
Rated Voltage	440V	380V	220V
Full Load Current	28.9A	33.5A	57.8A

SPEED VS TORQUE & CURRENT CURVE

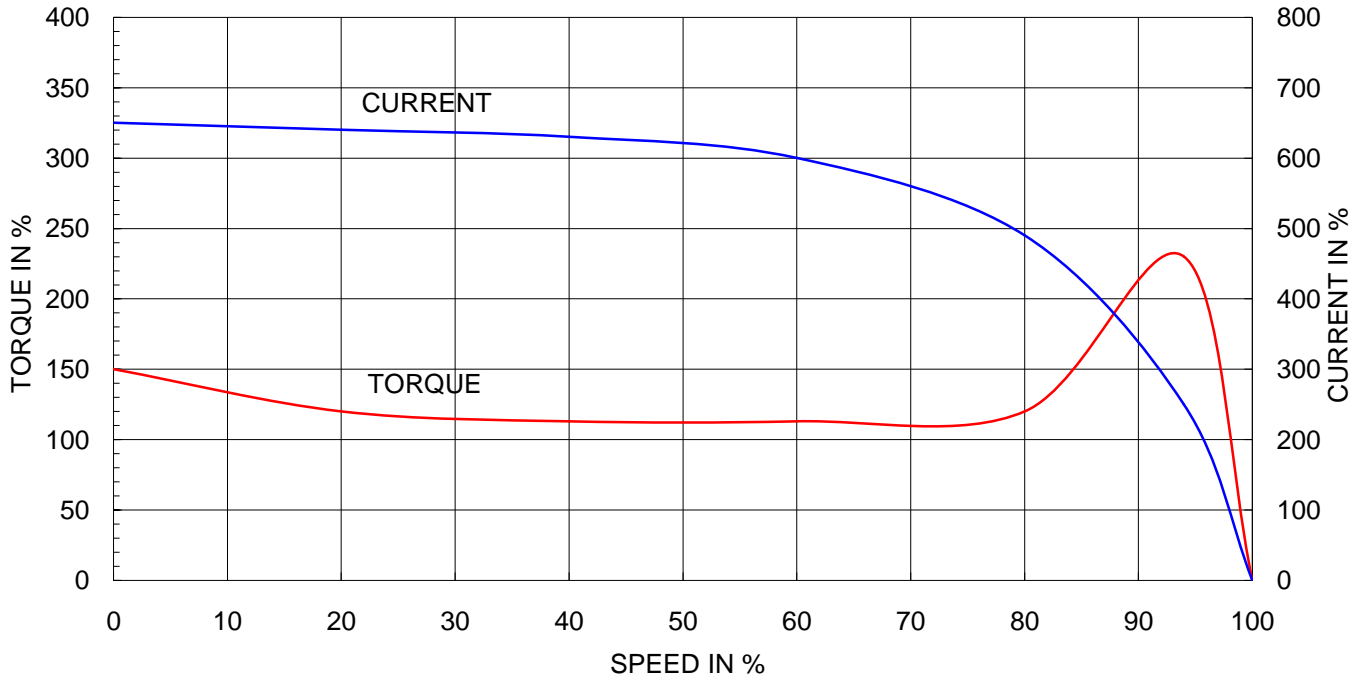

OUTPUT VS EFF., P.F & CURRENT CURVE

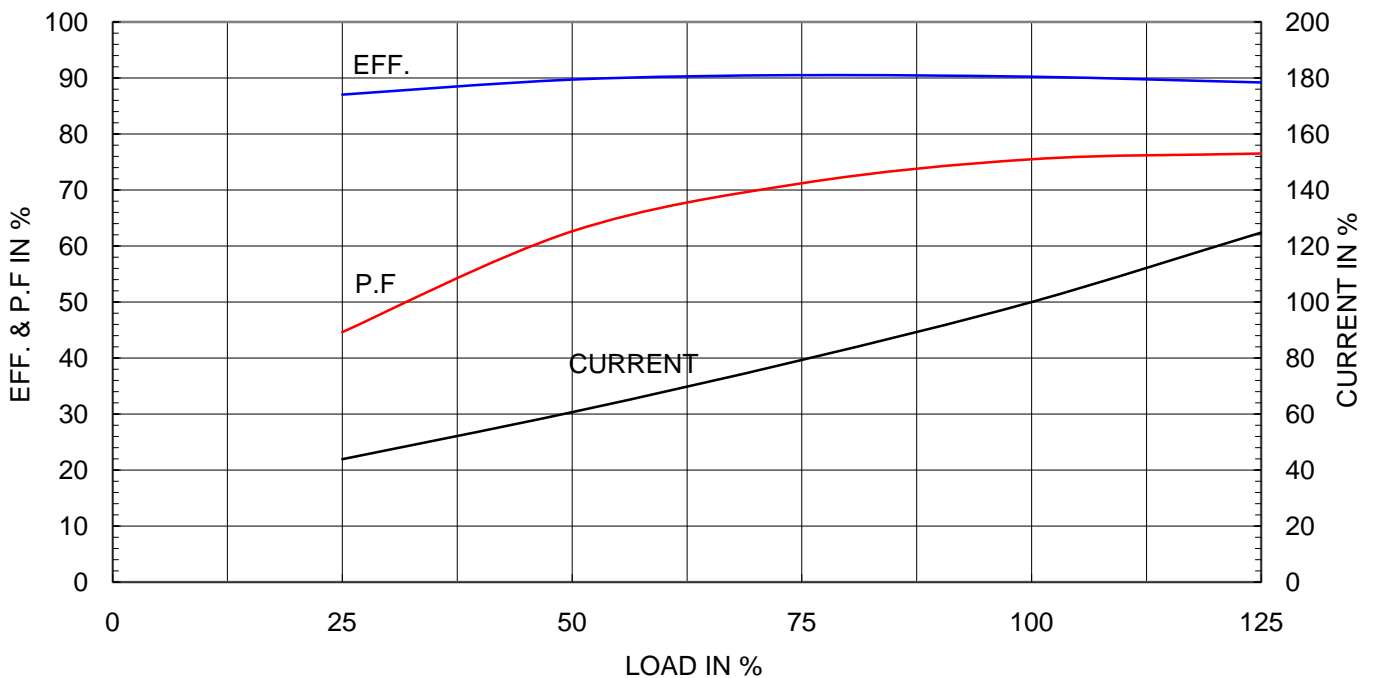



TEFC

THREE PHASE INDUCTION MOTOR

TYPE

HL, HLS

CAST IRON FRAME

Exd II

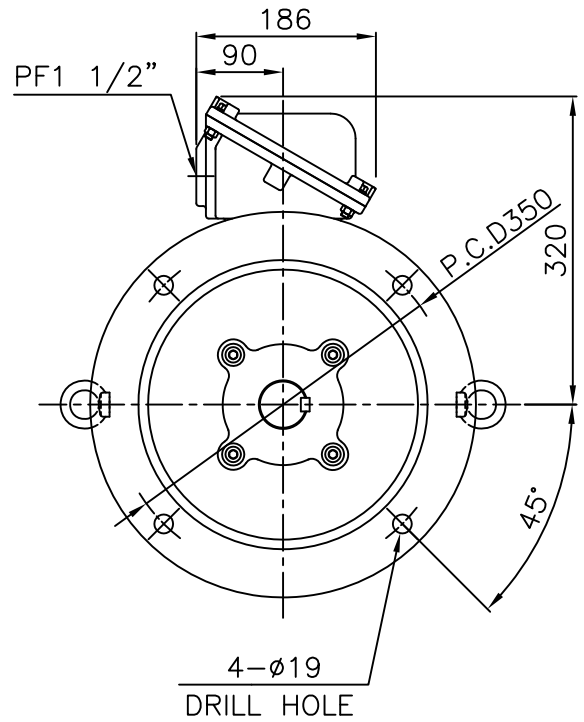
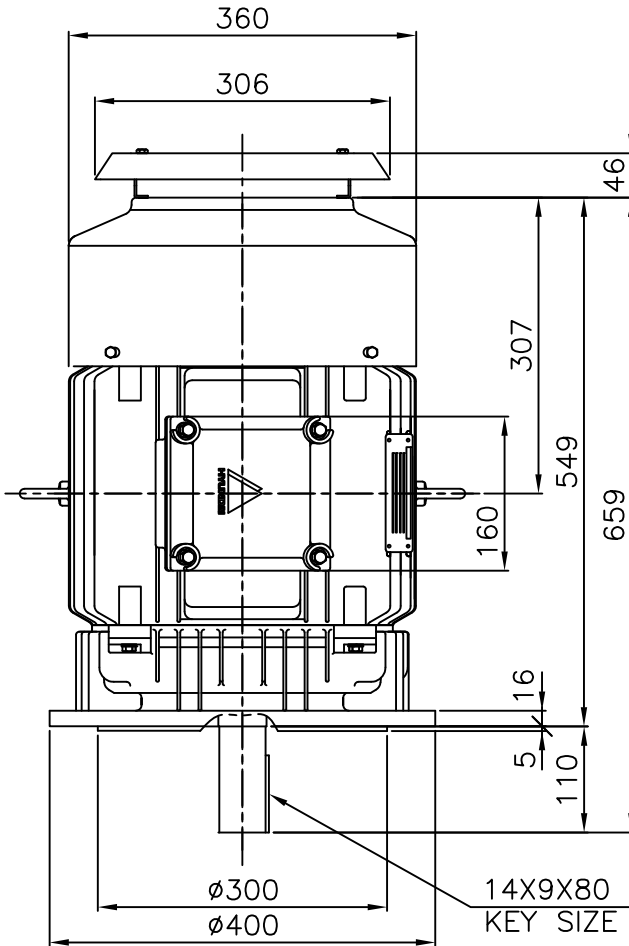

NOTE

1.TOLERANCE :

FLANGE HOLES	Ø19	+0.43	0
RABBET DIAMETER	Ø300	+0.016	-0.013
SHAFT DIAMETER	Ø48	+0.018	+0.002
KEYWAY WIDTH	14	0	-0.043
KEYWAY DEPTH	5.5	+0.2	0

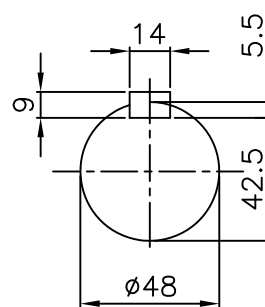

APPD BY	Y. S. KIM	UNIT	mm
CHKD BY	K. S. LEE	SCALE	1/8
CHKD BY	-----	PROJEC'N	3rd Angle
DSND BY	I. K. KIM	DATE	2008.10.22

SUBJECT	KS 180M	CAD PROJ \ FILE	XSDNKS\B2062AA07
TITLE	OUTLINE		

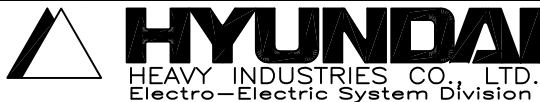

REF. NO	B2062AA07	Sheet No.	of
DWG NO	227B2062AA07	Revision No.	0

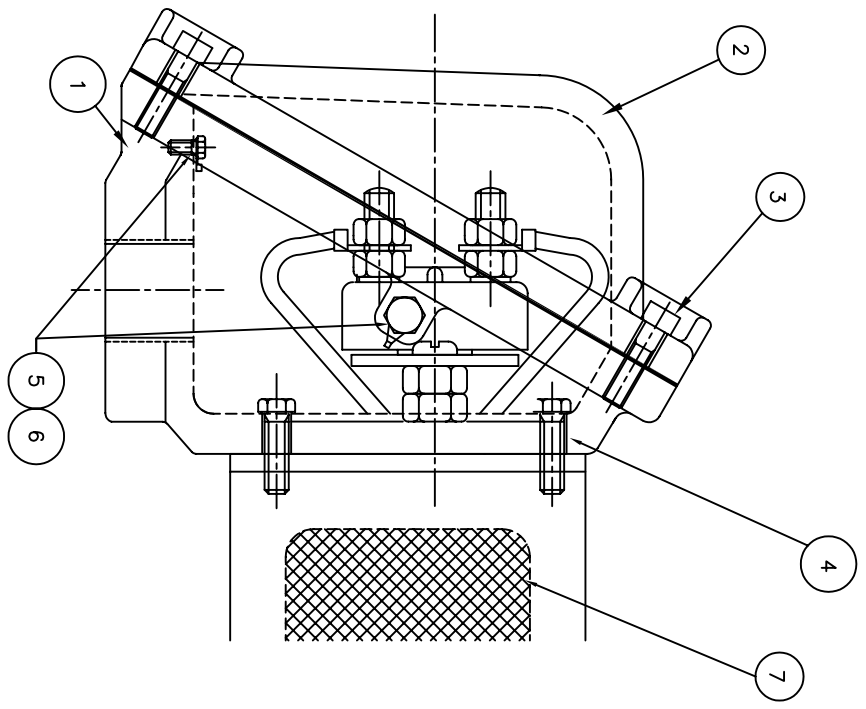
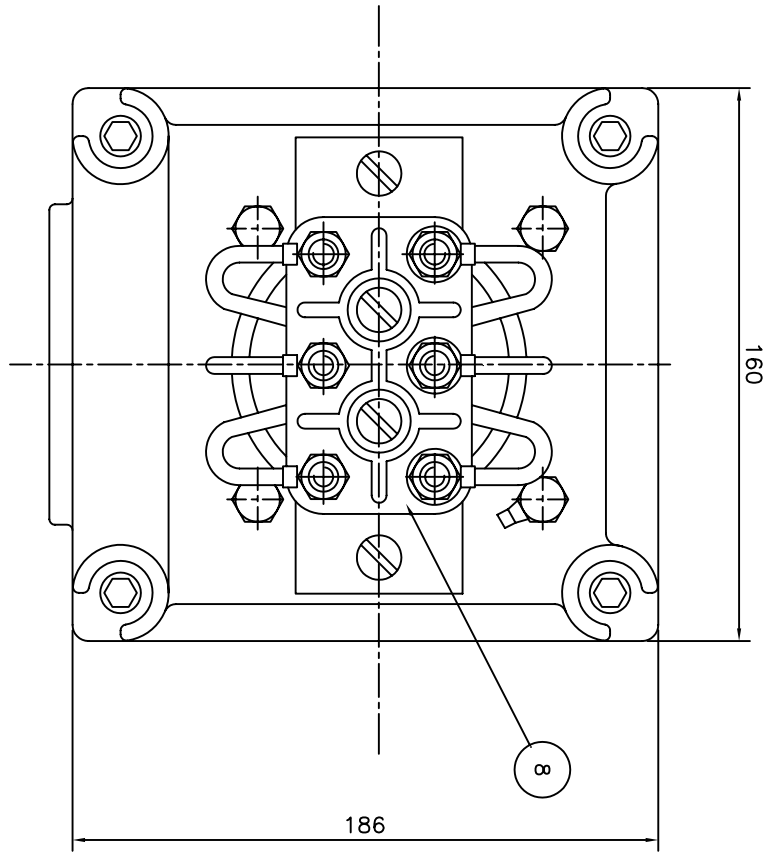

Q'TY	DESCRIPTION	MATERIAL	DIMENSION	WEIGHT	PART NO.	REMARK	NO.
1	TERMINAL BLOCK	D4C29C					8
1	SEALING COMPOUND	CU					7
2	GRD. TERMINAL LUG	S45C					6
2	GRD. BOLT	S45C					5
4	T/B + FRAME BOLT	S45C					4
4	T/B + COVER BOLT	S45C					3
1	TERMINAL BOX COVER	FC15					2
1	TERMINAL BOX ASSEMBLY	FC15					1

APPD BY	UNIT	MATERIAL	DIMENSION	WEIGHT	PART NO.	REMARK	NO.
CHKD BY	SCALE	N/S	SUBJECT	IEC 160/180FR d2G4		CAD PROJ \FILE XSMOUT\7B1468LB	
CHKD BY	PROJEC'N	3*48 (3rd Angle)	TITLE	MAIN TERMINAL BOX			
DSND BY	DATE	99.2.2	REF. NO	7B1470LB	Sheet No. of		
	DESIGNER	LEE E.J.	DWG NO	227B1470LB	Revision No.	0	

REV	DATE	CONTENTS	REVD BY	CHKD BY	CHKD BY	APPD BY
1						
2						
3						
4						



REF. NO 7B1470LB
DWG NO 227B1470LB
Revision No. 0