

Model No.or RFQ No.		Item No.		Rev. No. [0]	
Project Name		Project No.		Quantity sets	
GENERAL SPECIFICATION			PERFORMANCE DATA		
Frame Size	280LL		Rated Output	200 kW 268 HP	
Type	HS-200/2		Number of Poles	2	
Enclosure(Protection)	Totally Enclosed (IP55)		Rotor Type	Squirrel Cage	
Method of Cooling	IC411(FC)		Starting Method*	<input checked="" type="checkbox"/> D.O.L <input type="checkbox"/> Y- Δ	
Rated Frequency	60 Hz		Rated Voltage	440 V	380 V 220 V
Number of Phases	3		Current	Full Load	301.9 A 349.6 A 603.8 A
Insulation Class	<input checked="" type="checkbox"/> F <input type="checkbox"/> B <input type="checkbox"/> H			Locked-rotor**	630 % 630 % 630 %
Temp. Rise at full load (by resistance method)			Efficiency		
at 1.0 S.F 80 deg. C			50% Load 93.8 %		
Motor Location <input checked="" type="checkbox"/> Indoor <input type="checkbox"/> Outdoor			75% Load 94.9 %		
Altitude Less than 1000 meter			100% Load 95.0 %		
Relative Humidity Less than 80 %			Power Factor(p.u)		
Ambient Temp. 40 deg. C (Max.)			50% Load 0.912		
Duty Type Continuous (S1)			75% Load 0.915		
Service Factor 1.15			100% Load 0.915		
Mounting <input type="checkbox"/> B3 <input type="checkbox"/> B5 <input type="checkbox"/> V1 <input checked="" type="checkbox"/> B3/B5			Speed at Full Load 3570 r.p.m		
Bearing	Type	Anti-Friction		Torque	
	DE/N-DE	6314C3 / 6314C3		Full Load	54.6 kg·m
Lubricant		Grease(Gadus S2 V 100 2)		Locked-rotor**	150 %
External Thrust Not applicable			Breakdown** 230 %		
Coupling Method <input checked="" type="checkbox"/> Direct <input type="checkbox"/> V-Belt			Moment of Inertia (J)		
Shaft Extension <input checked="" type="checkbox"/> Single <input type="checkbox"/> Double			Load(Max.) 19.550 kg·m ²		
Terminal Box	Main	<input type="checkbox"/> Steel <input checked="" type="checkbox"/> Cast Iron		Motor 3.595 kg·m ²	
	Aux.	<input type="checkbox"/> Yes <input checked="" type="checkbox"/> No		Sound Pressure Level (No-load & mean value at 1m from motor)	
Location Refer to Outline Drawing			92 dB(A)		
Application			Vibration 2.2 mm/sec (r.m.s)		
Area classification Non-Hazardous			Permissible number of consecutive starts		
Type of Ex-Protection Not applicable			Cold 3 times		
Applicable Standard KS,IEC,NEMA MG1 Part30(Vpeak)			Hot 2 times		
			Paint	Munsell No.	4.0PB5.4/5.5(VL-451)
ACCESSORIES			SUBMITTAL DRAWING		
			Outline Dimension Drawing \ Motor Weight(Approx.)		
			B3		kg
			B5		kg
			V1		kg
			B3/B5	TJ8XCC50	1135 kg
Main T-Box Ass'y			3M-016882		
SPARE PARTS			REMARK		
			High Efficiency		
			*. For use on PWM VFD 10:1VT, 3:1CT@1.0S.F&F Temp. rise		
			Date	DSND	CHKD
			2010-05-28	R.G. KIM	O.J. KIM
				CHKD	APPD
				J.H. KIM	K.J. KANG

Note: Others not mentioned in this data sheet shall be in accordance with maker standard.
 Above technical data are only design values and shall be guaranteed with tolerance of applicable standard.
 Inspection and performance test shall be maker standard, if not mentioned.
 * In case of Inverter-Fed Motor, performance data is based on sine wave tests.
 ** Data is based on when the motor is supplied at rated voltage & frequency, and the data is expressed as a percentage of full-load value.

Type	:	HS
Full Load Torque	:	54.6 Kg.m
Motor moment of Inertia (J)	:	3.595 Kg.m ²
Load moment of Inertia (J)	:	19.550 Kg.m ²

200 kW	2 P	60 Hz	
Speed at Full Load :			
3570 RPM			
Rated Voltage	440V	380V	220V
Full Load Current	301.9A	349.6A	603.8A

SPEED VS TORQUE & CURRENT CURVE

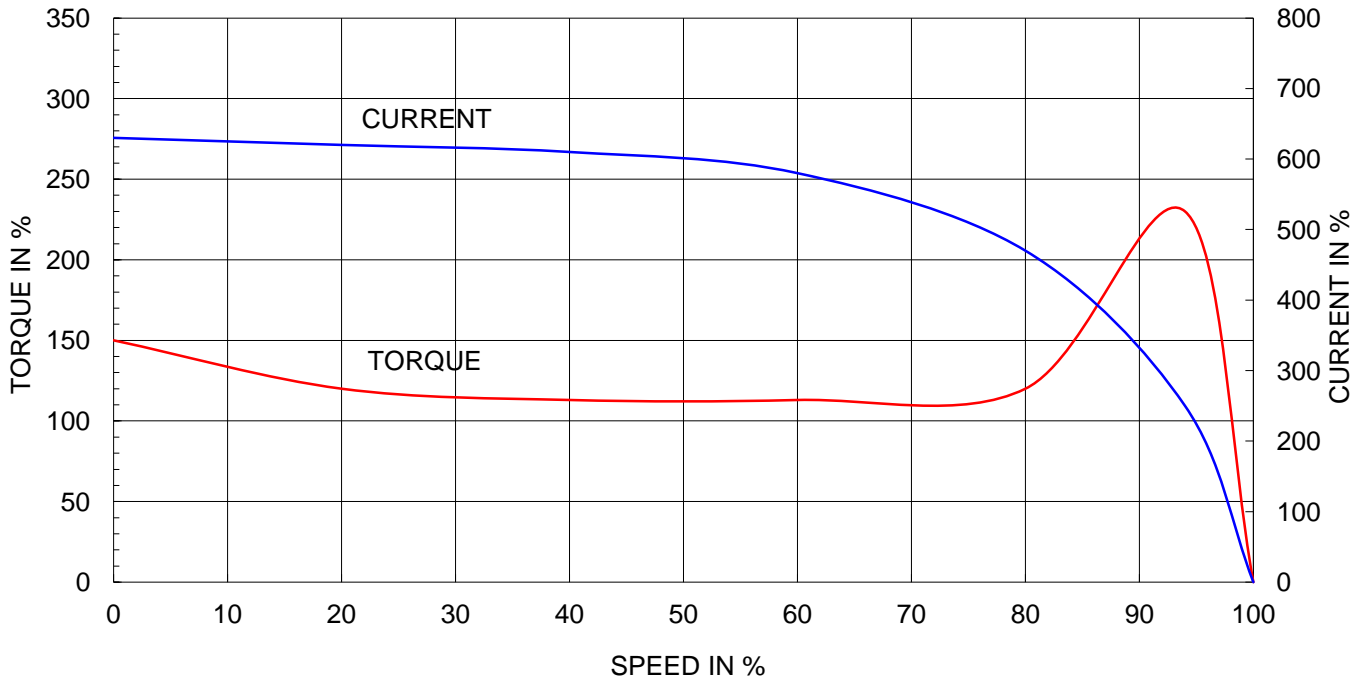

OUTPUT VS EFF., P.F & CURRENT CURVE

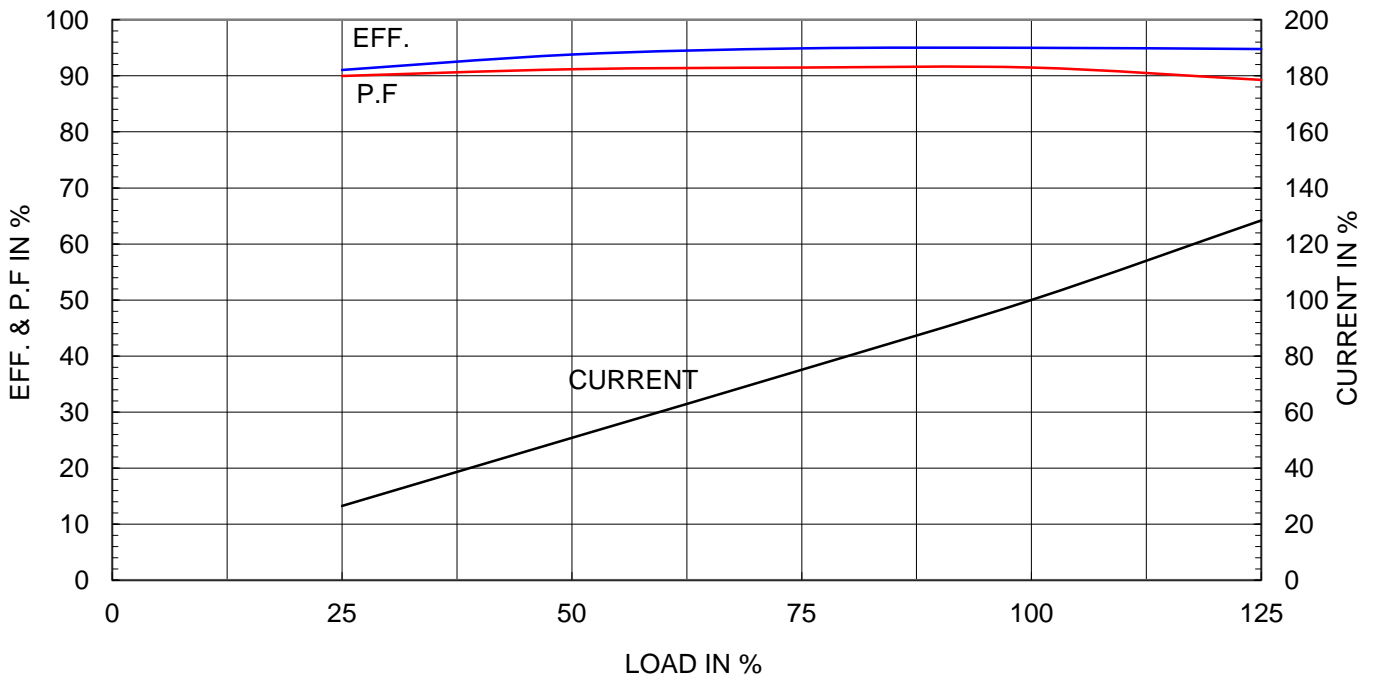

		<h1>TEFC</h1>		TYPE (1) TNB , TDB CAST IRON FRAME
		THREE PHASE INDUCTION MOTOR		

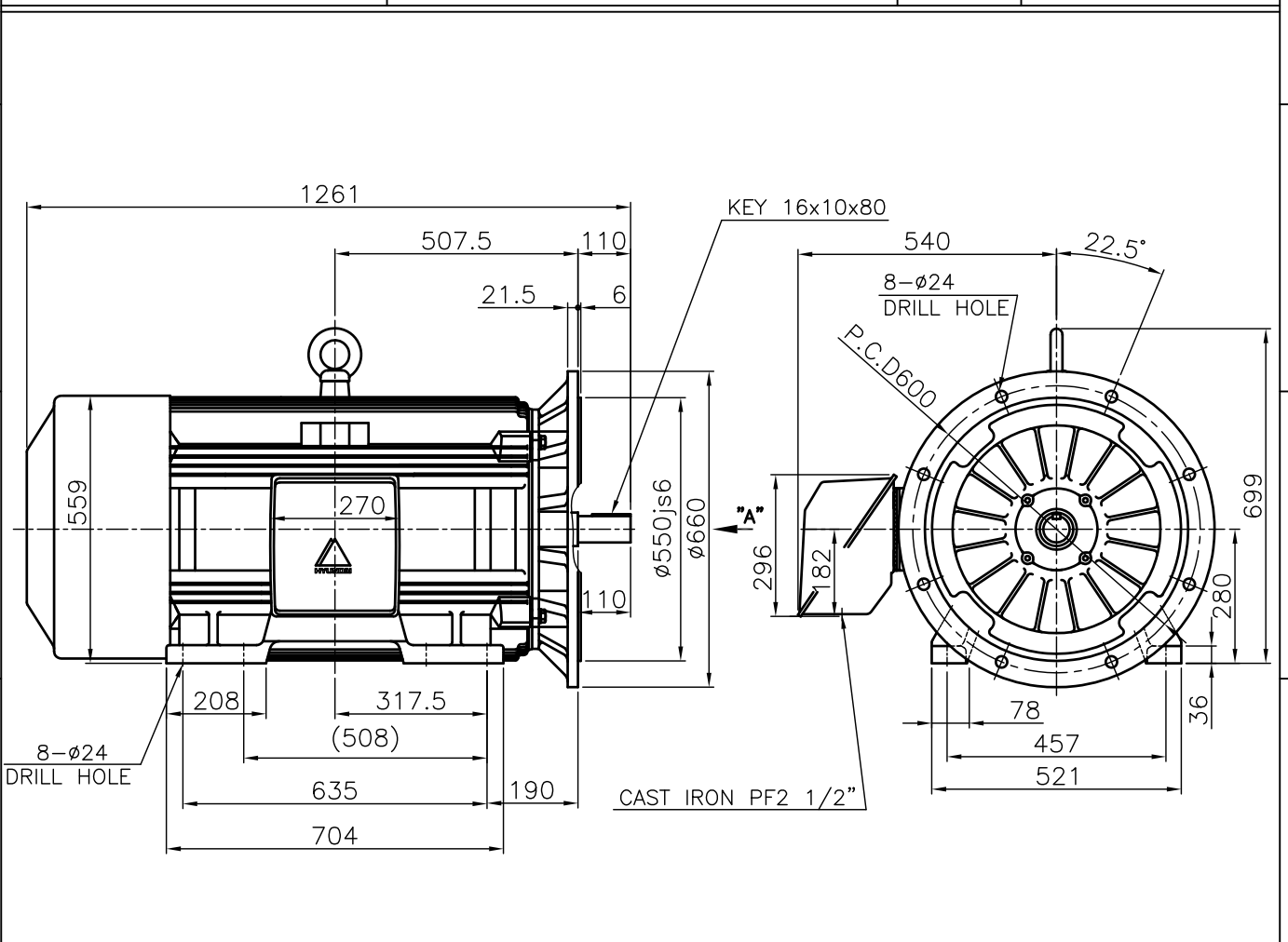

NOTE

1.TOLERANCE :

CENTER HEIGHT	280	$0_{-1.0}$
RABBET DIAMETER	ø550	± 0.022
SHAFT DIAMETER	ø55	$+0.030_{+0.011}$
KEYWAY WIDTH	16	$-0.018_{-0.061}$
KEYWAY DEPTH	6	$+0.2_0$

2.The type (1)-"TNB , TDB" is for HHI's standard products and it can be changed for customer's requirements or detail designing.

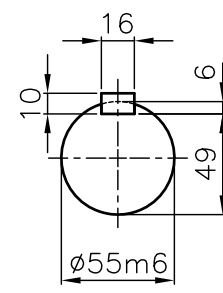

VIEW "A"
SCALE 4/1

				TEFC STANDARD	
APPD BY	KANG K.J.	MM	SUBJECT	KS Fr.280LL TEFC	CAD PROJ \ FILE
CHKD BY	KIM R.G.	SCALE	1/15	OUTLINE THREE-PHASE INDUCTION MOTOR	MMSTDMTR/TJ8XCC50
CHKD BY	LEE N.D.	PROJEC'N	3rd Angle		
DSND BY	KIM RYANG GYU	DATE	2007.03.23		
				REF. NO	L2-Series
				DWG NO	TJ8XCC50
				Sheet No.	of
				Revision No.	0

본 도면은 현대중공업(주) 재산이므로 허가없이
복사할 수 없음 (도면제출 시 유의하시기 바랍니다.)

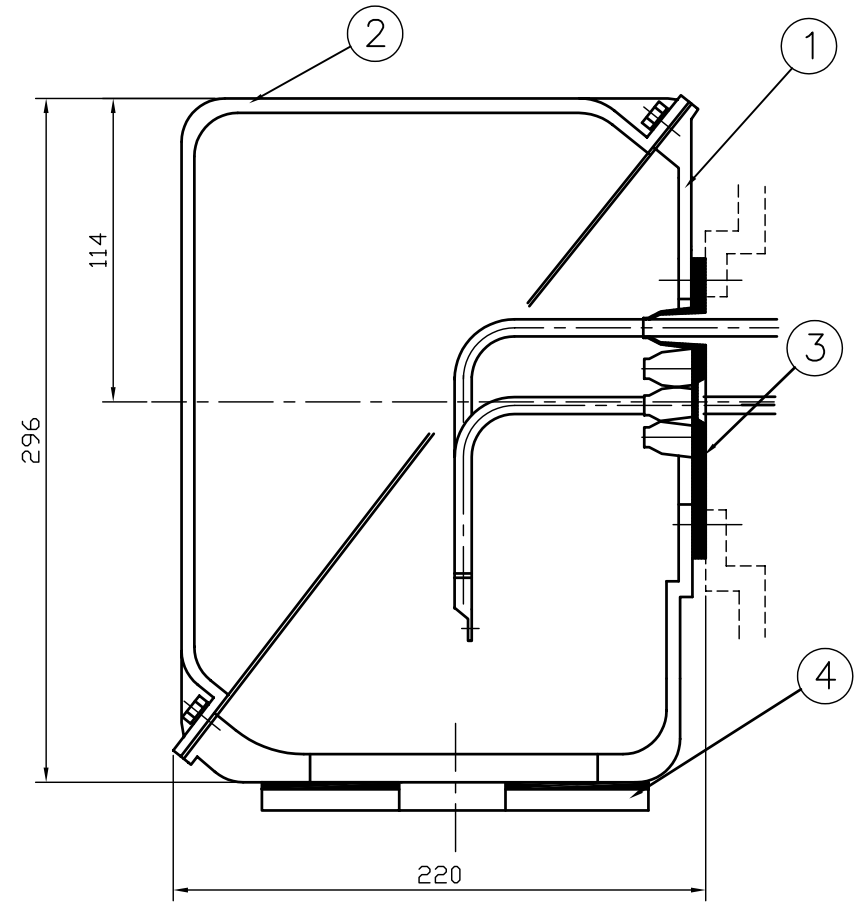
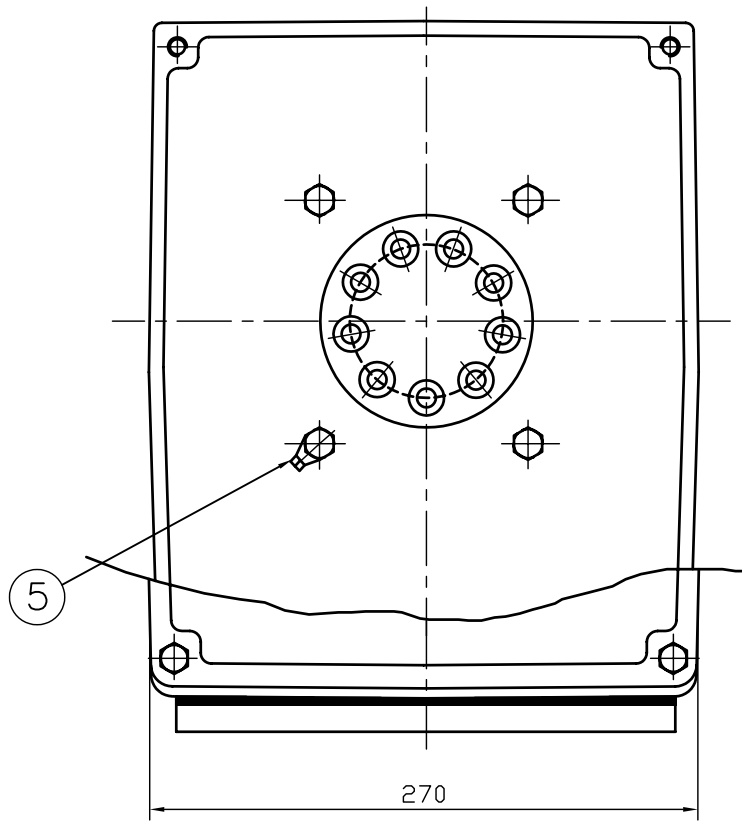

1	EARTH TERMINAL LUG						5
1	CABLE ENTRY PLATE						4
1	GASKET	NBR					3
1	TERMINAL BOX COVER	CAST IRON					2
1	TERMINAL BOX BODY	CAST IRON					1

Q'TY	DESCRIPTION	MATERIAL	DIMENSION	WEIGHT	PART NO.	REMARK	NO.
APPD BY	김진오	UNIT	MM	SUBJECT	HLA6 - 250,280Fr. CAD PROJ FILE		
Q.P CHK	주영걸	SCALE	NONE	TITLE	(CAST IRON)		
CHKD BY	권오철	PROJEC'N	3각법(3rd Angle)	TERMINAL BOX ASS'Y			
DSND BY	김헌태	DATE	92.06.05	REF. NO		Sheet No. of	
				DWG NO	3M-016882	Revision No.	

REV	DATE	CONTENTS	REVD BY	CHKD BY	Q.P CHK	APPD BY
1						