

Model No. or RFQ No.		Item No.		Rev. No. [ 0 ]		
Project Name		Project No.		Quantity sets		
GENERAL SPECIFICATION			PERFORMANCE DATA			
Frame Size	280M		Rated Output	132 kW 175 HP		
Type	HS-132/4		Number of Poles	4		
Enclosure(Protection)	Totally Enclosed ( IP55 )		Rotor Type	Squirrel Cage		
Method of Cooling	IC411(FC)		Starting Method*	<input checked="" type="checkbox"/> D.O.L <input type="checkbox"/> Y- Δ		
Rated Frequency	60 Hz		Rated Voltage	440 V	380 V 220 V	
Number of Phases	3		Current	Full Load	207.2 A 239.9 A 414.4 A	
Insulation Class	<input checked="" type="checkbox"/> F <input type="checkbox"/> B <input type="checkbox"/> H			Locked-rotor**	670 %    670 %    670 %	
Temp. Rise at full load (by resistance method)			Efficiency			
at 1.0 S.F    80 deg. C			50% Load    94.4 %			
Motor Location <input checked="" type="checkbox"/> Indoor <input type="checkbox"/> Outdoor			75% Load    95.0 %			
Altitude    Less than 1000 meter			100% Load    95.0 %			
Relative Humidity    Less than 80 %			Power Factor(p.u)			
Ambient Temp.    40 deg. C (Max.)			50% Load    0.848			
Duty Type    Continuous ( S1 )			75% Load    0.878			
Service Factor    1.15			100% Load    0.880			
Mounting <input type="checkbox"/> B3 <input type="checkbox"/> B5 <input type="checkbox"/> V1 <input checked="" type="checkbox"/> B3/B5			Speed at Full Load    1785 r.p.m			
Bearing	Type	Anti-Friction		Torque		
	DE/N-DE	6318C3 / 6316C3		Full Load	72.0 kg·m	
	Lubricant	Grease(Gadus S2 V 100 2)		Locked-rotor**	180 %	
External Thrust    Not applicable			Breakdown**    230 %			
Coupling Method <input checked="" type="checkbox"/> Direct <input type="checkbox"/> V-Belt			Moment of Inertia (J)			
Shaft Extension <input checked="" type="checkbox"/> Single <input type="checkbox"/> Double			Load(Max.)    111.825 kg·m <sup>2</sup>			
Terminal Box	Main	<input type="checkbox"/> Steel <input checked="" type="checkbox"/> Cast Iron		Motor    3.415 kg·m <sup>2</sup>		
	Aux.	<input type="checkbox"/> Yes <input checked="" type="checkbox"/> No		Sound Pressure Level (No-load & mean value at 1m from motor)		
	Location	Refer to Outline Drawing		85 dB(A)		
Application			Vibration    2.2 mm/sec (r.m.s)			
Area classification    Non-Hazardous			Permissible number of consecutive starts			
Type of Ex-Protection    Not applicable			Cold    3 times			
Applicable Standard    KS,IEC,NEMA MG1 Part30(Vpeak)			Hot    2 times			
			Paint	Munsell No.	4.0PB5.4/5.5(VL-451)	
ACCESSORIES			SUBMITTAL DRAWING			
			Outline Dimension Drawing \ Motor Weight(Approx.)			
			B3			kg
			B5			kg
			V1			kg
			B3/B5		TJ8MCP51	775
Main T-Box Ass'y			3M-016882			
SPARE PARTS			REMARK			
			<b>High Efficiency</b> *. For use on PWM VFD 10:1VT, 3:1CT@1.0S.F&F Temp. rise			
			Date	DSND	CHKD	
			2010-05-28	R.G. KIM	O.J. KIM	
				CHKD	APPD	
				J.H. KIM	K.J. KANG	

Note: Others not mentioned in this data sheet shall be in accordance with maker standard.  
 Above technical data are only design values and shall be guaranteed with tolerance of applicable standard.  
 Inspection and performance test shall be maker standard, if not mentioned.  
 \* In case of Inverter-Fed Motor, performance data is based on sine wave tests.  
 \*\* Data is based on when the motor is supplied at rated voltage & frequency, and the data is expressed as a percentage of full-load value.

Type	:	HS
Full Load Torque	:	72.0 Kg.m
Motor moment of Inertia (J)	:	3.415 Kg.m <sup>2</sup>
Load moment of Inertia (J)	:	111.825 Kg.m <sup>2</sup>

132 kW	4 P	60 Hz
Speed at Full Load :		1785 RPM
Rated Voltage	440V	380V
Full Load Current	207.2A	239.9A
		414.4A

SPEED VS TORQUE & CURRENT CURVE

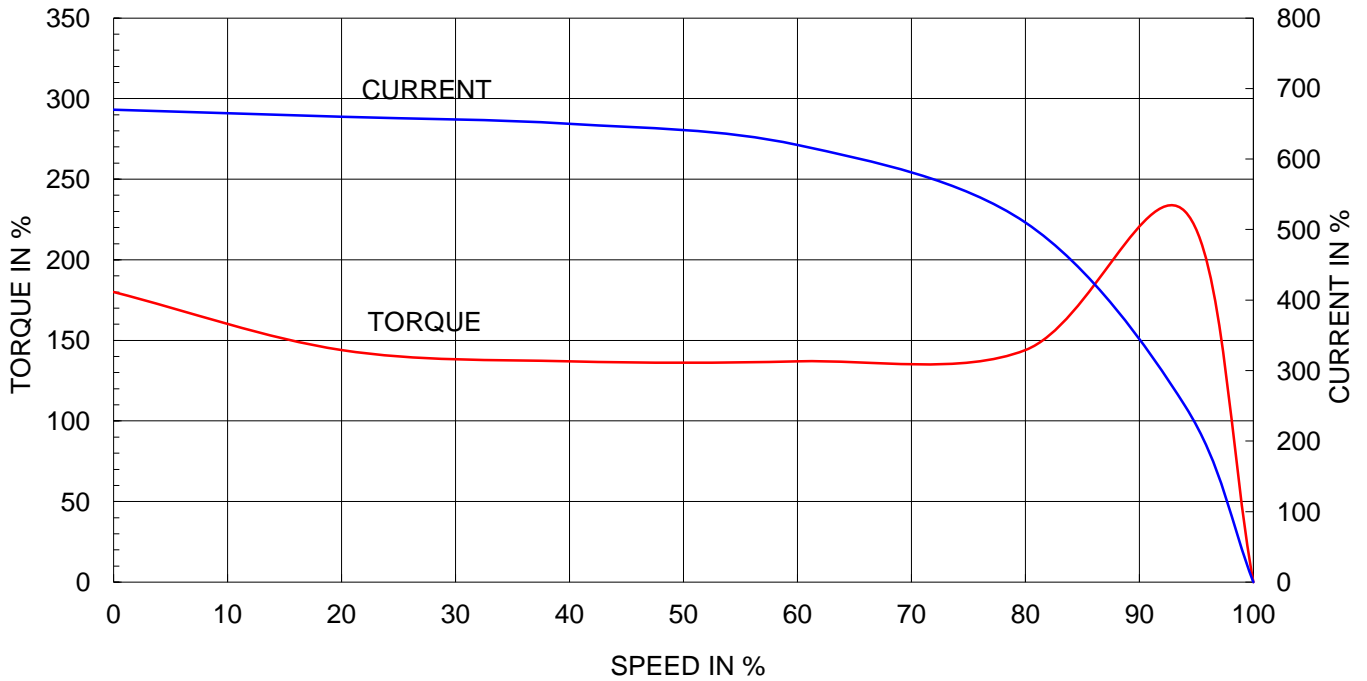

OUTPUT VS EFF., P.F & CURRENT CURVE

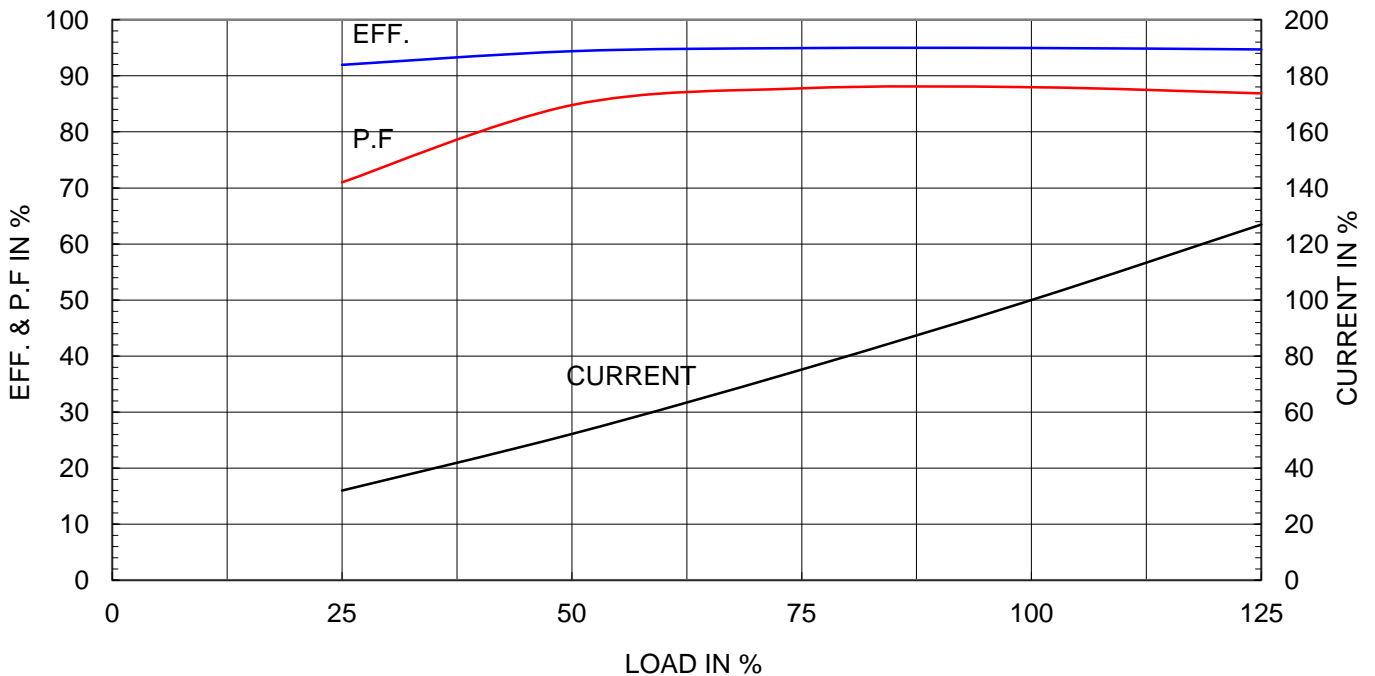



# TEFC

## THREE PHASE INDUCTION MOTOR

**TYPE**

(1)  
TNB , TDB  
CAST IRON FRAME

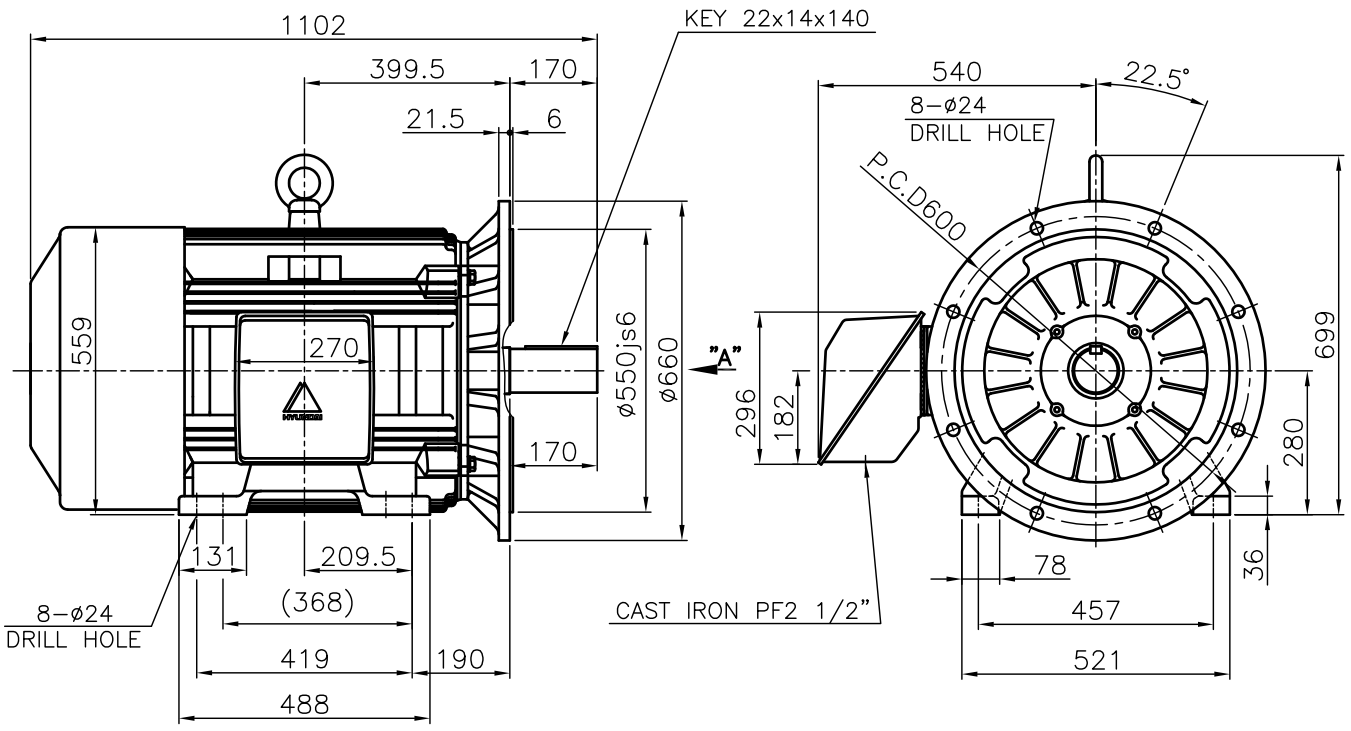

**NOTE**

1.TOLERANCE :

CENTER HEIGHT	280	$\begin{smallmatrix} 0 \\ -1.0 \end{smallmatrix}$
RABBET DIAMETER	$\phi 550 \pm 0.022$	
SHAFT DIAMETER	$\phi 85$	$\begin{smallmatrix} +0.035 \\ +0.013 \end{smallmatrix}$
KEYWAY WIDTH	22	$\begin{smallmatrix} -0.022 \\ -0.074 \end{smallmatrix}$
KEYWAY DEPTH	9	$\begin{smallmatrix} +0.2 \\ 0 \end{smallmatrix}$

2.The type (1)-"TNB , TDB" is for HHI's standard products and it can be changed for customer's requirements or detail designing.

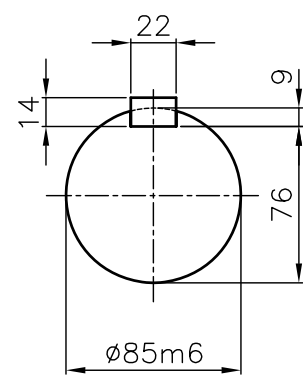

**VIEW "A"**  
SCALE 4/1

TEFC STANDARD
CAD PROJ \ FILE
MMSTDMTR/TJ8MCP51

APPD BY	KANG K.J.	UNIT	MM
CHKD BY	KIM O.J.	SCALE	1/15
CHKD BY	LEE N.D.	PROJEC'N	3rd Angle
DSND BY	KIM RYANG GYU	DATE	2007.03.23

SUBJECT	KS Fr.280M TEFC
TITLE	<b>OUTLINE</b> THREE-PHASE INDUCTION MOTOR



REF. NO	L2-Series	Sheet No. of
DWG NO	TJ8MCP51	Revision No. 0

본 도면은 현대중공업(주) 재산이므로 허가없이  
복사할 수 없음 (도면제출 시 유의하시기 바랍니다.)

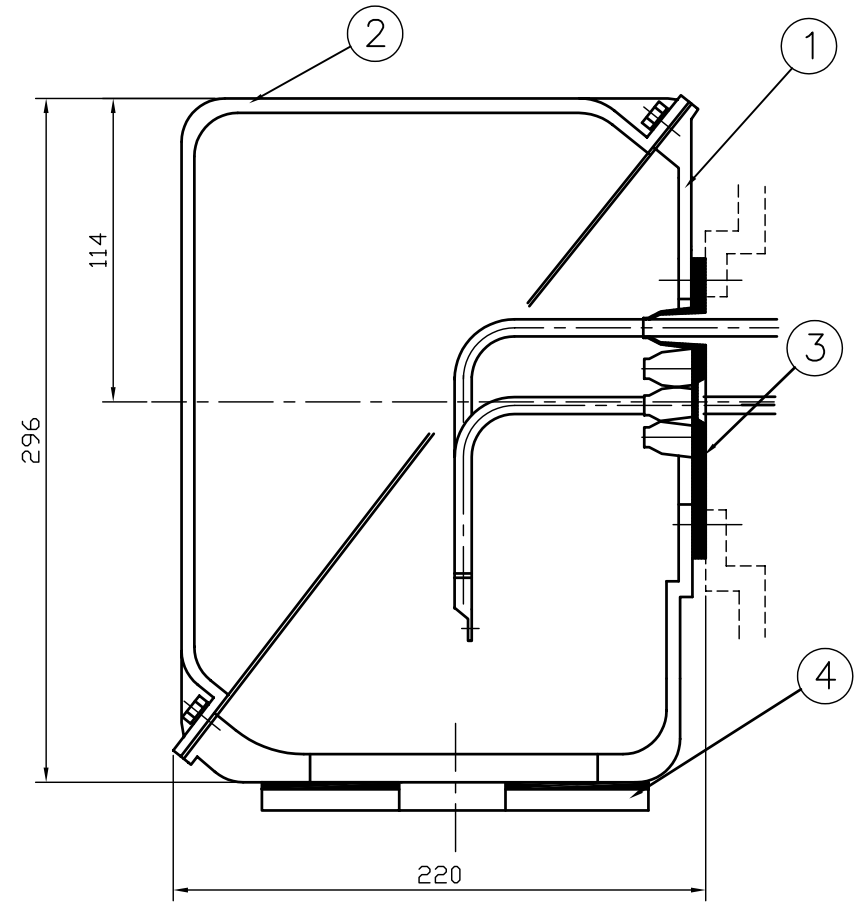
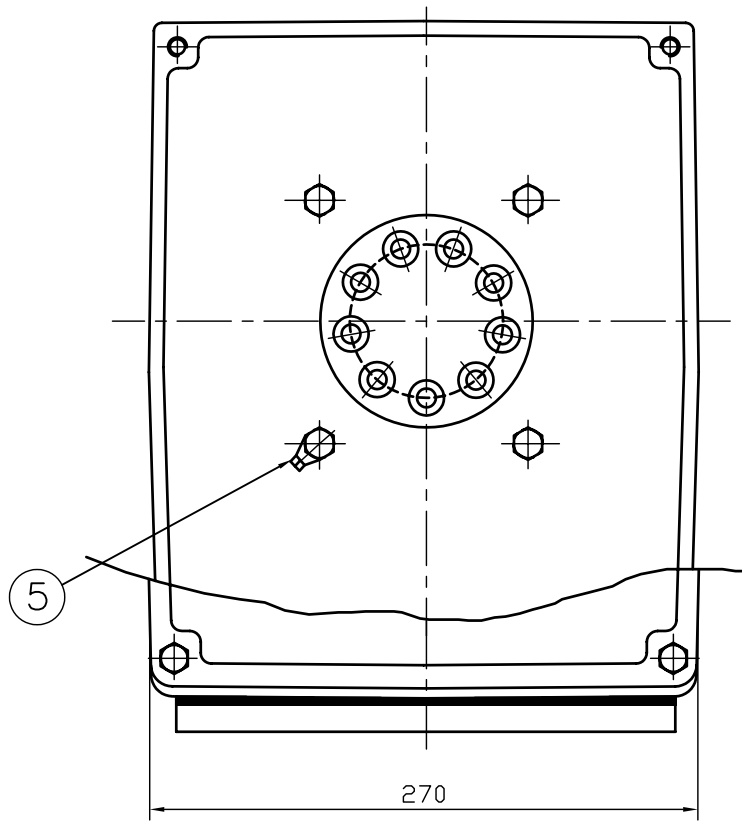

1	EARTH TERMINAL LUG						5
1	CABLE ENTRY PLATE						4
1	GASKET	NBR					3
1	TERMINAL BOX COVER	CAST IRON					2
1	TERMINAL BOX BODY	CAST IRON					1

Q'TY	DESCRIPTION	MATERIAL	DIMENSION	WEIGHT	PART NO.	REMARK	NO.
APPD BY	김진오	UNIT	MM	SUBJECT	HLA6 - 250,280Fr. CAD PROJ FILE		
Q.P CHK	주영걸	SCALE	NONE	TITLE	(CAST IRON)		
CHKD BY	권오철	PROJEC'N	3각법(3rd Angle)	TERMINAL BOX ASS'Y			
DSND BY	김헌태	DATE	92.06.05	REF. NO		Sheet No. of	
				DWG NO	3M-016882	Revision No.	

REV	DATE	CONTENTS	REVD BY	CHKD BY	Q.P CHK	APPD BY
1						